



Service Manual

Greensmaster® 1000/1600

Preface

The purpose of this publication is to provide the service technician with information for troubleshooting, testing, and repairing assemblies and components on the Greensmaster 1000/1600.

REFER TO THE OPERATOR'S MANUAL FOR OPERATING, MAINTENANCE, AND ADJUSTMENT INSTRUCTIONS. Space is provided in Chapter 2 of this book to insert the Operator's Manual and Parts Catalogs for your machine. Replacement Operator's Manuals are available by sending complete Model and Serial Number to:

The Toro Company
8111 Lyndale Avenue South
Minneapolis, MN 55420-1196

The Toro Company reserves the right to change product specifications or this publication without notice.



This safety symbol means **DANGER, WARNING, or CAUTION, PERSONAL SAFETY INSTRUCTION**. When you see this symbol, carefully read the instructions that follow. Failure to obey the instructions may result in personal injury.

NOTE: A NOTE will give general information about the correct operation, maintenance, service, testing, or repair of the machine.

IMPORTANT: The **IMPORTANT** notice will give important instructions which must be followed to prevent damage to systems or components on the machine.



Table Of Contents

Chapter 1 – Safety

Safety Instructions	1 – 1
Safety and Instruction Decals	1 – 4

Chapter 2 – Product Records and Manuals

Product Records	2 – 1
Equivalents and Conversions	2 – 2
Torque Specifications	2 – 3
Operation and Service History Report	2 – 5

Chapter 3 – Engine

Introduction	3 – 2
Specifications	3 – 3
General Information	3 – 4
Adjustments	3 – 6
Services and Repairs	3 – 8
Kawasaki FE161 & FE170 Service Manual and Kawasaki FE120 Service Manual Supplement	

Chapter 4 – Traction and Reel Drive System

Specifications	4 – 2
Special Tools	4 – 3
Adjustments	4 – 4
Service and Repairs	4 – 8

Chapter 5 – Electrical System

Wiring Schematics	5 – 2
Special Tools	5 – 6
Trouble Shooting	5 – 7
Component Testing	5 – 8
Service and Repairs	5 – 13

Chapter 6 – Controls, Wheels and Accessories

Specifications	6 – 2
Adjustments	6 – 3
Service and Repairs	6 – 4

Chapter 7 – Cutting Unit

Introduction	7 – 2
Specifications	7 – 3
General Information	7 – 4
Special Tools	7 – 5
Troubleshooting	7 – 7
Adjustments	7 – 9
Service and Repairs	7 – 13

Chapter 8 – Grooming Reel Kit (See Note Below)

Specifications	8 – 2
General Information	8 – 3
Troubleshooting	8 – 4
Adjustments	8 – 6
Service and Repairs	8 – 8

Note: This chapter covers the Model 04125 Grooming Reel Kit only (for the Greensmaster 1000).

Safety

Product Records
and Manuals

Engine

Traction and Reel
Drive System

Electrical
System

Wheels and
Accessories

Cutting Unit

Grooming Reel
Kit



Table of Contents

SAFETY INSTRUCTIONS	1	Maintenance and Service	2
Before Operating	1	SAFETY AND INSTRUCTION DECALS	3
While Operating	2		

Safety Instructions

The GREENSMaster 1000 was tested and certified by TORO for compliance with the B71.4–1984 specifications of the American National Standards Institute. Although hazard control and accident prevention partially are dependent upon the design and configuration of the machine, these factors are also dependent upon the awareness, concern, and proper training of the personnel involved in the operation, transport, maintenance, and storage of the machine. Improper use or maintenance of the machine can result in injury or death.

To reduce the potential for injury or death, comply with the following safety instructions.



Before Operating

1. Operate the machine only after reading and understanding the contents of this manual. A replacement manual is available by sending the complete model and serial number to:

The Toro Company
8111 Lyndale Avenue South
Minneapolis, Minnesota 55420–1196
2. Never allow children to operate the machine, nor allow adults to operate it without proper instructions.
3. Become familiar with the controls, and know how to stop the engine quickly.
4. Keep all shields, safety devices, and decals in place. If a shield, safety device, or decal is malfunctioning, illegible, or damaged, repair or replace it before operating the machine.
5. Always wear substantial shoes. Do not operate machine while wearing sandals, tennis shoes or sneakers. Do not wear loose fitting clothing which could get caught in moving parts and cause personal injury.
6. Wearing safety glasses, safety shoes, long pants and a helmet is advisable and required by some local safety and insurance regulations.
7. Assure work area is clear of objects which might be picked up and thrown by the reel.
8. Keep everyone, especially children and pets away from the areas of operation.
9. Gasoline is highly flammable; handle it carefully.
 - A. Use an approved gasoline container.
 - B. Do not remove cap from fuel tank when engine is hot or running.
 - C. Do not smoke while handling gasoline.
 - D. Fill fuel tank outdoors and no higher than to the bottom of filter screen. Do not overfill.
 - E. Wipe up any spilled gasoline.
 - F. Fuel may leak from filler neck when mower is tilted for servicing if tank is over filled.

10. Check the safety interlock switch daily for proper operation; see Component Testing in Chapter 5 – Electrical System. Replace malfunctioning switches before

operating machine. (After every two years, replace the interlock switch in the safety system, whether it is working properly or not.)

While Operating

11. Do not run the engine in a confined area without adequate ventilation. Exhaust fumes are hazardous and could be deadly.

12. Always stand behind the handles when starting and operating the machine.

13. To start and stop the engine:

- A. Open fuel shut-off valve.
- B. Verify that the traction drive lever on handle is in NEUTRAL position and reel drive lever on mower is DISENGAGED.
- C. Move on/off switch to ON position, set choke to full choke position (cold start) and throttle to half throttle.
- D. Pull starter cord to start engine.
- E. Move throttle to SLOW and on/off switch to OFF position to stop engine.

14. To transport mower from one area to another:

- A. Install transport wheels.
- B. Disengage reel drive lever.
- C. Start engine.
- D. Press down on handle to raise front of mower and engage traction drive.

15. Before beginning mowing operation:

- A. Stop engine.
- B. Disengage traction drive.
- C. Remove transport wheels.
- D. Engage reel drive lever.

16. Before emptying basket of clippings, disengage traction drive, reduce engine speed and move on/off switch to off position.

17. Do not touch engine, muffler or exhaust pipe while engine is running or soon after it has stopped because these areas are hot enough to cause burns.

18. If the cutting unit strikes a solid object or vibrates abnormally, stop immediately, turn engine off, wait for all motion to stop and inspect for damage. A damaged reel or bedknife must be repaired or replaced before operation is commenced.

19. Whenever machine is left unattended, be sure engine is stopped and cutting unit reel is not spinning. Close fuel shut-off valve if machine is not to be used for an extended period of time.

Maintenance and Service

20. Before servicing or making adjustments to the machine, stop the engine and pull the spark plug wire off spark plug to prevent accidental starting of the engine.

21. To make sure entire machine is in good condition, keep all nuts, bolts, screws and belts properly tightened.

22. If major repairs are ever needed or assistance is required, contact an Authorized TORO Distributor.

23. To reduce potential fire hazard, keep the engine area free of excessive grease, grass, leaves and accumulation of dirt.

24. If the engine must be running to perform a maintenance adjustment, keep hands, feet, clothing, and any parts of the body away from the cutting unit and any moving parts. Keep everyone away.

25. Do not overspeed the engine by changing governor settings. Maximum engine speed is 3600 rpm. To assure safety and accuracy, have an Authorized Toro Distributor check maximum engine speed with a tachometer.

26. Engine must be shut off before checking oil or adding oil to the crankcase.

27. To be sure of optimum performance and safety, always purchase genuine TORO replacement parts and accessories. Replacement parts and accessories made by other manufacturers could be dangerous. Such use could void the product warranty of The Toro Company.

Safety and Instruction Decals

The following safety and instruction decals are affixed to the traction unit. If any decal becomes illegible or damaged, install a new decal. Part numbers are listed below

and in your Parts Catalog. Order replacements from your Authorized Toro Distributor.

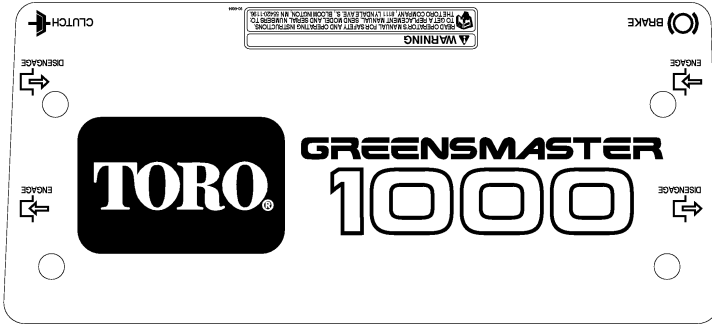

On Control Panel
Part No. 93-6084

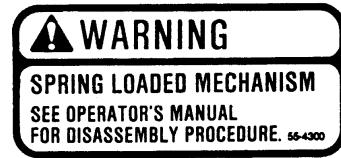

On Front Frame Tube
Part No. 55-4300

QUICK REFERENCE CHART

CHECK/SERVICE

1. ENGINE OIL LEVEL
2. FUEL - GAS ONLY
3. AIR CLEANER
4. TIRE PRESSURE (15 PSI.)
5. GREASE POINTS (13)

FLUID SPECIFICATIONS
*SEE OPERATOR'S MANUAL FOR INITIAL CHANGES.

	TYPE < 50 F	TYPE 50 F-95 F	TYPE > 95 F	CAPACITY	*CHANGE INTERVALS
ENGINE OIL	SAE 10W 30 MS-SG	SAE 30 MS-SC	SAE 40 MS-SC	1.0 Pt. (500cc)	50 HOURS
FUEL	UNLEADED GASOLINE				

93-6098

On Grass Shield
Part No. 93-6098

⚠ DANGER

FUEL IS FLAMMABLE AND COULD CAUSE INJURY IF IGNITED.
DO NOT FILL FUEL TANK WITH ENGINE RUNNING, ENGINE HOT OR WHEN IN AN ENCLOSED AREA. DO NOT SMOKE WHILE FILLING TANK.

FILL TANK NO HIGHER THAN TO BOTTOM OF FILLER NECK. DO NOT OVERFILL. WIPE UP SPILLED FUEL BEFORE STARTING ENGINE. FUEL MAY LEAK FROM FILLER NECK WHEN MOWER IS TILTED FOR SERVICING.

⚠ DANGER

DO NOT OPERATE THIS UNIT UNLESS ALL SHIELDS ARE FIRMLY SECURED. 88-7620

On Fuel Tank
Part No. 88-7620

⚠ WARNING

SHIELD MISSING DO NOT USE
88-8950

Inside Belt Covers (3)
Part No. 88-8950

GAS UNLEADED

On Fuel Tank
Part No. 53-4420

⚠ DANGER

NEVER PLACE HANDS OR FEET IN REEL AREA WHILE ENGINE IS RUNNING.

On Grass Shield
Part No. 62-5070



On Control Panel
Part No. 93-6085

⚠ WARNING

HOT

On Fuel Tank
Part No. 63-8440

⚠ DANGER

DO NOT OPERATE THIS UNIT UNLESS ALL SHIELDS ARE FIRMLY SECURED.

Inside Belt Cover
Part No. 675360

REEL DRIVE ENGAGEMENT

ENGAGE

DISENGAGE

On Belt Cover
Part No. 65-7660



On Control Panel
Part No. 93-9012



Product Records and Manuals

Table of Contents

PRODUCT RECORDS	1	TORQUE SPECIFICATIONS	3
EQUIVALENTS AND CONVERSIONS	2	Capscrew Markings and Torque Values – U.S. . .	3
Decimal and Millimeter Equivalents	2	Capscrew Markings and Torque Values – Metric	3
U.S. to Metric Conversions	2	OPERATION AND SERVICE HISTORY REPORT .	5

Product Records

Record information about your Greensmaster 1000/1600 on the OPERATION AND SERVICE HISTORY REPORT form. Use this information when referring to your machine.

Insert Operator’s Manuals and Parts Catalogs for your Greensmaster 1000/1600 at the end of this section.

Product Records
and Manuals

Equivalents and Conversions

Decimal and Millimeter Equivalents

Fractions	Decimals	mm	Fractions	Decimals	mm		
	1/64	0.015625	— 0.397	33/64	0.515625	— 13.097	
1/32	—	0.03125	— 0.794	17/32	—	0.53125	— 13.494
	3/64	0.046875	— 1.191	35/64	—	0.546875	— 13.891
1/16	—	0.0625	— 1.588	9/16	—	0.5625	— 14.288
	5/64	0.078125	— 1.984	37/64	—	0.578125	— 14.684
3/32	—	0.9375	— 2.381	19/32	—	0.59375	— 15.081
	7/64	0.109275	— 2.778	39/64	—	0.609375	— 15.478
1/8	—	0.1250	— 3.175	5/8	—	0.6250	— 15.875
	9/64	0.140625	— 3.572	41/64	—	0.640625	— 16.272
5/32	—	0.15625	— 3.969	21/32	—	0.65625	— 16.669
	11/64	0.171875	— 4.366	43/64	—	0.671875	— 17.066
3/16	—	0.1875	— 4.762	11/16	—	0.6875	— 17.462
	13/64	0.203125	— 5.159	45/64	—	0.703125	— 17.859
7/32	—	0.21875	— 5.556	23/32	—	0.71875	— 18.256
	15/64	0.234375	— 5.953	47/64	—	0.734375	— 18.653
1/4	—	0.2500	— 6.350	3/4	—	0.7500	— 19.050
	17/64	0.265625	— 6.747	49/64	—	0.765625	— 19.447
9/32	—	0.28125	— 7.144	25/32	—	0.78125	— 19.844
	19/64	0.296875	— 7.541	51/64	—	0.796875	— 20.241
5/16	—	0.3125	— 7.938	13/16	—	0.8125	— 20.638
	21/64	0.328125	— 8.334	53/64	—	0.828125	— 21.034
11/32	—	0.34375	— 8.731	27/32	—	0.84375	— 21.431
	23/64	0.359375	— 9.128	55/64	—	0.859375	— 21.828
3/8	—	0.3750	— 9.525	7/8	—	0.8750	— 22.225
	25/64	0.390625	— 9.922	57/64	—	0.890625	— 22.622
13/32	—	0.40625	— 10.319	29/32	—	0.90625	— 23.019
	27/64	0.421875	— 10.716	59/64	—	0.921875	— 23.416
7/16	—	0.4375	— 11.112	15/16	—	0.9375	— 23.812
	29/64	0.453125	— 11.509	61/64	—	0.953125	— 24.209
15/32	—	0.46875	— 11.906	31/32	—	0.96875	— 24.606
	31/64	0.484375	— 12.303	63/64	—	0.984375	— 25.003
1/2	—	0.5000	— 12.700	1	—	1.000	— 25.400
	1 mm = 0.03937 in.			0.001 in. = 0.0254 mm			

U.S to Metric Conversions

	To Convert	Into	Multiply By
Linear Measurement	Miles	Kilometers	1.609
	Yards	Meters	0.9144
	Feet	Meters	0.3048
	Feet	Centimeters	30.48
	Inches	Meters	0.0254
	Inches	Centimeters	2.54
	Inches	Millimeters	25.4
Area	Square Miles	Square Kilometers	2.59
	Square Feet	Square Meters	0.0929
	Square Inches	Square Centimeters	6.452
	Acre	Hectare	0.4047
Volume	Cubic Yards	Cubic Meters	0.7646
	Cubic Feet	Cubic Meters	0.02832
	Cubic Inches	Cubic Centimeters	16.39
Weight	Tons (Short)	Metric Tons	0.9078
	Pounds	Kilograms	0.4536
	Ounces (Avdp.)	Grams	28.3495
Pressure	Pounds/Sq. In.	Kilopascal	6.895
	Pounds/Sq. In.	Bar	0.069
Work	Foot-pounds	Newton-Meters	1.356
	Foot-pounds	Kilogram-Meters	0.1383
	Inch-pounds	Kilogram-Centimeters	1.152144
Liquid Volume	Quarts	Liters	0.9463
	Gallons	Liters	3.785
Liquid Flow	Gallons/Minute	Liters/Minute	3.785
Temperature	Fahrenheit	Celsius	1. Subtract 32°
			2. Multiply by 5/9

Torque Specifications



Use these torque values when specific torque values are not given. DO NOT use these values in place of

specified values. Torque values listed are for lubricated threads. Plated threads are considered to be lubricated.

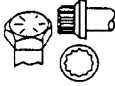
Capscrew Markings and Torque Values - U.S. Customary

SAE Grade Number	5				8			
Capscrew Head Markings								
Capscrew Body Size	Capscrew Torque - Grade 5				Capscrew Torque - Grade 8			
	Cast Iron		Aluminum		Cast Iron		Aluminum	
	ft-lb	Nm	ft-lb	Nm	ft-lb	Nm	ft-lb	Nm
1/4-20 -28	7 9	9 12	6 7	8 9	11 13	15 18	9 10	12 14
5/16-18 -24	15 17	20 23	12 14	16 19	22 24	30 33	18 19	24 25
3/8-16 -24	30 30	40 40	20 25	25 35	40 45	55 60	30 35	40 45
7/16-14 -20	45 50	60 65	35 40	45 55	65 70	90 95	50 55	65 75
1/2-13 -20	70 75	95 100	55 60	75 80	95 110	130 150	75 90	100 120
9/16-12 -18	100 110	135 150	80 85	110 115	140 155	190 210	110 125	150 170
5/8-11 -18	135 155	180 210	110 120	150 160	190 215	255 290	150 170	205 230
3/4-10 -16	240 270	325 365	190 210	255 285	340 380	460 515	270 300	365 410
7/8-9 -14	360 390	490 530	280 310	380 420	550 610	745 825	440 490	600 660
1-8 -14	530 590	720 800	420 480	570 650	820 890	1100 1200	660 710	890 960

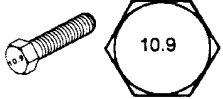
Capscrew Markings and Torque Values – Metric

Commercial Steel Class	8.8				10.9				12.9			
Capscrew Head Markings												
Thread Diameter mm	Capscrew Torque - Class 8.8				Capscrew Torque - Class 10.9				Capscrew Torque - Class 12.9			
	Cast Iron		Aluminum		Cast Iron		Aluminum		Cast Iron		Aluminum	
	ft-lb	Nm	ft-lb	Nm	ft-lb	Nm	ft-lb	Nm	ft-lb	Nm	ft-lb	Nm
6	5	9	4	7	9	14	7	11	9	14	7	11
7	9	14	7	11	14	18	11	14	18	23	14	18
8	18	25	14	18	23	32	18	25	27	36	21	28
10	30	40	25	30	45	60	35	45	50	70	40	55
12	55	70	40	55	75	105	60	80	95	125	75	100
14	85	115	65	90	120	160	95	125	145	195	110	150
16	130	180	100	140	175	240	135	190	210	290	165	220
18	170	230	135	180	240	320	185	250	290	400	230	310



EQUIPMENT OPERATION AND SERVICE HISTORY REPORT
for
GREENSMASTER® 1000

TORO Model and Serial Number: _____ - _____

Engine Numbers: _____

Differential Numbers: _____

Date Purchased: _____ Warranty Expires _____

Purchased From: _____

Contacts: Parts _____ Phone _____

 Service _____ Phone _____

 Sales _____ Phone _____

See your TORO Distributor/Dealer for other Publications, Manuals, and Videos from The TORO Company.

GREENSMASTER® 1000 Maintenance Schedule

Minimum Recommended Maintenance Intervals:

Maintenance Procedure	Maintenance Interval & Service			
Service Air Filter Pre-Cleaner	Every 25hrs	Every 50hrs	Every 100hrs	Every 200hrs
Lubricate All Grease Fittings				
Check for loose Fasteners	<i>A Level</i>			
Clean Fuel Filter and Sediment Bowl				
Adjust Traction Drive Belts	<i>B Level Service</i>			
† Change Engine Oil				
¹ Clean Combustion Chamber				
¹ Replace Spark Plug				
Check Cut-Off Bar Adjustment	<i>C Level Service</i>			
Service Air Cleaner Filter				
² Clean Combustion Chamber				
² Replace Spark Plug	<i>D Level Service</i>			
Adjust Valves and Torque Head Bolts				
† Initial Break in at 20 hours				
¹ Interval for Engine Model: FG150				
² Interval for Engine Model: FE120				
Replace All Interlock Switches	Annual Recommendations: Item listed is recommended every 2 years.			

(See Operator's and Service Manual for specifications and procedures)

GREENSMaster® 1000 Daily Maintenance Check List

Unit Designation: _____

Daily Maintenance:(duplicate this page for routine use)

TORO ID#: _____ - _____

Maintenance Check Item	Daily Maintenance Check For Week Of _____						
	MON _____ HRS	TUES _____ HRS	WED _____ HRS	THURS _____ HRS	FR _____ HRS	SAT _____ HRS	SUN _____ HRS
✓ Safety Interlock Operation							
✓ Park Brake Operation							
✓ Fuel Level							
✓ Engine Oil Level							
✓ Air Filter Pre-Cleaner							
Clean Engine Cooling Fins							
✓ Unusual Engine Noises							
✓ Unusual Operating Noises							
✓ Reel-to-Bedknife Adjustment							
✓ Height-of-Cut Adjustment							
Lubricate All Grease Fittings ¹							
Touch-up damaged paint							

¹ = Immediately after every washing, regardless of the interval listed.

Notation for areas of concern:

Inspection performed by: _____

Item	Date	Information
1		
2		
3		
4		
5		
6		
7		

(See Operator's and Service Manual for specifications and procedures)

GREENSMaster® 1000 Supervisor Maintenance Work Order

Date: _____

(duplicate this page for routine use)

Unit Designation:	TORO I.D. #: _____	Remarks:
Hours:	Service to perform (circle): A B C D Other	
Technician:		

A -Service (every 25 hours)

- Lubricate All Grease Fittings
- Service Air Filter Pre-Cleaner
- Check for Loose Fasteners
- _____
- _____
- _____
- _____

B -Service (every 50 hours)

- Change Engine Oil
- Adjust Belts
- Clean Fuel Filter & Sediment Bowl
- A-Service** required
- _____
- _____
- _____

C -Service (every 100 hours)

- Clean Combustion Chamber¹
- Replace Spark Plug¹
- Check Cut-Off Bar Adjustment
- Service Air Cleaner Filter
- A and B Service** required
- _____
- _____

D -Service (every 200 hours)

- Clean Combustion Chamber²
- Replace Spark Plug²
- Adjust Valves and Torque Head Bolts
- A, B and C Service** required
- _____
- _____
- _____

Other - Annual Service and Specials

- Replace all Interlock Switches
- _____
- _____
- _____
- _____
- _____
- _____
- _____

Additional Servicing Items

- _____
- _____
- _____
- _____
- _____
- _____
- _____

¹ Interval for Engine Model: FG150

² Interval for Engine Model: FE120

(See Operator's and Service Manual for specifications and procedures)



Chapter 3

Engine

Table of Contents

INTRODUCTION	2	SERVICE AND REPAIRS	8
SPECIFICATIONS	3	Engine Oil	8
GENERAL INFORMATION	4	Spark Plug and Ignition Components	8
Filling the Fuel Tank	4	Air Cleaner	9
Fuel Shut-off Valve	5	Fuel Filter	9
ADJUSTMENTS	6	Engine Removal and Installation	10
Throttle Linkage Adjustment	6	Lubrication	13
Clutch Control Adjustment	6	Kawasaki FE161 & FE170 Service Manual and	
Adjusting V-belts	7	Kawasaki FE120 Service Manual Supplement	

Introduction

This Chapter gives information about specifications, maintenance, troubleshooting, testing, and repair of the gasoline engine used in the Greensmaster 1000/1600 mower.

Most repairs and adjustments require tools which are commonly available in many service shops. Special tools are described in the Kawasaki FE161 & FE170 Service Manual and Kawasaki FE120 Service Manual

Supplement. The use of some specialized test equipment is explained. However, the cost of the test equipment and the specialized nature of some repairs may dictate that the work be done at an engine repair facility.

Service and repair parts for Kawasaki engines are supplied through your local Toro distributor. If no parts list is available, be sure to provide your distributor with the Toro model and serial number.

Specifications

Item	Description
Make / Designation	Kawasaki, 4–stroke, OHV, single cylinder, air–cooled, gasoline engine, FE120G
Bore x Stroke mm (in.)	60 x 44 (2.36 x 1.73)
Total Displacement cc (cu. in.)	124 (7.6)
Compression Ratio	8.4:1
Maximum Output kw (HP)	2.8 (3.7)
Rated Output kw (HP)	2.2 (3.0)
Carburetor	Float feed fixed main jet
Governor	Mechanical flyweight
Idle Speed (no load)	1600 ± 100 RPM (at crankshaft) or 800 ± 50 RPM (at camshaft)
High Idle (no load)	3600 ± 100 RPM (at crankshaft) or 1800 ± 50 RPM (at camshaft)
Direction of rotation	Clockwise (facing PTO shaft)
Fuel	Un–leaded automotive grade gasoline
Fuel Tank Capacity liter (U.S. qt.)	2.5 (2.6)
Engine Oil	See General Information
Lubrication System	Splash type
Oil Capacity liter (U.S. qt.)	0.6 (0.63)
Air Cleaner	Dual element
Ignition System	Transistorized flywheel magneto with ignition advancing
RFI Suppressor	Radio suppressor plug cap and plug
Dry Weight kg (U.S. lb)	14.6 (32.2)

General Information

Filling the Fuel Tank



DANGER

Because gasoline is flammable, caution must be used when storing or handling it. Do not fill the fuel tank while engine is running, hot, or in an enclosed area. Vapors may build up and be ignited by a spark or flame source many feet away. **DO NOT SMOKE** while filling the fuel tank to prevent the possibility of an explosion. Always fill fuel tank outside. Wipe up any spilled gasoline before starting the engine. Use a funnel or spout to prevent spilling gasoline. Fill tank no higher than to the bottom of filter screen. **DO NOT OVER FILL.** Store gasoline in a clean safety approved container and keep the cap on the container. Keep gasoline in a cool, well ventilated place; never in an enclosed area such as a hot storage shed. To assure volatility, do not buy more than a 30 day supply of gasoline. Gasoline is a fuel for internal combustion engines; therefore do not use it for any other purpose. Since many children like the smell of gas, keep it out of their reach because the fumes are explosive and dangerous to inhale.



Figure 1

1. Fuel tank cap

IMPORTANT: Never use methanol, gasoline containing methanol, gasoline containing more than 10% ethanol, gasoline additives, premium gasoline, or white gas. Engine fuel system damage could result.

1. Park mower on a level surface. Make sure engine is OFF.
2. Clean around fuel tank cap and remove cap from tank (Fig. 1). Using unleaded gasoline, fill fuel tank to bottom of filter screen. **DO NOT OVER FILL.**
3. Install fuel tank cap. Wipe up any spilled gasoline.

Fuel Shut-off Valve

The valve is located on the left front side of the engine. It has two positions: CLOSED and OPEN. Position valve to the closed position when storing or transporting the machine. Open valve before starting the engine. Open valve before starting the engine.

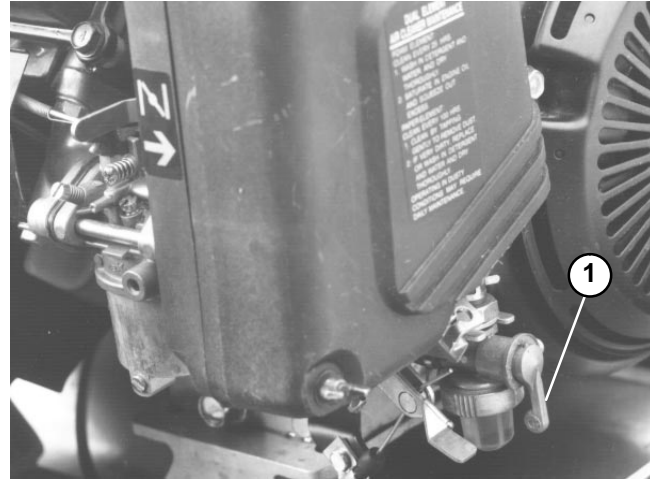

Figure 2
1. Fuel shut-off valve

Adjustments

Throttle Control Adjustment

If a new throttle cable must be installed or the cable is out of adjustment, adjust the cable as follows:

1. Park mower on a level surface. Make sure engine is OFF. Remove high tension lead from the spark plug.
2. Move throttle lever to the SLOW position.
3. Loosen throttle cable screw securing the throttle cable to the governor lever.

Note: Engine speed is measured at the input drive pulley (Fig. 6). Actual engine speed is twice the input drive pulley speed.

4. The governor lever will move to the slow idle position if it is improperly adjusted.

A. Check low idle speed setting with a tachometer. **Low idle speed should be 750 to 850 rpm.** Adjust low speed idle screw in or out to attain the correct speed setting.

B. Check high idle speed setting with a tachometer. **High idle speed should be 1750 to 1850 rpm.** Adjust high speed idle screw in or out to attain the correct speed setting.

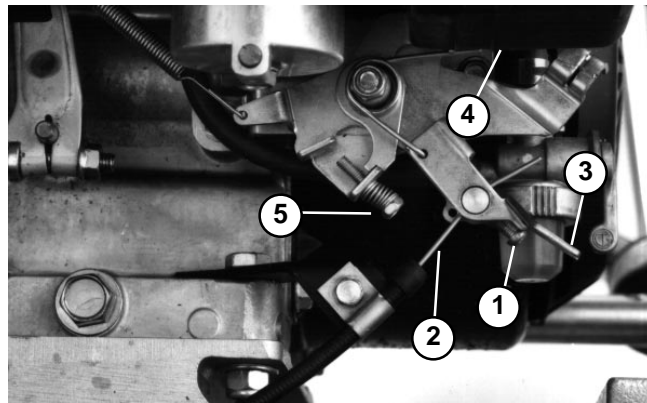

Figure 2

- | | |
|-------------------------|--------------------------|
| 1. Throttle cable screw | 4. Low speed idle screw |
| 2. Throttle cable | 5. High speed idle screw |
| 3. Governor lever | |

5. Make sure throttle lever is in the SLOW position and the governor lever is against the low speed idle screw.

6. Tighten throttle cable screw securing the throttle cable to the governor lever.

Clutch Control Adjustment

If clutch control does not engage or it slips during operation, an adjustment is required.

1. Park mower on a level surface. Make sure engine is OFF. Remove high tension lead from the spark plug.
2. Move traction control to DISENGAGED position.
3. Loosen retainer securing V-belt cover and pivot cover open.
4. To increase cable tension, loosen front cable jam nut and tighten back cable jam nut (Fig. 3) until a force of 7 to 9 lbs (31 to 40 N) is required to engage clutch control. The force should be measured at the control knob.
5. Tighten front cable jam nut.
6. Close cover and secure retainer.
7. Check control operation.

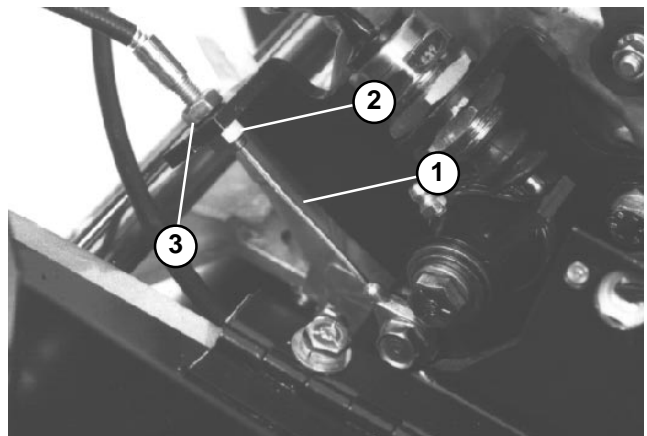

Figure 3

- | | |
|------------------|-----------------|
| 1. Clutch | 3. Back jam nut |
| 2. Front jam nut | |

Adjusting V-belts

To adjust belt tension on V-belts (Fig. 5), first check adjustment of clutch control. Refer to Clutch Control in this section. If unable to attain the 7 to 9 lbs (31 to 40 N) of force that is required in adjusting the clutch control, proceed to the next step.

1. Park mower on a level surface. Make sure engine is OFF. Remove high tension lead from the spark plug.

2. Loosen retainer securing the V-belt cover and pivot cover open.

3. To increase V-belt tension, loosen cap screws securing the engine to the engine base (Fig. 12). Move engine backwards in slots. **DO NOT OVER TENSION BELTS.** Tighten cap screws.

4. Check that a force of 7 to 9 lbs (31 to 40 N) is required to engage the clutch control. Adjust engine in slots as necessary to get required tension on V-belts.

5. After tensioning V-belts, check alignment of the input drive pulley and input shaft pulley with a straight edge.

A. Inside pulley faces should be flush to each other to within 0.030 inch (0.762 mm) maximum (Fig. 6).

B. If pulleys are misaligned, loosen cap screws securing the engine mounting base to the mower frame. Slide engine from side to side until the pulleys are aligned (Fig. 7).

6. Tighten cap screws and recheck alignment.

7. Close V-belt cover and secure retainer.

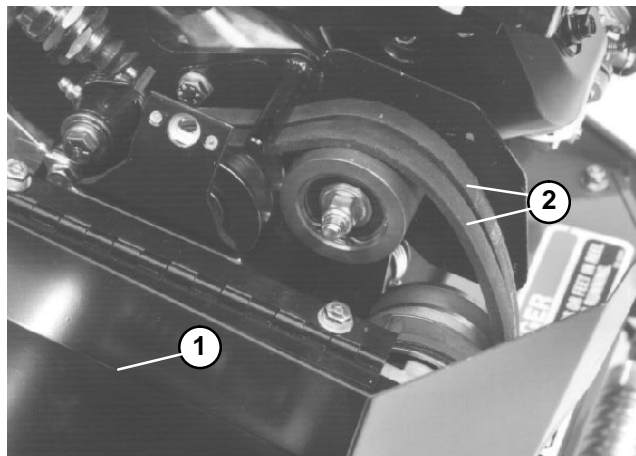

Figure 5

1. V-belt cover 2. V-belts

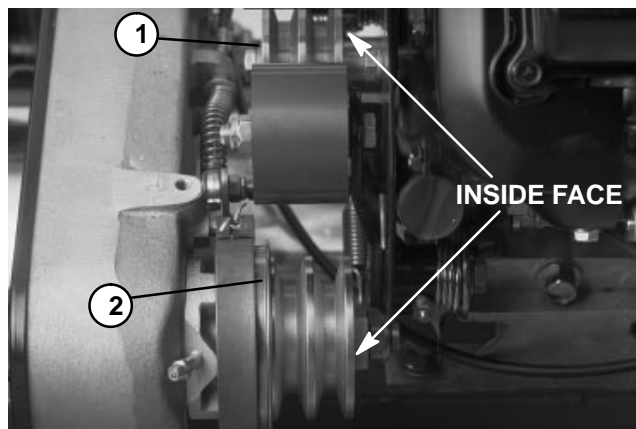

Figure 6

1. Input drive pulley 2. Input shaft pulley

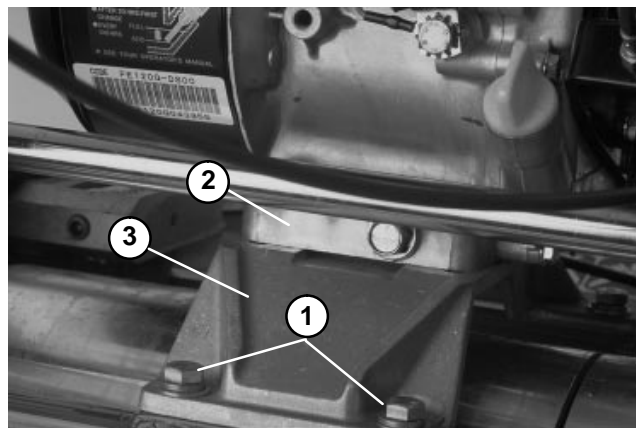

Figure 7

1. Cap screws 3. Engine base
2. Engine

Engine

Service and Repairs

Engine Oil

The TORO Company recommends that the oil level be checked each time the mower is used or after every 5 operating hours. Initially, change oil after the first 20 hours of operation; thereafter, change oil after every 50 hours of operation. **More frequent oil changes are required in dusty or dirty conditions.**

Checking the Oil Level:

1. Park mower on a level surface. Make sure engine is OFF.
2. Position mower so the engine is level. Clean around the oil level gauge.
3. Remove oil level gauge by rotating it counterclockwise.
4. Wipe oil level gauge clean and insert it into the filler port. Do not screw it into the port. Remove and check level of the oil. If the oil level is low, add only enough oil (see chart below for proper viscosity) to raise the level to the filler opening.

Use any high quality detergent oil having the American Petroleum Institute (API) "service classification"— MS or SG.

Temperature	Oil Viscosity
50° or below	SAE 10W30 wt.
50° to 95°	SAE 10W30 wt. or 30 wt.
Above 95°	SAE 40

5. Reinstall oil level gauge and wipe up any spilled oil.

Changing the Oil:

1. Start and run engine for a few minutes to warm the engine oil.
2. Place a drain pan at the rear of machine under the drain plug. Remove drain plug.
3. Push down on handle to tip mower and engine backward, allowing more oil to run into the drain pan.
4. Reinstall drain plug and refill crankcase with proper oil: refer to **Checking the Oil Level**. The crankcase holds 6.3 qt (6.0 l).

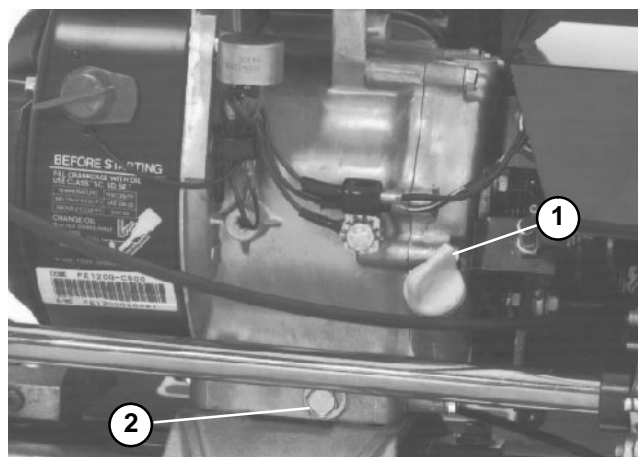

Figure 8

1. Oil level gauge

2. Drain plug

Spark Plug and Ignition Components

Service of the spark plug and other ignition components is covered in Chapter 5 – Electrical System.

Air Cleaner

Normally, clean air filter precleaner (foam element) after every 25 operating hours and the air cleaner filter (paper element) after every 100 operating hours. More frequent cleaning is required when the mower is operated in dusty or dirty conditions. Replace air cleaner filter (paper element) after 200 operating hours.

1. Park mower on a level surface. Make sure engine is OFF. Remove high tension lead from the spark plug.

2. Remove wing nuts securing the air cleaner cover to air cleaner and remove cover. Clean cover thoroughly (Fig. 9).

3. If the foam element is dirty, remove it from the paper element (Fig. 10). Clean foam element thoroughly.

A. WASH element in a solution of liquid soap and warm water. Squeeze it to remove dirt. Do not twist element because foam may tear.

B. DRY by wrapping the element in a clean rag. Squeeze rag and foam element to dry.

C. SATURATE element with clean engine oil. Squeeze element to remove excess oil and to distribute oil uniformly. An oil damp element is desirable.

4. When servicing the foam element, check condition of the paper element. Clean or replace as required.

5. Reinstall foam element, paper element, and air cleaner cover. Tighten wing nuts.

IMPORTANT: Do not operate engine without air cleaner element because extreme engine wear and damage will likely result.

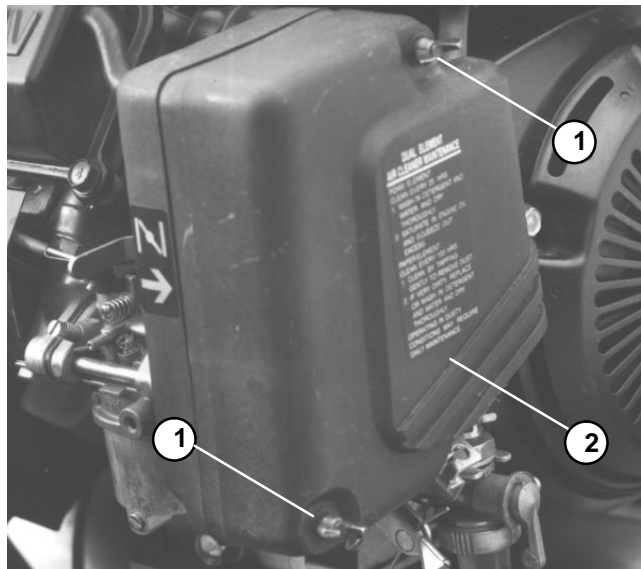

Figure 9

1. Wing nut

2. Air cleaner cover

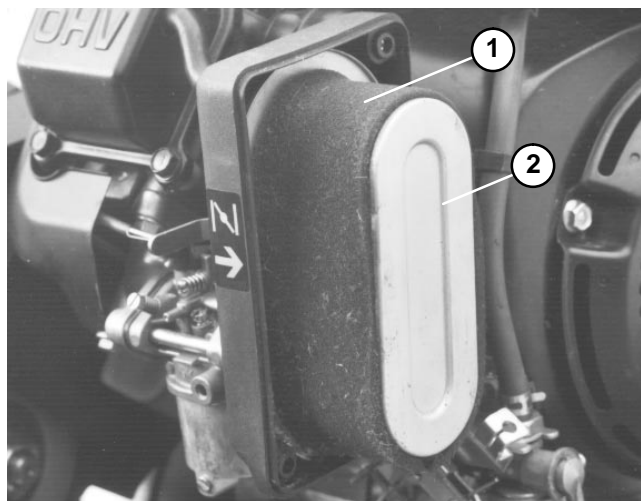

Figure 10

1. Foam element

2. Paper element

Fuel Filter

Clean fuel filter after every 50 hours operation.

1. Close fuel shut off valve and unscrew bowl from the filter body. Remove filter element.

2. Clean bowl and filter element in clean gasoline.

3. Reinstall filter element and bowl. Open fuel shut-off valve.

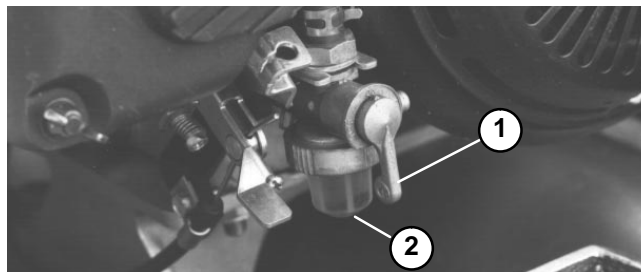

Figure 11

1. Fuel shut-off valve

2. Bowl

Engine Removal and Installation

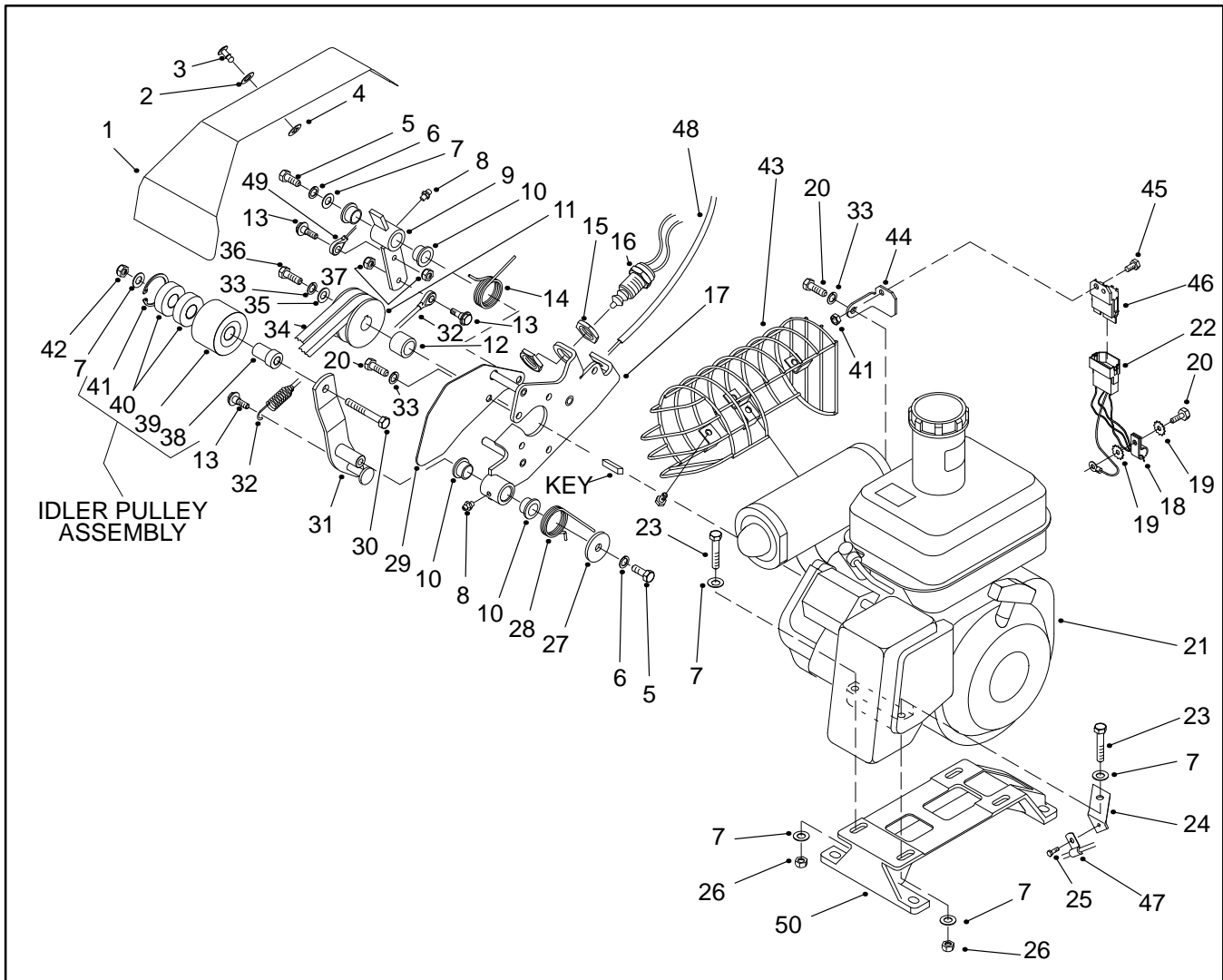

Figure 12

- | | | |
|-------------------------|----------------------------|-------------------------------------|
| 1. Bellcrank cover | 18. R-clamp | 35. Washer |
| 2. Flat washer | 19. Lock washer | 36. Cap screw |
| 3. Stud | 20. Cap screw | 37. Lock nut |
| 4. Retainer | 21. Engine | 38. Pulley support spacer |
| 5. Capscrew | 22. Wire harness | 39. Idler pulley |
| 6. Lock washer | 23. Capscrew | 40. Ball bearing |
| 7. Flat washer | 24. Throttle cable bracket | 41. Retaining ring |
| 8. Grease fitting | 25. Washer head screw | 42. Lock nut |
| 9. Lever | 26. Lock nut | 43. Muffler guard (European models) |
| 10. Bushing | 27. Washer | 44. Module bracket |
| 11. Input drive pulley | 28. Clutch torsion spring | 45. Cap screw |
| 12. Engine shaft spacer | 29. Belt shield | 46. Interlock module |
| 13. Shoulder bolt | 30. Cap screw | 47. Throttle cable and bracket |
| 14. Torsion spring | 31. Clutch lever | 48. Clutch cable |
| 15. Jam nut | 32. Cable link assembly | 49. Clutch cable eyelet |
| 16. Clutch switch | 33. Lock washer | 50. Engine base |
| 17. Clutch bracket | 34. V-belt (matched set) | |

Removal

1. Make sure machine is parked on a level surface with the engine OFF. Remove high tension lead from the spark plug to prevent the engine from starting. Close fuel shut-off valve.

2. Remove pulley V-belts (Fig. 12).

A. Make sure clutch is DISENGAGED so the V-belts (34) are slackened. Make sure service brake is DISENGAGED so the input shaft pulley can turn.

B. Open bellcrank cover (1) on the counter shaft housing to get access to the clutch. Remove V-belts one at a time by sliding the belt off the idler pulley (39) first.

3. Remove clutch cable (Fig. 12).

A. Remove shoulder bolt (13) and lock nut (37) from the clutch cable eyelet (49) and lever (9).

B. Loosen lower jam nut holding the clutch cable to the clutch bracket. Remove clutch cable from the clutch bracket and clear of engine (Fig. 13).

4. Remove throttle cable from engine.

A. Loosen screw on governor lever enough to slide the throttle cable out of the nut (Fig. 14).

B. Remove cap screw (23), flat washers (7), and lock nut (26) from the engine base (49) and throttle cable bracket (24). Pull throttle cable (47) and bracket clear of the engine (Fig. 12).

5. Remove engine from the engine base.

A. Scribe a mark on the engine base at the bottom of the engine for reassembly purposes (Fig. 15).

B. Disconnect both black\white wires on the clutch switch (16) from both brown wires.

C. Remove remaining cap screws (23), flat washers (7), and lock nuts (26) from the engine base (49). Remove the engine from the cutting unit.

6. The bellcrank assembly can be removed from the engine with minimum disassembly (Fig. 12).

A. Remove cap screw (36), lock washer (33), and washer (35) from the engine shaft. Remove pulley (11), key, and spacer (12) from the engine shaft.

B. Remove five cap screws (20) and lock washers (33) securing the belt shield (29) and clutch bracket (17) to the engine block.

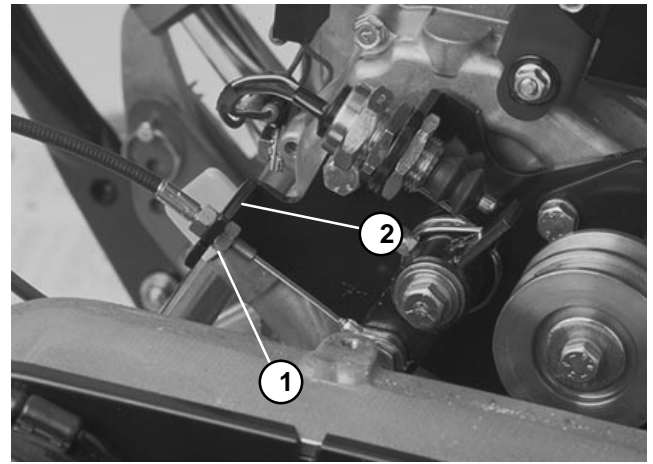

Figure 13

1. Lower jam nut 2. Clutch bracket

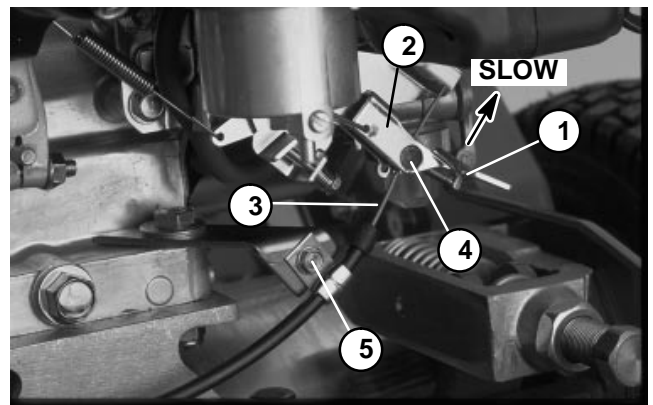

Figure 14

1. Screw 4. Nut
2. Governor lever 5. Washer head screw
3. Throttle cable

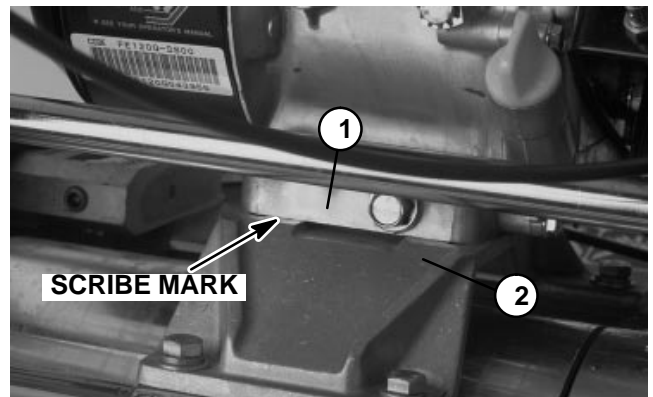

Figure 15

1. Engine block 2. Engine base

C. Remove complete bellcrank assembly from the engine.

Reinstalling the Engine

1. Make sure machine is parked on a level surface. The machine may be placed on a large work bench to make engine installation and adjustment easier. Remove high tension lead from the spark plug.

2. Make sure that all parts removed from the engine during maintenance or rebuilding are properly reinstalled to the engine.

3. Make sure bellcrank cover (1) is open on the counter shaft housing to get access to the clutch (Fig. 12).

4. If the bellcrank assembly was removed from the engine (21), reassembly as follows (Fig. 12):

A. Position clutch bracket (17) to the engine with the long arm of the clutch torsion spring (28) under the engine.

B. Position belt shield (29) to the engine. Secure belt shield and clutch bracket to the engine with five cap screws (20) and lock washers (33).

C. Hook short end of clutch torsion spring around the post on the clutch bracket.

D. Place engine shaft spacer (12) on the engine shaft and reinstall key. Apply never seize to the shaft.

E. Place input drive pulley (11) on the engine shaft with the counter bore out. Secure pulley to the shaft with cap screw (36), lock washer (33), and washer (35).

5. Reinstall engine (21) to engine base (50) (Fig. 12).

A. Position engine on the engine base with the input drive pulley towards the differential housing.

B. Install four cap screws (23) and flat washers (7) through the engine and engine base. Install throttle cable bracket (24) under the left front cap screw. Put flat washer and lock nut (26) on each cap screw and hand tighten.

C. Use scribe mark on engine block to align engine. The distance between engine output shaft center and power shaft center should be from 5.11 to 5.23 inches (130 to 133 mm). Inside pulley faces should be flush to each other to within 0.030 inch (0.762 mm) maximum (Fig. 16).

D. Tighten cap screws ensuring the engine alignment does not change.

E. Reconnect both black/white wires on the clutch switch (16) to both brown wires.

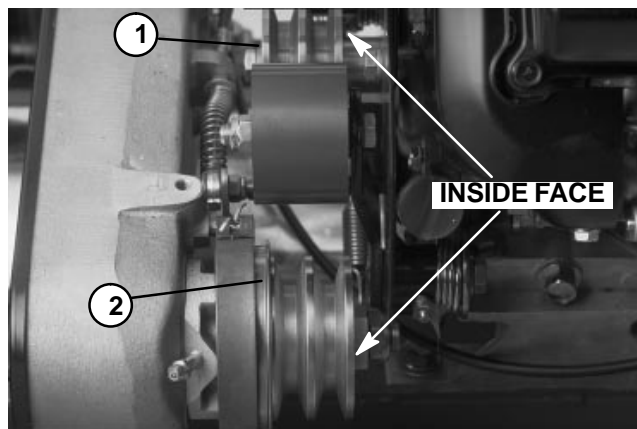

Figure 16

1. Input drive pulley 2. Input shaft pulley

6. Reconnect and adjust throttle cable (Fig. 14).

A. Make sure screw on governor level is loose enough to slide the throttle cable into of the nut.

B. Loosen washer head screw enough to allow the throttle cable to slide through small clamp

C. Position throttle control lever to the SLOW position and governor lever all the way up to the **slow** position.

D. Tighten screw on throttle lever and washer head screw to the small clamp securing the throttle cable.

7. Reinstall clutch cable.

A. Reinstall clutch cable into notch of clutch bracket and clear of engine. Tighten lower jam nut holding clutch cable to clutch bracket (Fig. 13).

B. Place shoulder bolt (13) through the clutch cable eyelet (49) and lever (9). Secure shoulder bolt with lock nut (37) (Fig. 12).

8. Reinstall pulley V-belts (Fig. 12).

A. Make sure clutch is **DISENGAGED**. Make sure service brake is **DISENGAGED** so the input shaft pulley can turn.

B. Install V-belts (34) one at a time by placing a belt into the inner groove of the input drive pulley (11) first. Place the second belt into the outer groove of the input drive pulley and then the outer groove of the input shaft pulley. Place the loose end of the first belt into the inner groove of the input drive pulley.

Lubrication

Both fittings on the bellcrank assembly should be greased at least every 25 hours. Lubricate using No. 2 multipurpose lithium base grease. A hand operated grease gun is recommended for best results.

1. Park mower on a level surface. Make sure engine is OFF. Remove high tension lead from the spark plug.
2. Wipe each grease fitting with a clean rag.

IMPORTANT: Do not apply too much pressure or grease seals will become permanently damaged.

3. The grease fitting locations are the clutch lever pivot and the clutch spring end of the clutch bracket.
4. Wipe off excess grease.

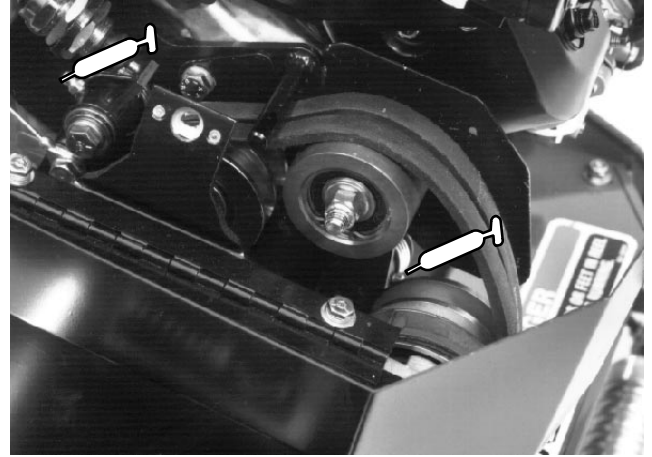

Figure 17



Traction and Reel Drive Systems

Table of Contents

SPECIFICATIONS	2	Differential Axle Pulley and Bearing	14
SPECIAL TOOLS	3	Drum Shaft Bearing	15
Drum Bushing Tool Kit	3	Drum Assembly with Bearings	16
ADJUSTMENTS	4	Drum Assembly with Bushings	18
Differential Belt Adjustment	4	Counter Shaft Assembly	20
Drum Drive Belt Adjustment	5	Brake Band Replacement	21
Reel Drive Belt Adjustment	6	Power Shaft Bearing	22
Service/Park Brake Adjustment	7	Differential Axle Bearing (Countershaft Housing)	23
SERVICE AND REPAIRS	8	Differential Idler and Bearing	24
Reel Drive Assembly	8	Differential Assembly and Pulley	25
Reel Drive Belt Replacement	9	Differential Belt Replacement – Models 04051, 04052, and 04060	29
Reel Drive Idler Pulley and Bearing	9	Differential Belt Replacement – Model 04050 ..	30
Clutch Bearing	10	Lubrication	35
Drum Drive Assembly	12		
Drum Drive Belt Replacement	13		
Drum Drive Idler Pulley and Bearing	13		

Traction and Reel
Drive System

Specifications

Item	Description
Traction Drive	Engine to countershaft drive has two "A" section V-belts. Countershaft to differential drive has 5 mm pitch timing belt. Differential to drum drive has a 8 mm pitch timing belt.
Differential	Peerless series 100
Brake	Band drum
Traction Drum	Dual cast aluminum, 7.5 inch (19.1 cm) diameter
Reel Clutch	Jaw type

Special Tools

Order special tools from the *TORO SPECIAL TOOLS AND APPLICATIONS GUIDE (COMMERCIAL PRODUCTS)*.

Some tools may have been supplied with your mower or available as TORO parts. Some tools may also be available from a local supplier.

Drum Bushing Tool Kit – TOR4060

Note: This kit is used on mowers with drums that have bushings instead of bearings. The kit is used for models 04051 and 04052 – 50101 to 59999 only.

This kit contains all the tools required to install and properly size the drum bushings to factory standards. These tools come as a set in a plastic tool case, or they may be ordered individually.

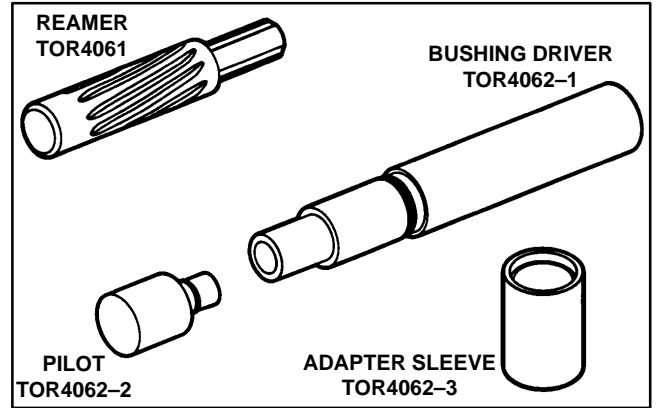

Figure 1

Adjustments

Differential Belt Adjustment

1. Park mower on a level surface. Make sure engine is OFF. Remove high tension lead from the spark plug.

2. Check tension by depressing belt at the mid span between pulleys with 5 to 6 lbs (22 to 27 N) of force. The belt should deflect 1/4 inch. If deflection is incorrect, proceed to next step. If deflection is correct, continue operation.

3. To adjust belt tension:

A. Remove capscrews securing the front and rear box covers to countershaft housing. Slide covers away from the housing to expose the belt (Fig. 2).

B. Loosen idler pulley cap screw on the engine side of the housing (Fig. 3).

C. Pivot idler pulley clockwise against the backside of the belt until desired belt tension is attained. **Do not over tension the belt (Fig. 2).**

D. Tighten cap screw to lock adjustment (Fig. 3).

E. Reinstall box covers by placing the covers in position. While maintaining a slight gap between the cover seal and the side plate, install each cap screw until the threads engage in the insert. The gap will allow visual alignment of the cap screw to the threaded insert. After all cap screws are installed, tighten them until the stand offs inside the covers contact the side plate. **Do not overtighten (Fig. 2).**

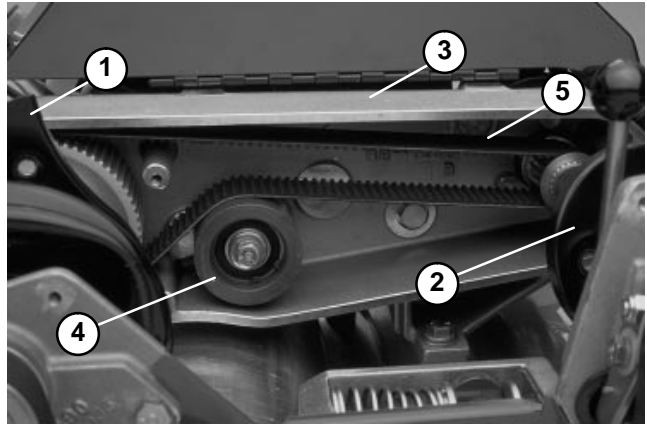

Figure 2

- | | |
|-------------------------|----------------------|
| 1. Front box cover | 4. Idler pulley |
| 2. Rear box cover | 5. Differential belt |
| 3. Countershaft housing | |

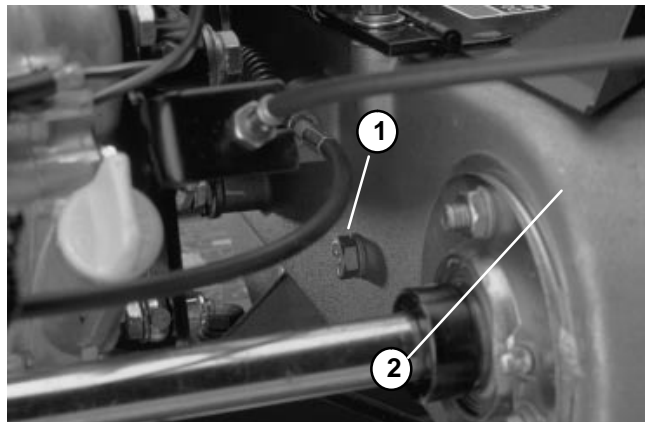

Figure 3

- | | |
|--------------|-------------------------|
| 1. Cap screw | 2. Countershaft housing |
|--------------|-------------------------|

Drum Drive Belt Adjustment

1. Park mower on a level surface. Make sure engine is OFF. Remove high tension lead from the spark plug.

2. Check tension by depressing belt at mid span between the pulleys with 4 to 5 lbs (18 to 22 N) of force. The belt should deflect 1/4 inch. If deflection is incorrect, proceed to next step. If deflection is correct, continue operation.

3. To adjust belt tension:

A. Remove wheels if installed.

B. Remove cap screws, lock washers, and belt covers from the side plates (Fig. 4).

C. Loosen idler pulley capscrew (Fig. 5).

D. Pivot the idler pulley clockwise against the backside of the belt until desired belt tension is attained. **Do not over tension belt (Fig. 6).**

E. Tighten cap screw to lock adjustment (Fig. 5).

Note: Make sure spacer is on the lower pulley before the belt cover is reinstalled.

F. Reinstall belt cover by placing the cover in position. While maintaining a slight gap between the cover seal and the side plate, install each cap screw until the threads engage in the insert. The gap will allow visual alignment of the cap screw to the threaded insert. After all capscrews are installed, tighten them until the stand offs inside the cover contact the side plate. **Do not overtighten (Fig. 6).**

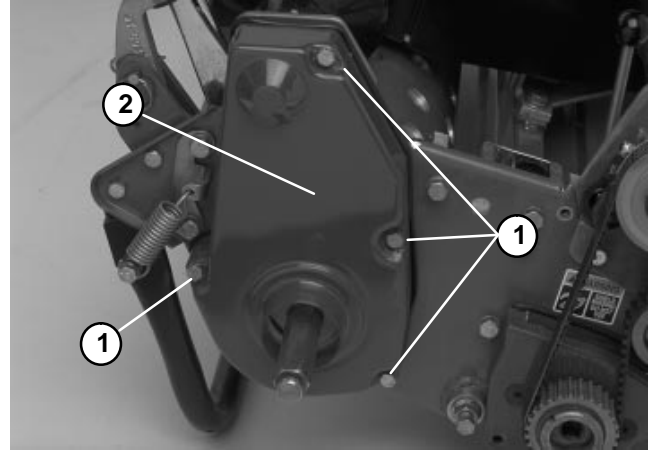

Figure 4

1. Cap screw & lock washer 2. Belt cover

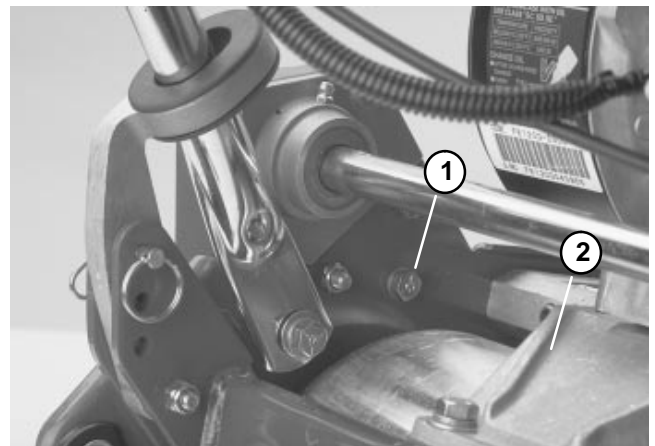

Figure 5

1. Cap screw 2. Engine base

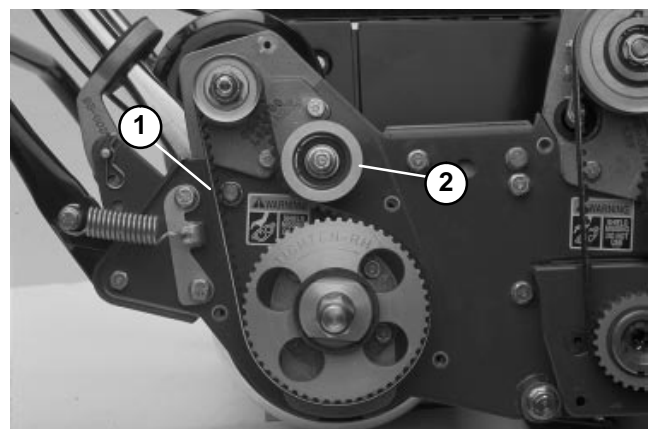

Figure 6

1. Drum drive belt 2. Idler pulley

Reel Drive Belt Adjustment

1. Park mower on a level surface. Make sure engine is OFF. Remove high tension lead from the spark plug.

2. Check tension by depressing the belt at mid span between pulleys with 4 to 5 lbs (18 to 22 N) of force. The belt should deflect 1/4 inch. If deflection is incorrect, proceed to next step. If deflection is correct, continue operation.

3. To adjust belt tension:

A. Remove cap screws, lock washers, and belt covers to expose the belt (Fig. 7).

B. Remove cap screws, flat washers, and nuts securing the grass shield to the shield brackets. Move grass shield to access the cap screw securing the idler pulley (Fig. 8).

C. Loosen idler pulley cap screw (Fig. 8).

D. Pivot the idler pulley clockwise against the back-side of the belt until desired belt tension is attained. **Do not over tension belt (Fig. 9).**

E. Tighten cap screw to lock adjustment (Fig. 8).

F. Reinstall belt cover by placing the cover in position. While maintaining a slight gap between the cover seal and the side plate, install each cap screw until the threads engage in the insert. The gap will allow visual alignment of the cap screw to the threaded insert. After all cap screws are installed, tighten them until the stand offs inside the cover contact the side plate. **Do not overtighten (Fig. 9).**

G. Reinstall grass shield to shield brackets with cap screws, flat washers, and lock nuts (Fig. 8).

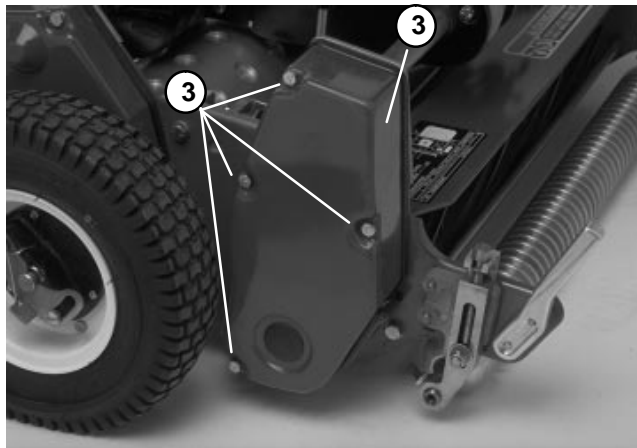

Figure 7

1. Cap screw & lock washer 2.

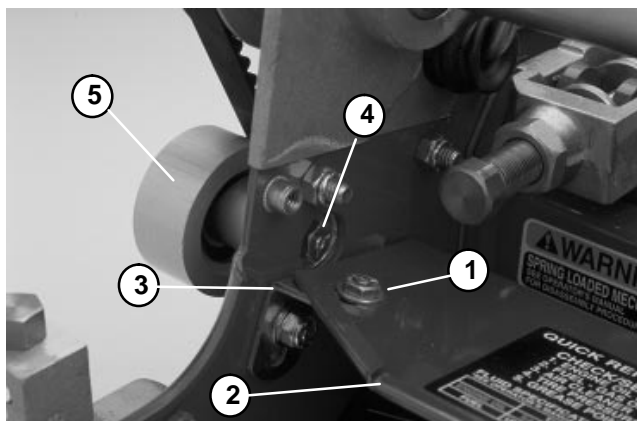

Figure 8

1. Cap screw, washer & nut 4. Cap screw
2. Grass shield 5. Idler pulley
3. Shield bracket

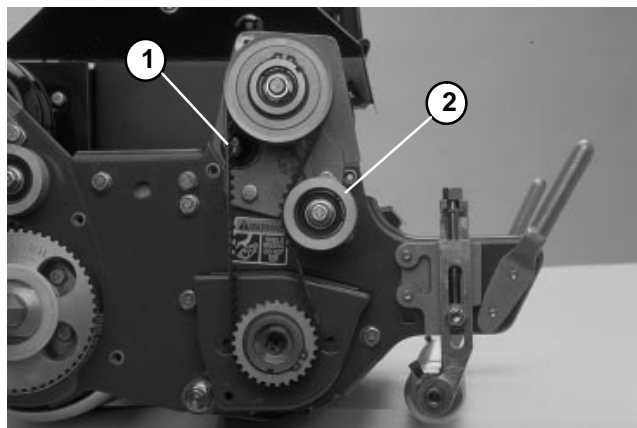

Figure 9

1. Reel drive belt 2. Idler pulley

Service/Park Brake Adjustment

If service/park brake slips when operated, an adjustment is required.

1. Park mower on a level surface. Make sure engine is OFF. Remove high tension lead from the spark plug.
2. Move service/park brake lever to the OFF position.

Note: Figure 10 is shown with the bellcrank cover removed for illustrative purposes. It is not necessary to remove the cover.

3. Loosen retainer securing the bellcrank cover. Pivot cover open.
4. To increase cable tension, loosen front cable jam nut and tighten back cable jam nut until a force of 3 to 5 lbs (13 to 22 N) is required to engage brake. The force should be measured at brake lever knob. **Do not over adjust, so brake band drags.**
5. Close cover and secure retainer.

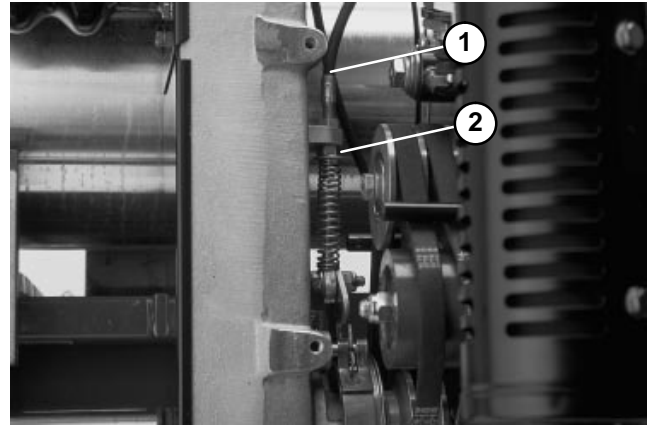

Figure 10

1. Brake cable

2. Front jam nut

Service and Repairs

Reel Drive Assembly

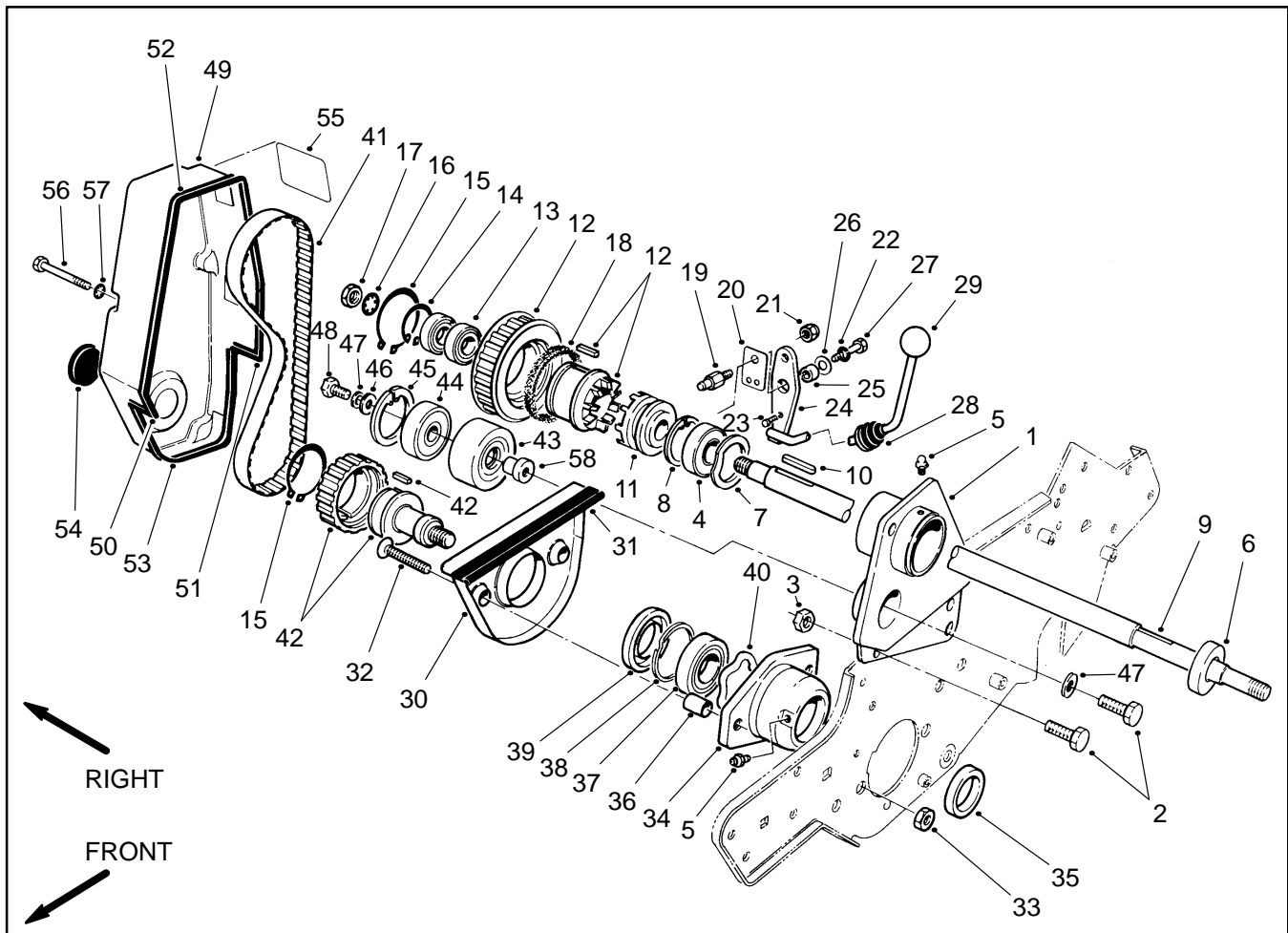

Figure 11

- | | | |
|--------------------------------|---------------------------|-------------------------------|
| 1. Clutch housing | 21. Lock nut | 40. Wave washer |
| 2. Cap screw | 22. Lock washer | 41. Reel drive belt |
| 3. Lock nut | 23. Drive screw | 42. Pulley and drive assembly |
| 4. Ball bearing | 24. Clutch lever | 43. Idler pulley |
| 5. Grease fitting | 25. Spacer | 44. Ball bearing |
| 6. Oil seal | 26. Washer | 45. Snap ring |
| 7. Wave washer | 27. Cap screw | 46. Flat washer |
| 8. Retaining ring | 28. Clutch boot | 47. Lock washer |
| 9. Power shaft | 29. Knob | 48. Cap screw |
| 10. Key (2) | 30. Grommer arm cover | 49. Reel drive cover |
| 11. Clutch jaw driver | 31. Cover trim | 50. Front seal strip |
| 12. Clutch and pulley assembly | 32. Flat head screw | 51. Rear seal strip |
| 13. Ball bearing | 33. Nut | 52. Upper seal strip |
| 14. Retaining ring | 34. Bearing housing | 53. Lower seal strip |
| 15. Retaining ring | 35. Seal | 54. Plug |
| 16. Lock washer | 36. Cover standoff | 55. Decal |
| 17. Jam nut | 37. Self-aligning bearing | 56. Cap screw |
| 18. Felt seal | 38. Retaining ring | 57. Washer |
| 19. Actuator pin | 39. Seal | 58. Pulley support spacer |

Reel Drive Belt Replacement

Removal

1. Park mower on a level surface. Make sure engine is OFF. Remove high tension lead from the spark plug.
2. Remove cap screws (56), washers (57) and reel drive cover (49) to expose reel drive belt (41) (Fig. 11).
3. Remove cap screws, flat washers, and nuts securing grass shield to shield brackets. Move grass shield to access the cap screw securing the idler pulley (Fig. 8).
4. Loosen cap screw (2) securing the pulley support spacer (58) (Fig. 11).
5. Pivot idler pulley counterclockwise away from the reel drive belt to loosen belt tension. Remove reel drive belt from the clutch pulley and drive pulley (Fig. 12).

Installation

1. Park mower on a level surface. Make sure engine is OFF. Remove high tension lead from the spark plug.
2. Place a new reel drive belt onto the clutch pulley and drive pulley (Fig. 12).

3. Adjust reel drive belt tension and reinstall reel drive cover (see Reel Drive Belt in the Adjustments section).
4. Reinstall grass shield to shield brackets with cap screws, flat washers, and lock nuts (Fig. 8).

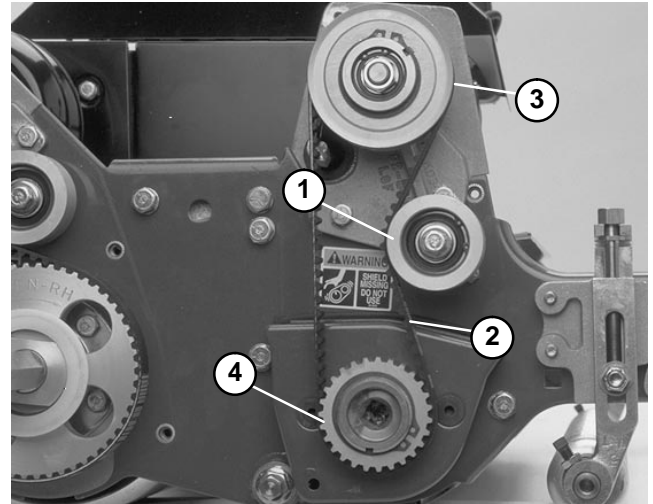

Figure 12

- | | |
|--------------------|------------------|
| 1. Idler pulley | 3. Clutch pulley |
| 2. Reel drive belt | 4. Drive pulley |

Reel Drive Idler Pulley and Bearing

Removal

1. Remove reel drive belt from the reel drive assembly (see Reel Drive Belt Replacement Removal).
2. Remove cap screw (2) and lock washer (47) from the pulley support spacer (58). Remove idler pulley assembly from the clutch housing (Fig. 11).

Disassembly (Fig. 13)

Note: The idler pulley assemblies for the reel drive and drum drive assemblies are identical.

1. Remove cap screw, lock washer, and flat washer from the pulley support spacer. Pull spacer from the idler pulley.
2. Remove snap ring. Pull ball bearing from the idler pulley.

Assembly (Fig. 13)

1. Press new ball bearing into the idler pulley. Press pulley support spacer into the ball bearing and idler pulley.
2. Install snap ring into idler pulley. Secure flat washer, lock washer, and cap screw into the pulley support spacer.

Installation

1. Make sure engine is OFF. Remove high tension lead from the spark plug. Park mower on a level surface.
 1. Position cap screw (2) with lock washer (47) into the clutch housing (1). Start cap screw into pulley support spacer (58) of the idler assembly until lock washer just starts to compress. **Do not over tighten (Fig. 11).**
2. Reinstall reel drive belt to the reel drive assembly (see Reel Drive Belt Installation).

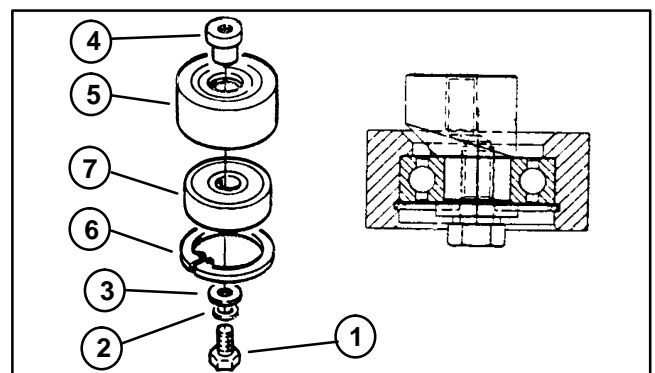

Figure 13

- | | |
|--------------------------|-----------------|
| 1. Cap screw | 5. Idler pulley |
| 2. Lock washer | 6. Snap ring |
| 3. Flat washer | 7. Ball bearing |
| 4. Pulley support spacer | |

Clutch Bearing

Removal

1. Remove reel drive belt from the reel drive assembly (see Reel Drive Belt Replacement Removal).
2. Remove clutch lever (24) as follows (Fig. 11):
 - A. Remove cap screw (27), lock washer (22), belle-ville washer (26), and spacer (25) from the clutch housing (1). Remove detent spring (20).
 - B. Work clutch boot (28) from the clutch housing. Pull clutch lever from the clutch housing.
 - C. Replace actuator pin (19) if necessary. Torque lock nut (21) from 45 to 60 in-lb (52 to 69 kg-cm).
3. Remove jam nut and lock washer from the power shaft. Pull clutch and pulley assembly from the shaft. Slide clutch jaw driver off the power shaft being careful not to lose the keys (Fig. 14).

IMPORTANT: Make sure both keys are removed from the power shaft prior to removing the clutch housing (Fig. 14).

4. Remove both cap screws (2) and lock nuts (3) securing the clutch housing (1) to the frame (Fig. 11). Slide clutch housing off the power shaft and away from the frame (Fig. 14).

Clutch Housing Disassembly (Fig. 11)

1. Remove retaining ring (8) from clutch housing (1).
2. Pull ball bearing (4) from the clutch housing (1). Remove wave washer (7); replace if damaged or worn.
3. Remove oil seal (6) from clutch housing (1).

Clutch Housing Assembly (Fig. 11)

1. Press new oil seal (6) into the clutch housing (1) on the grease fitting (5) side. **Flat side of seal must be out.**
2. Place wave washer (7) into clutch housing (1). With the seal side out, press new ball bearing (4) into the housing.
3. Install retaining ring (8) into the clutch housing (1).

Clutch and Pulley Disassembly (Fig. 15)

1. Remove large retaining ring securing the driver to the pulley. Pull the driver out of the pulley. Remove key.
2. Remove small retaining ring from the driver. Pull ball bearings from driver.

Clutch and Pulley Assembly (Fig. 15)

1. Press new ball bearings into driver. Secure bearings with small retaining ring.
2. Place key into the keyway of the driver. Press driver through the pulley enough to expose retaining ring groove.
3. Secure large retaining ring to the driver.

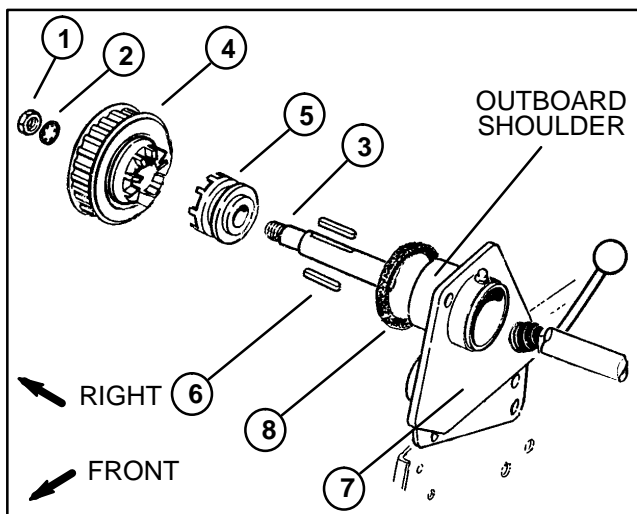

Figure 14

- | | |
|---------------------------|----------------------|
| 1. Jam nut | 5. Clutch jaw driver |
| 2. Lock washer | 6. Key |
| 3. Power shaft | 7. Clutch housing |
| 4. Clutch and pulley assy | 8. Felt seal |

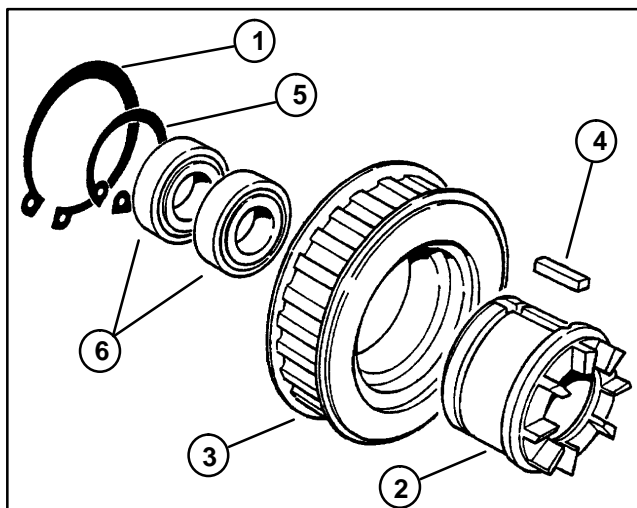

Figure 15

- | | |
|-------------------------|-------------------------|
| 1. Large retaining ring | 4. Key |
| 2. Driver | 5. Small retaining ring |
| 3. Pulley | 6. Ball bearing |

Installation

1. Park mower on a level surface. Make sure engine is OFF. Remove high tension lead from the spark plug.

2. If the felt seal is damaged or worn, replace seal as follows (Fig. 14):

A. Completely remove seal and adhesive from the out board shoulder of the clutch housing.

B. Apply 3M adhesive EC-1099 or equivalent to the outboard shoulder of the housing. Attach seal to housing.

C. Fill clutch housing about half full with No. 2 multi-purpose lithium base grease.

3. Slide clutch housing (1) onto the power shaft (9) with oil seal (6) towards the shaft. **Be careful not to damage the seal (Fig. 11).**

4. Place both cap screws (2) through the bearing housing (1) and frame. Secure cap screws with both lock nuts (3). **Make sure clutch housing fits tightly against the edge of the frame (Fig. 11).**

5. Tap both keys into the keyways of the power shaft. Apply Never Seize to the area of the keys and bearing journal of the clutch jaw driver (Fig. 14).

6. Place clutch jaw driver on the shaft with the jaws facing out. Align slots in the clutch jaw driver with the keys and slide into position (Fig. 14).

7. Place clutch and pulley assembly on the power shaft with the jaws facing the clutch jaw driver. Secure assembly to the shaft with the lock washer and jam nut (Fig. 14).

8. Place end of clutch lever (24) with actuator pin (19) through the clutch housing (1). Seat clutch boot (28) in the hole of the housing (Fig. 11).

9. Install clutch lever to the clutch housing (Fig. 16).

A. Place lock washer, belleville washer, and spacer on the cap screw. **Make sure concave side of belleville washer faces the clutch lever when installed.**

Note: On newer models, the detent spring is symmetrical. The spring can be installed in either direction.

B. Insert cap screw with the washers and spacer through the hole in the clutch lever. **Place detent spring on cap screw with the two small holes down and the hole closest to the edge away from the lever.**

C. With the actuator pin engaging in the groove of the clutch jaw driver (slide driver all the way into the housing), secure cap screw into the clutch housing (Fig. 14).

10. Make sure clutch engages and disengages with noticeable detent and without binding. It may be necessary to rotate the clutch pulley assembly (12) to achieve engagement (Fig. 11).

11. Reinstall reel drive belt to the reel drive assembly and adjust belt (see Reel Drive Belt Replacement Installation).

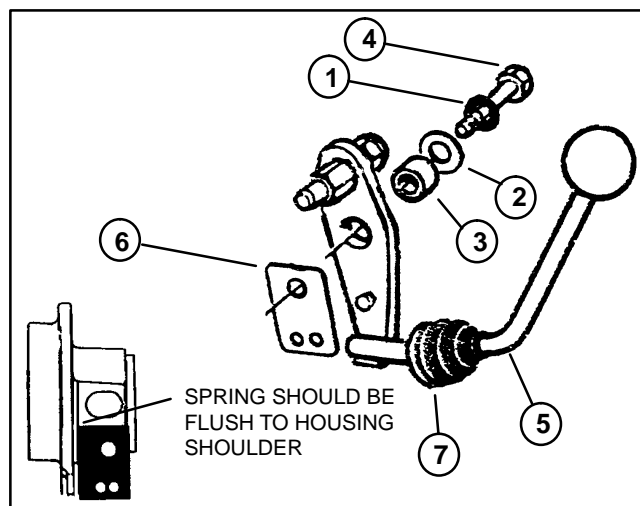

Figure 16

- | | |
|----------------------|------------------|
| 1. Lock washer | 5. Clutch lever |
| 2. Belleville washer | 6. Detent spring |
| 3. Spacer | 7. Clutch boot |
| 4. Cap screw | |

Drum Drive Assembly

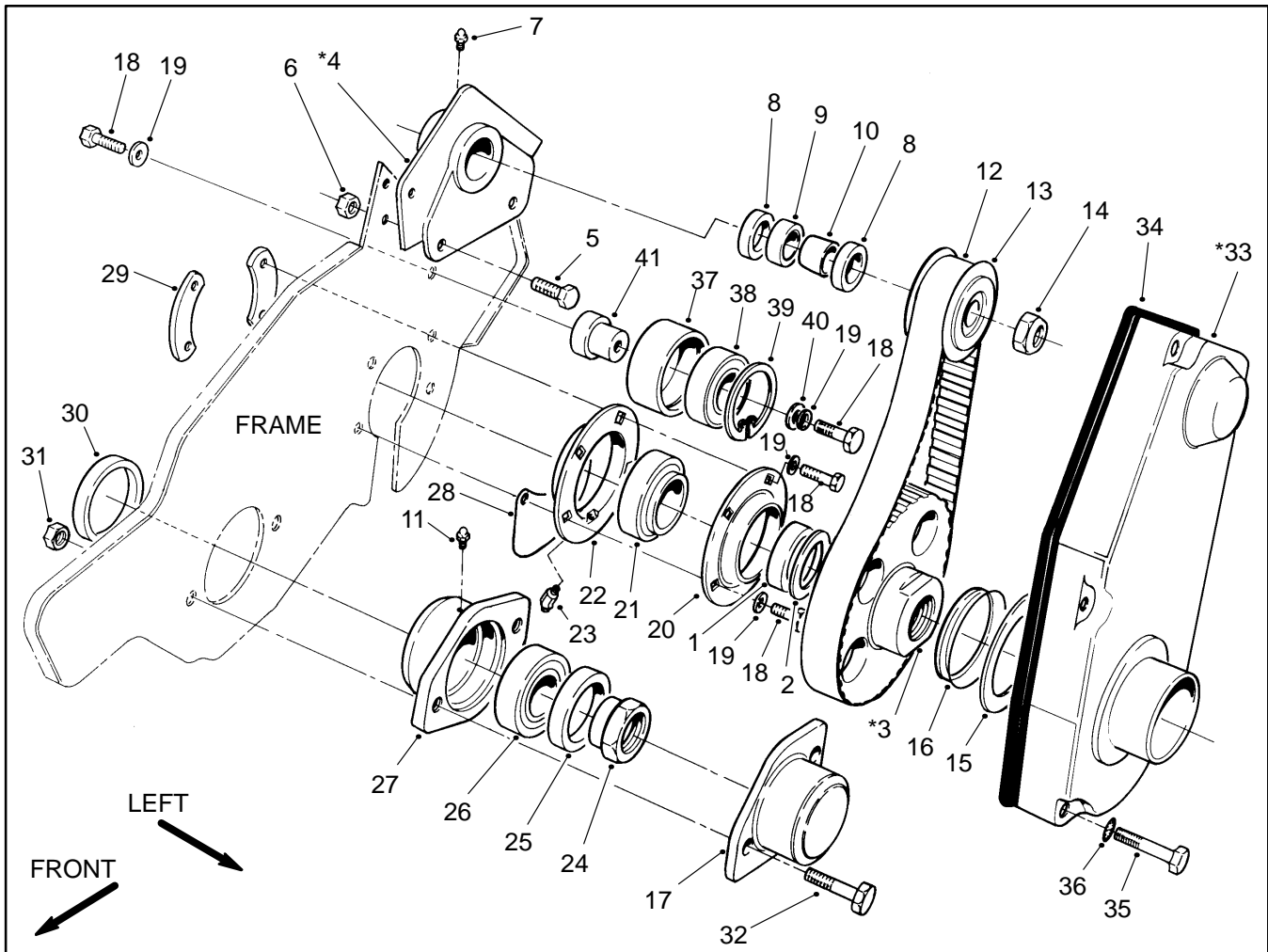

Figure 17

- | | | |
|--------------------|----------------------|--------------------------|
| 1. Spacer | 14. Nut | 29. Bearing clamp |
| 2. Backup washer | 15. Washer | 30. Seal |
| 3. Pulley (LH) | 16. V-ring seal | 31. Lock nut |
| * Pulley (RH) | 17. Bearing cover | 32. Cap screw |
| 4. Housing (LH) | 18. Cap screw | 33. Drum belt cover (LH) |
| * Housing (RH) | 19. Lock washer | * Drum belt cover (RH) |
| 5. Cap screw | 20. Flangette | 34. Seal strip |
| 6. Lock nut | 21. Bearing | 35. Cap screw |
| 7. Grease fitting | 22. Flangette | 36. Lock washer |
| 8. Seal | 23. Grease fitting | 37. Idler pulley |
| 9. Bearing | 24. Bearing lock nut | 38. Ball bearing |
| 10. Spacer | 25. Seal | 39. Snap ring |
| 11. Grease fitting | 26. Bearing | 40. Flat washer |
| 12. Belt | 27. Bearing housing | 41. Spacer |
| 13. Pulley | 28. Closure | |

Note: All parts are identical on both sides of the mower frame except as noted.

Drum Drive Belt Replacement

Removal

1. Park mower on a level surface. Make sure engine is OFF. Remove high tension lead from the spark plug.
2. Remove wheels if attached (see Wheels in the Service and Repairs section of Chapter 6 – Wheels and Accessories).
3. Remove cap screws (35), lock washers (36) and drum belt cover (33) to expose the belt (12) (Fig. 17).
4. Loosen cap screw (18) securing the spacer (41) (Fig. 17). Pivot the idler pulley away from the drive belt to loosen belt tension (Fig. 18).
5. Remove drum drive belt from both pulleys (Fig. 18).

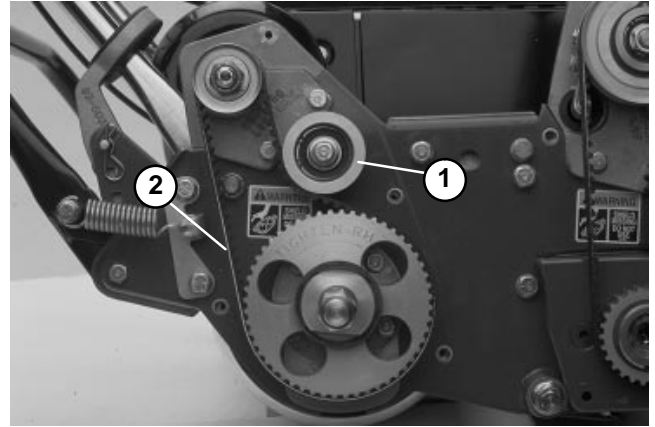

Figure 18

1. Idler pulley

2. Drum drive belt

Installation

1. Park mower on a level surface. Make sure engine is OFF. Remove high tension lead from the spark plug.
2. Place a new drum drive belt onto both pulleys (Fig. 18).
3. Adjust drum drive belt tension and reinstall drum belt cover (see Drum Drive Belt in the Adjustments section).
4. Replace both wheels if they were attached (see Wheels in the Service and Repairs section of Chapter 6 – Wheels and Accessories).

Drum Drive Idler Pulley and Bearing

Removal

1. Remove drum drive belt from the drum drive assembly (see Drum Drive Belt Replacement Removal).
2. Remove cap screw (18) and lock washer (19) from the spacer (41). Remove idler pulley assembly from the clutch housing (Fig. 17).

Disassembly and Reassembly

Note: The idler pulley assemblies for the drum drive reel drive assemblies are identical.

1. See Reel Drive Idler Pulley and Bearing Disassembly and Reassembly.

Installation

1. Park mower on a level surface. Make sure engine is OFF. Remove high tension lead from the spark plug.
2. Position cap screw (18) with lock washer (19) into the housing (4). Start cap screw into spacer (41) of the idler assembly until the lock washer just starts to compress. **Do not over tighten (Fig. 17).**
3. Reinstall drum drive belt to the drum drive assembly and adjust belt tension (see Drum Drive Belt Installation).

Differential Axle Pulley and Bearing

Removal

1. Remove drum drive belt from the drum drive assembly (see Drum Drive Belt Replacement Removal).
2. Remove nut from the differential axle. Remove pulley and woodruff key from the axle (Fig. 19).

Note: On the housing (RH), the hose clamp must be loosened and the differential boot must be removed from the housing before the housing can be removed from the frame and differential axle (Fig. 20).

3. Remove cap screw and lock nut from the housing and frame. Slide housing off of the differential axle (Fig. 19).

Disassembly (Fig. 21)

1. Remove spacer from housing and seal by. Replace if worn or damaged.
2. Remove both seals from the housing. Discard both seals and replace with new ones.
3. Pull bearing from housing and discard.

Assembly (Fig. 21)

1. Press seal with the flat side out into the housing side **opposite** the grease fitting.
2. Press bearing into housing.
3. Press a second seal with the flat side out into the grease fitting side of the housing

Installation (Fig. 19)

1. Park mower on a level surface. Make sure engine is OFF. Remove high tension lead from the spark plug.
2. Slide housing over the differential axle with the grease fitting towards the inboard side of the mower.
3. Secure housing to the frame with both cap screws and lock nuts.
4. On the housing (RH), attach the differential boot to the housing. Secure the hose clamp to the boot and housing (Fig. 20).
5. Slide spacer onto differential axle. Press spacer into seal until it contacts the inner race of the bearing.
6. Tap woodruff key into the key way of the differential axle. Apply never seize the axle in the area of the keys.

7. Slide pulley onto the differential axle while aligning pulley keyway with the woodruff key. Secure pulley to the axle with the nut.

8. Replace drum drive belt to the drum drive assembly and adjust belt tension (see Drum Drive Belt Replacement Installation).

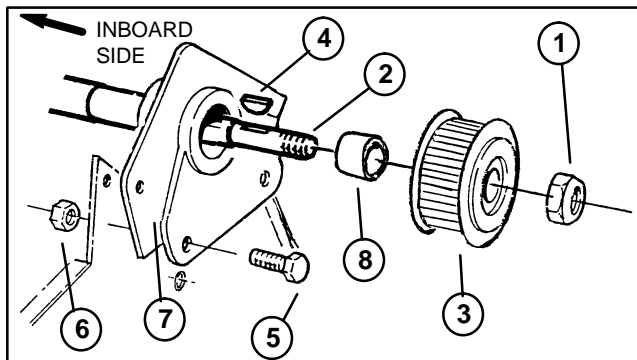

Figure 19

- | | |
|----------------------|--------------|
| 1. Nut | 5. Cap screw |
| 2. Differential axle | 6. Lock nut |
| 3. Pulley | 7. Housing |
| 4. Woodruff key | 8. Spacer |

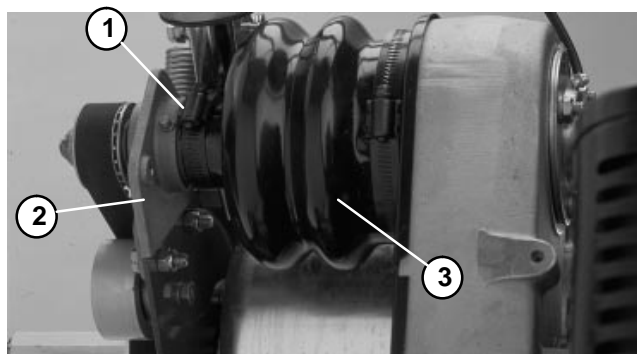

Figure 20

- | | |
|-----------------|----------------------|
| 1. Hose clamp | 3. Differential boot |
| 2. Housing (RH) | |

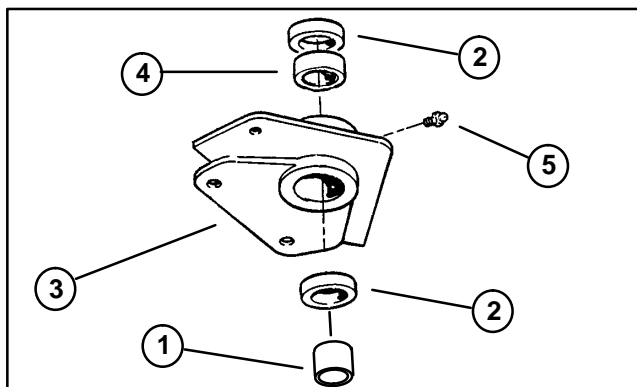

Figure 21

- | | |
|------------|-------------------|
| 1. Spacer | 4. Bearing |
| 2. Seal | 5. Grease fitting |
| 3. Housing | |

Drum Shaft Bearing

Removal

1. Remove drum drive belt from the drum drive assembly (see Drum Drive Belt Replacement Removal).

Note: The pulley (LH) has left hand threads, while the pulley (RH) has right hand threads. Each pulley has an arrow stamped on it for the direction of tightening.

2. Remove pulley from drum shaft as follows (Fig. 22):

A. Use a suitable wrench on the flats of the drum shaft, between the drum and the frame, to lock the shaft.

B. Unscrew pulley from the drum shaft.

C. Remove backup washer and spacer from the drum shaft.

3. Remove bearing from drum shaft and frame as follows (Fig. 23):

A. Remove four cap screws and lock washers from the flangettes, closure, frame, and bearing clamp.

B. Pull closure and flangettes with the bearing from the frame and drum shaft.

C. Remove bearing from flangettes.

Installation

1. Park mower on a level surface. Make sure engine is OFF. Remove high tension lead from the spark plug.

2. Install bearing to the drum shaft and frame as follows (Fig. 23):

A. Place bearing between flangettes with the collar on the bearing towards the flangette **without** the grease fitting.

B. Insert two cap screws with lock washers through the bottom holes of the flangettes. Place closure onto capscrews. Secure assembly to frame with bearing clamps.

C. Secure remaining cap screws with lock washers through the flangettes and to the bearing clamps.

3. Install pulley to the drum shaft as follows (Fig. 22):

A. Apply loctite to the threads of the drum shaft.

B. Slide spacer and backup washer onto drum shaft.

C. Use a suitable wrench on the flats of the drum shaft, between the drum and the frame, to lock the shaft. Screw pulley to the drum shaft.

4. Install drum drive belt to the drum drive assembly (see Drum Drive Belt Replacement Installation).

5. Level drum to the reel (see Level Drum to Reel in the Adjustments section of Chapter 7– Cutting Unit).

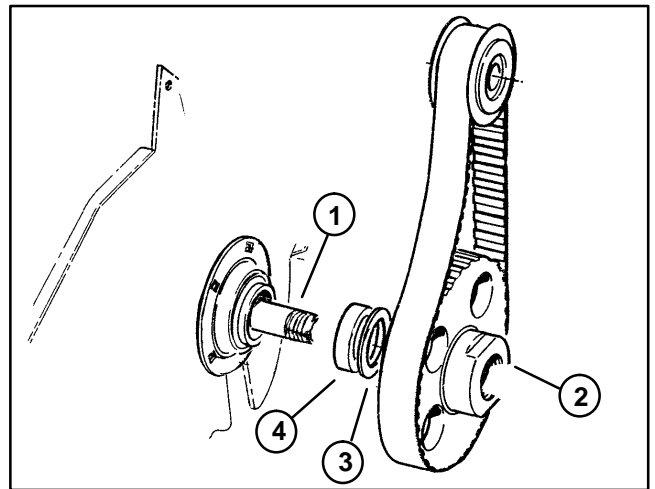

Figure 22

- | | |
|---------------|------------------|
| 1. Drum shaft | 3. Backup washer |
| 2. Pulley | 4. Spacer |

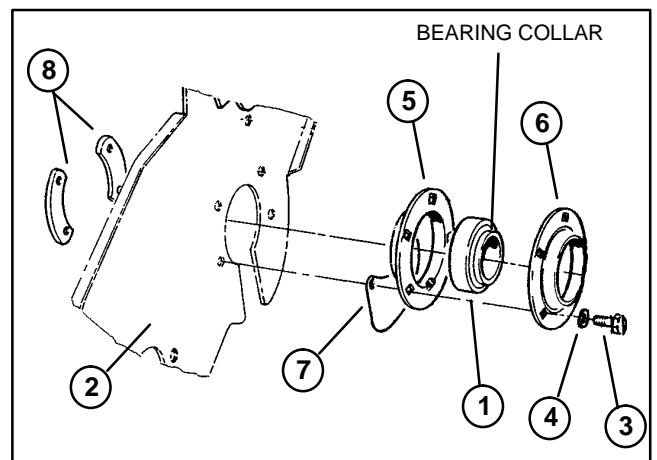

Figure 23

- | | |
|-----------------|-----------------------------|
| 1. Bearing | 5. Flangette |
| 2. Frame | 6. Flangette (w/grease ftg) |
| 3. Cap screws | 7. Closure |
| 4. Lock washers | 8. Bearing clamp |

Drum Assembly with Bearings (Models 04050, 04052–60000 & Up, and 04060)

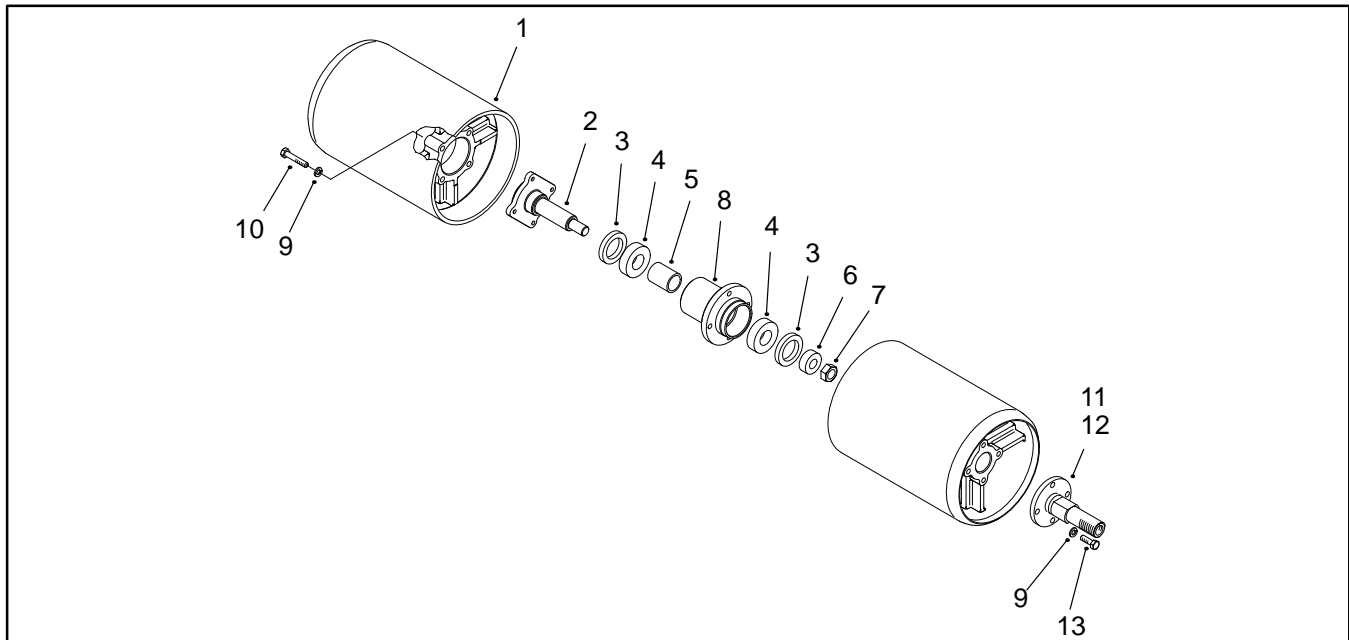

Figure 24

- | | | |
|--------------------|----------------|---------------------|
| 1. Drum | 6. Seal spacer | 10. Cap screw |
| 2. Drum spindle | 7. Lock nut | 11. Drum shaft (LH) |
| 3. Spring lip seal | 8. Drum hub | 12. Drum shaft (RH) |
| 4. Bearing | 9. Lock washer | 13. Cap screw |
| 5. Bearing spacer | | |

Removal

1. Remove both drum shaft bearings from both drum shafts (see Drum Shaft Bearing Removal).
2. Pivot mower back and remove drum assembly from the mower.

Disassembly

1. Remove four cap screws, lock washers, and drum shafts from each drum.
2. Remove cap screws and lock washers securing the drum spindle and drum hub to their respective drums. Remove spindle and hub assembly from both drums.
3. Remove lock nut and seal spacer from the drum spindle. Carefully slide drum spindle out of the drum hub bearings.
4. Remove both spring lip seals from the drum hub. Pull both bearings from the hub. Remove bearing spacer from the hub.

Assembly

Note: The seal side of each bearing should face the inside of the drum hub (Fig. 25).

1. Press bearing into the drum hub. Pack bearing with grease. Fill space outside of bearing with grease. Press spring lip seal into the hub with its flat side out (Fig. 25).
2. Insert seal spacer into drum hub. Press bearing into the hub and pack with grease. Fill space outside of the bearing with grease. Press second spring lip seal into the hub with its flat side out (Fig. 25).

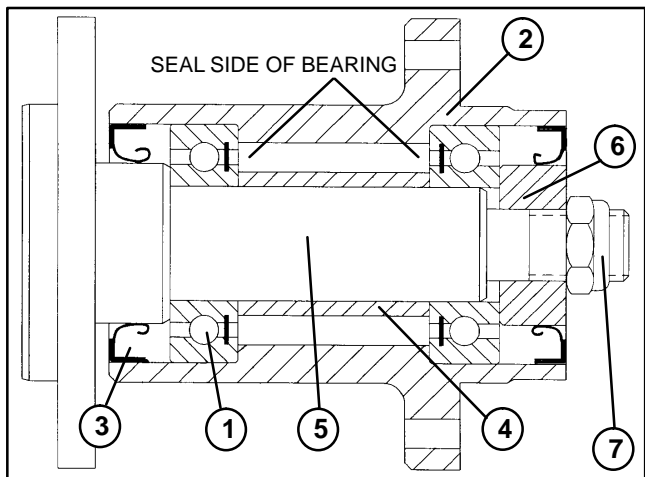

Figure 25

- | | |
|--------------------|-----------------|
| 1. Bearing | 5. Drum spindle |
| 2. Drum hub | 6. Seal spacer |
| 3. Spring lip seal | 7. Lock nut |
| 4. Bearing spacer | |

Note: The lock nut turns hard on the spindle shaft when tightened. Make sure all rotation has stopped when tightening. A good solid sound indicates the nut is tight.

3. Apply grease to the shaft of the drum spindle. Carefully slide drum spindle into drum hub bearings. Secure lock nut and seal spacer to the drum spindle (Fig. 25).

Note: The fit between the drum hub and drum is a close tolerance and can be easily jammed. The hub can be rotated when seated properly in the bore of the drum.

4. Secure drum hub to the drum with four cap screws and lock washers. Tighten screws using an alternating pattern. Repeat tightening sequence a second time.

5. Secure drum spindle to the drum with four cap screws and lock washers. Tighten screws using an alternating pattern. Repeat tightening sequence a second time.

6. Secure drum shaft to each drum with four cap screws and lock washers. Make sure shafts are seated properly. Tighten screws using an alternating pattern.

Installation

1. Park mower on a level surface. Make sure engine is OFF. Remove high tension lead from the spark plug.

2. Pivot mower back and position drum assembly under the mower to accept drum shaft bearings. Pivot mower back down.

3. Replace both drum shaft bearings to both drum shafts (see Drum Shaft Bearing Installation).

Drum Assembly with Bushings (Models 04051 and 04052–50001 to 59999)

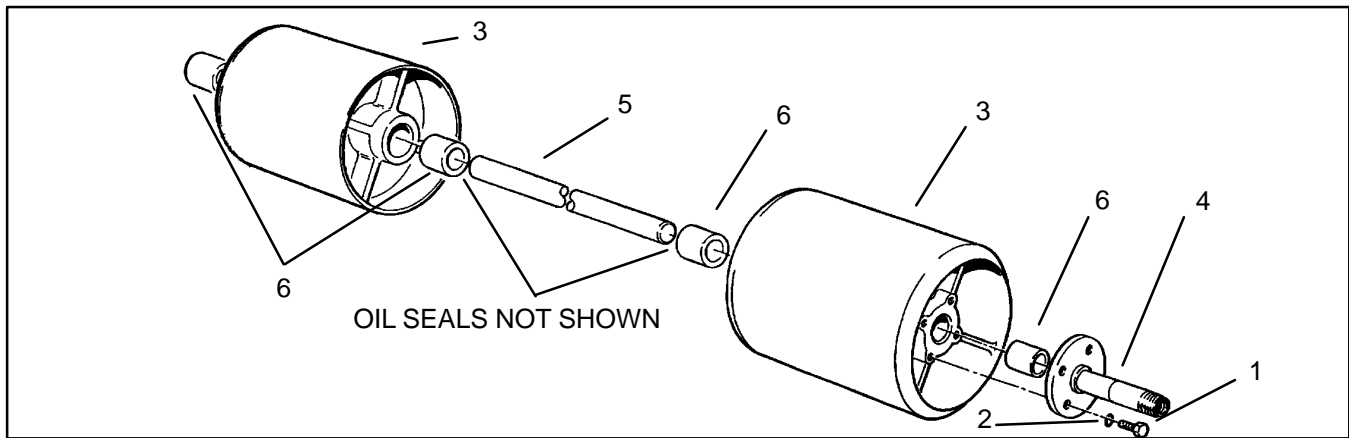

Figure 26

- | | | |
|----------------|--------------------------|---------------|
| 1. Cap screw | 3. Drum | 5. Drum shaft |
| 2. Lock washer | 4. Drum shaft extensions | 6. Bushing |

Removal

1. Remove both drum shaft bearings from both drum shafts (see Drum Shaft Bearing Removal).
2. Pivot mower back and remove drum assembly from the mower.

Disassembly

1. Remove four cap screws and lock washers from each drum. Remove both drum shafts extensions from each drum (Fig. 26).

2. Pull both drums apart and remove drum shaft from the drum (Fig. 26).

3. Remove bushings from the drum (Fig. 27).

- A. Insert bushing driver against the bushing.
- B. Drive bushing out of the drum by striking the end of the bushing driver with a hammer.
- C. Repeat Step B to remove the bushing and seal from the other end of the drum

4. Install outer bushing into the drum (Fig. 28 and 29).

- A. Install adapter sleeve onto the bushing driver so the counterbore of the sleeve is facing the bushing.
- B. Install a new bushing on the bushing driver, then secure pilot to the bushing and adapter sleeve.
- C. Insert pilot into the bushing bore of the drum. Install bushing until the adapter sleeve meets the drum.

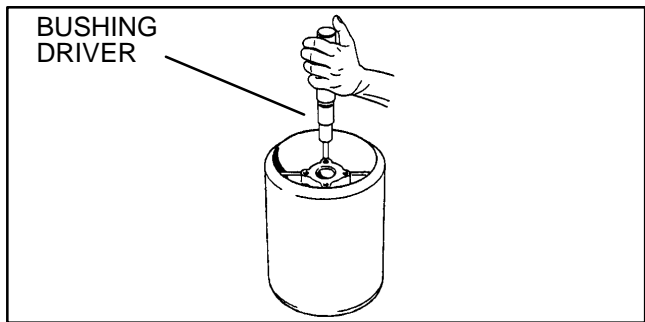

Figure 27

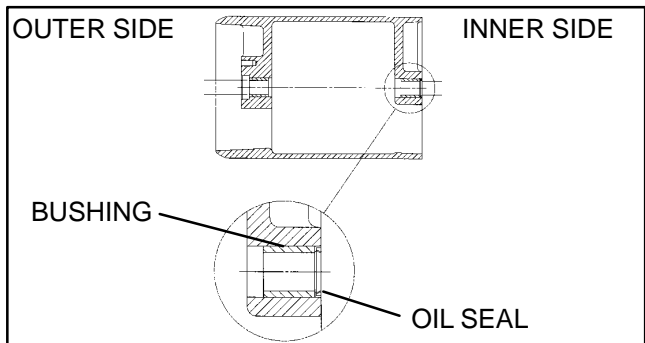

Figure 28

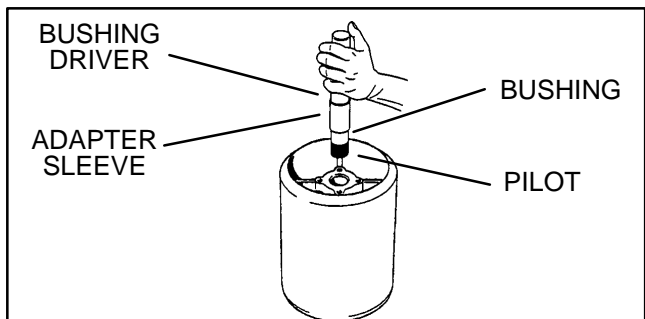

Figure 29

5. Install inner bushing into drum (Fig. 30).

Note: The setting of the adapter sleeve is critical so the bushing is inserted deep enough for oil seal installation.

A. Install adapter sleeve on the bushing driver so the counterbore of the sleeve seats $\frac{3}{16}$ inch (0.48 cm) beyond the step on the driver.

B. Install a new bushing on the bushing driver, then secure pilot to the bushing and adapter sleeve.

C. Insert pilot into the bushing bore of the drum. Install bushing until the adapter sleeve meets the drum.

6. Size bushing with reamer (Fig. 31).

Note: Size only one bushing at a time.

A. Attach reamer to a T-handle.

B. Size bushing with reamer being careful to keep the reamer square with the drum race.

C. Clean inside bushing so it is free of debris.

7. Install oil seal into drum (Fig. 32 and 28).

A. Install adapter sleeve on the bushing driver so the counterbore on the sleeve will be facing the oil seal.

B. Place an oil seal on the bushing driver. Install oil seal with the driver until the adapter sleeve contacts the drum.

Installation

1. Park mower on a level surface. Make sure engine is OFF. Remove high tension lead from the spark plug.

2. Pivot mower back and position drum assembly under the mower to accept drum shaft bearings. Pivot mower back down.

3. Reinstall both drum shaft bearings to both drum shafts (see Drum Shaft Bearing Installation).

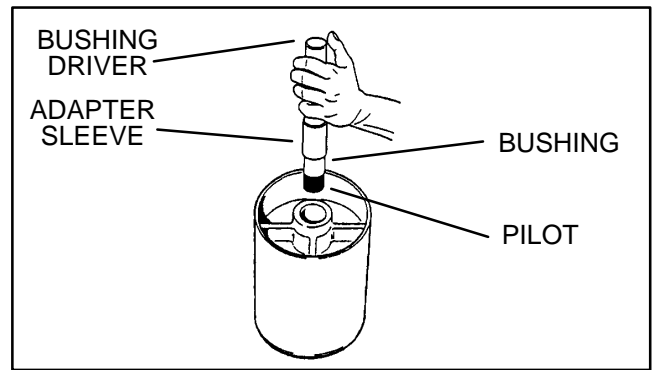

Figure 30

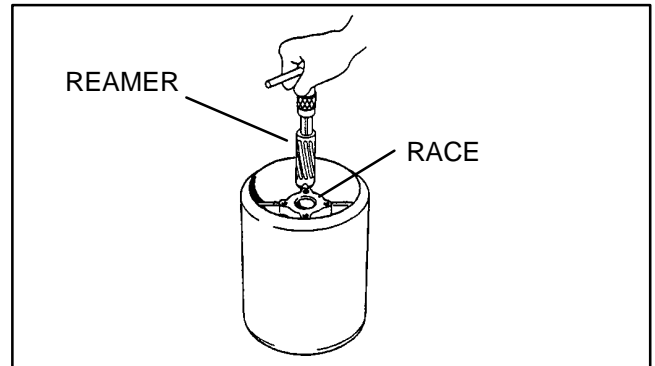

Figure 31

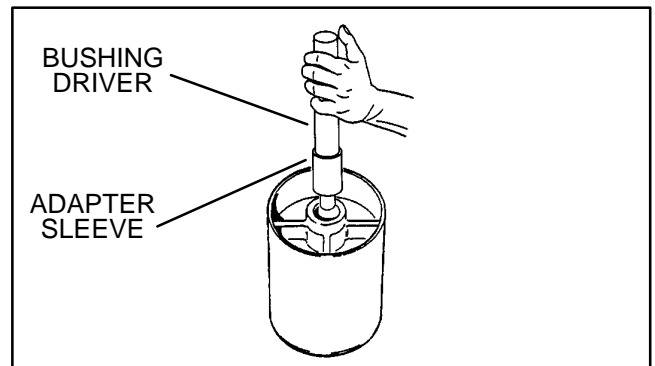

Figure 32

Counter Shaft Assembly

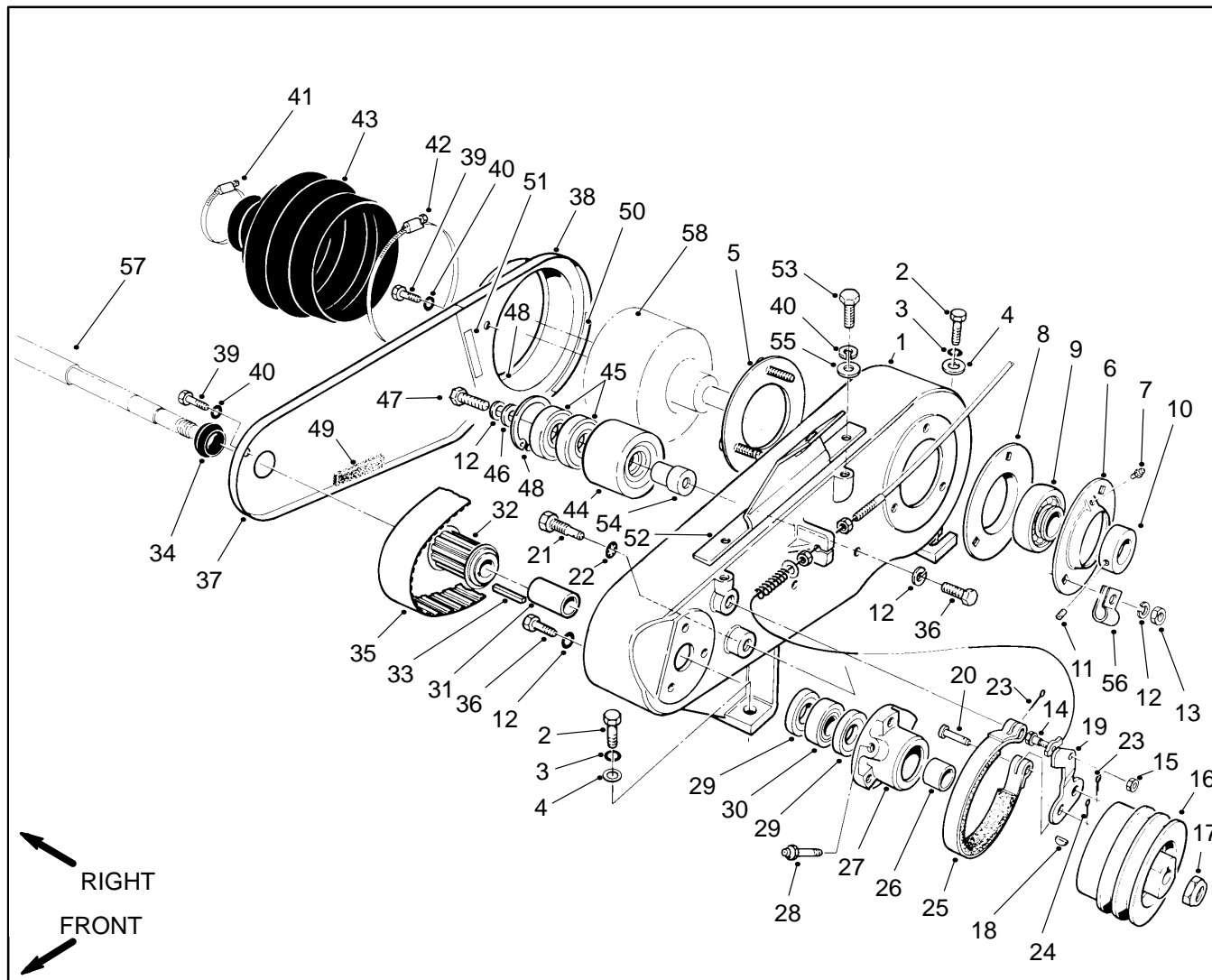

Figure 33

- | | | |
|-------------------------|-------------------------|------------------------------------|
| 1. Countershaft housing | 21. Brake support | 40. Lock washer |
| 2. Cap screw | 22. Lock washer | 41. Hose clamp |
| 3. Lock washer | 23. Cotter pin | 42. Hose clamp |
| 4. Flat washer | 24. Cotter pin | 43. Differential boot |
| 5. Screw plate | 25. Brake band | 44. Idler pulley |
| 6. Flangette | 26. Short spacer | 45. Ball bearing |
| 7. Grease fitting | 27. Bearing housing | 46. Flat washer |
| 8. Flangette | 28. Grease fitting | 47. Cap screw |
| 9. Bearing | 29. Seal | 48. Retaining ring |
| 10. Locking collar | 30. Bearing | 49. Cover seal strip |
| 11. Set screw | 31. Long Spacer | 50. Cover seal strip |
| 12. Lock washer | 32. Countershaft pulley | 51. Cover seal strip |
| 13. Jam nut | 33. Key | 52. Cover bracket |
| 14. Shoulder bolt | 34. Countershaft seal | 53. Cap screw |
| 15. Lock nut | 35. Belt | 54. Spacer |
| 16. Input shaft pulley | 36. Cap screw | 55. Flat washer |
| 17. Lock nut | 37. Front box cover | 56. Clip |
| 18. Key | 38. Rear box cover | 57. Power shaft |
| 19. Brake lever | 39. Cap screw | 58. Differential assembly & pulley |
| 20. Clevis pin | | |

Brake Band Replacement

Removal

1. Park mower on a level surface. Make sure engine is OFF. Remove high tension lead from the spark plug.
2. Remove interference to brake band (Fig. 34).
 - A. Remove bellcrank cover by removing both cap screws and lock washers.
 - B. Remove belt shield by removing both cap screws and lock washers.
 - C. Disengage clutch and remove both V-belts.
3. Disengage brake to allow removal of brake band.
4. Remove lock nut (17) from power shaft (57). Slide input shaft pulley (16) off the shaft. Remove key (18) from the shaft (Fig. 33).
5. Remove brake band (25) from counter shaft housing (1) as follows (Fig. 33).
 - A. Remove cotter pin (23) from the brake support (21).
 - B. Remove cotter pin (24) and clevis pin (20) from the brake lever (19).
 - C. Remove the brake band from the brake support and brake lever.

6. Reinstall interference previously removed (Fig. 34).
 - A. Make sure clutch is disengaged. Install both V-belts.
 - B. Secure belt shield to engine block with both cap screws and lock washers. **Do not over tighten.**
 - C. Secure bellcrank cover to counter shaft housing with both cap screws and lock washers. **Do not over tighten.**

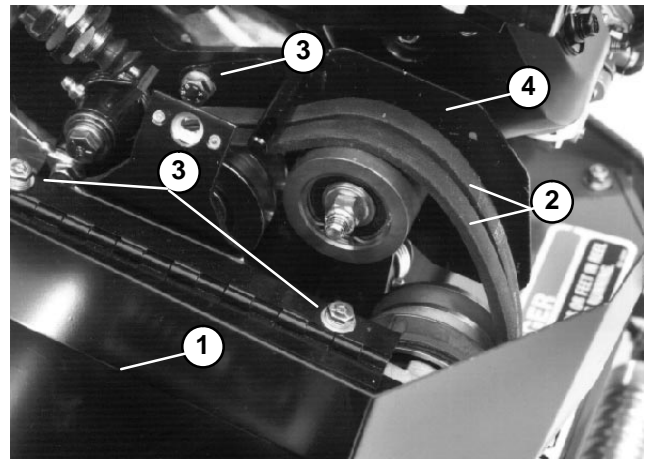

Figure 34

- | | |
|---------------------|----------------|
| 1. Bell crank cover | 3. Cap screw |
| 2. V-belts | 4. Belt shield |

Installation

1. Park mower on a level surface. Make sure engine is OFF. Remove high tension lead from the spark plug.
2. Disengage brake to allow installation of brake band.
3. Attach new brake band to the counter shaft housing as follows (Fig. 35).

Note: Make sure both cotter pins are locked so there is no contact between the input shaft pulley and cotter pins.

- A. Secure lower eye of brake band to the brake lever with the clevis pin and cotter pin. Lock cotter pin.
 - B. Secure upper eye of the brake band to the brake support with cotter pin. Lock cotter pin.
4. Apply never seize to the keyway area of the power shaft (57). Install key (18) to the shaft (Fig. 33).
 5. Slide input shaft pulley (16) onto the power shaft (57) and through the brake band (25). Secure pulley to the power shaft with lock nut (17) (Fig. 33 and 35).

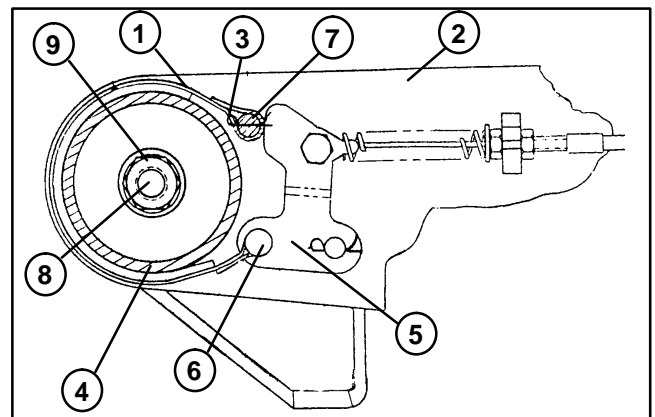

Figure 35

- | | |
|--------------------------|------------------|
| 1. Brake band | 6. Clevis pin |
| 2. Counter shaft housing | 7. Brake support |
| 3. Cotter pin | 8. Power shaft |
| 4. Input shaft pulley | 9. Lock nut |
| 5. Brake lever | |

Power Shaft Bearing

Removal

1. Remove brake band from the counter shaft housing (see Brake Band Removal)
2. Remove cap screw (39) and lock washer (40) from the front box cover (37) and counter shaft housing (1). Remove cover from housing (Fig. 33).
3. Loosen cap screw (36) enough to rotate idler pulley (44) away from the belt (35). Loosen belt by rotating the idler pulley counterclockwise (Fig. 33).
4. Remove three cap screws (36) and lock washers (12) from the counter shaft housing (1) and bearing housing (27). Slide the bearing housing off the power shaft (57) (Fig. 33).

Disassembly (Fig. 36)

1. Pull short spacer from the inner seal and bearing housing.
2. Pull outer seal, bearing, and inner seal from the bearing housing.

Assembly (Fig. 36)

1. Press new seal with its flat side up through the flange side of the bearing housing.
2. Press new bearing into the flange side of the bearing housing.
3. Press second new seal with its flat side up through the flange side of the bearing housing.
4. Push short spacer through inner seal until it contacts the inner race of the bearing.

Installation

1. Park mower on a level surface. Make sure engine is OFF. Remove high tension lead from the spark plug.
2. Slide the bearing housing onto the power shaft (57).
3. Secure three cap screws (36) and lock washers (12) through the counter shaft housing (1) and into the bearing housing (27) (Fig. 33).
4. Adjust idler pulley and differential belt tension. Reinstall front box cover (see Differential Belt in the Adjustments section).
5. Reinstall brake band to the counter shaft housing (see Brake Band Replacement Installation).

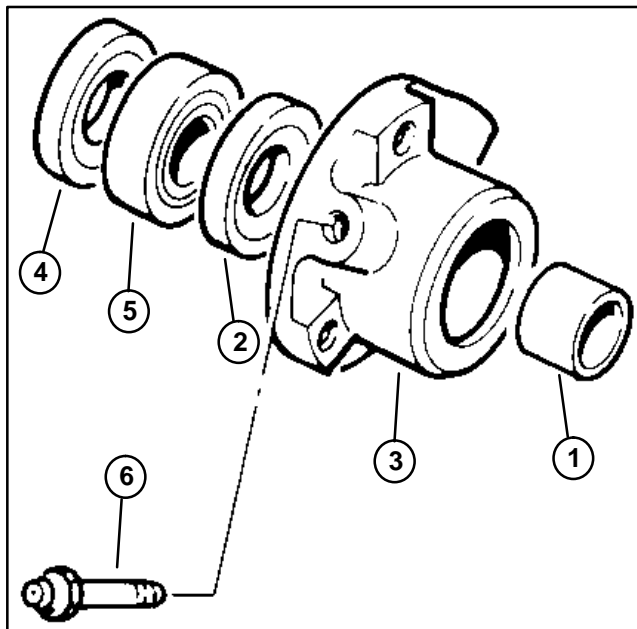

Figure 36

- | | |
|--------------------|-------------------|
| 1. Short spacer | 4. Outer seal |
| 2. Inner seal | 5. Bearing |
| 3. Bearing housing | 6. Grease fitting |

Differential Axle Bearing (Countershaft Housing)

Removal

1. Park mower on a level surface. Make sure engine is OFF. Remove high tension lead from the spark plug.
2. Lower handle to allow a clearance for the removal of the bearing and flangettes from the differential axle (see Handle in the Adjustments section of Chapter 6 – Wheels and Accessories).

Note: The locking collar securing the left differential axle to the countershaft housing is a eccentric flange type.

3. Loosen the set screw on the locking collar. Unlock collar by striking it with a punch in the clockwise direction (Fig. 38).
4. Remove bearing housing on the side plate for the **left** differential axle (see Differential Axle Pulley and Bearing Removal).
5. Slide locking collar off the differential axle.
6. Remove jam nuts (13), lock washers (12), and cable clip (15) from the studs of screw plate (5) (Fig. 33).

IMPORTANT: Before removing the flangettes and bearing from the differential housing, support the axle in its original position to prevent possible damage to the remaining differential axle bearing.

7. Slide flangettes (6 and 8) and bearing (9) of the differential axle (Fig. 33).

Installation

1. Park mower on a level surface. Make sure engine is OFF. Remove high tension lead from the spark plug.
2. Stack flangette (8), bearing (9), and flangette (6) together. Make sure lock collar on the bearing is positioned towards the flangette with the grease fitting (7) (Fig. 33).

Note: Before tightening jam nuts (13), make sure that the differential axles turn freely and are aligned (Fig. 33).

3. Slide flangettes (6 and 8) and bearing (9) over the differential axle. Secure assembly and cable clip (15) to the studs of screw plate (5) with the jam nuts (13) and lock washers (12) (Fig. 33).
4. Slide collar onto the differential axle. Lock collar by striking it with a punch in the counterclockwise direction. Tighten set screw on the locking collar (Fig. 38).
5. Reinstall bearing housing for the **left** differential axle (see Differential Axle Pulley and Bearing).

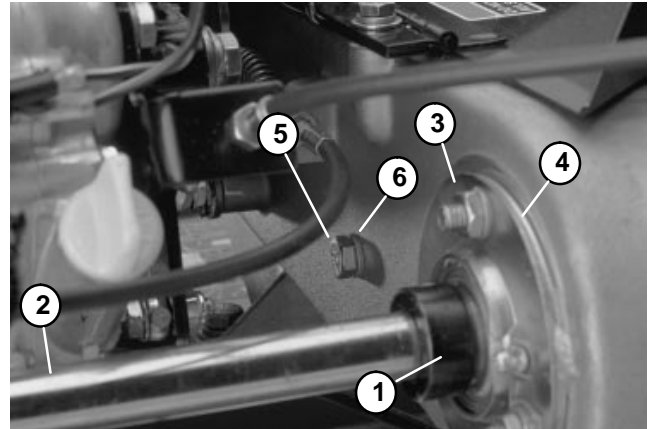

Figure 37

- | | |
|---------------------------|----------------|
| 1. Locking collar | 4. Flangettes |
| 2. Differential axle (LH) | 5. Cap screw |
| 3. Jam nut & lock washer | 6. Lock washer |

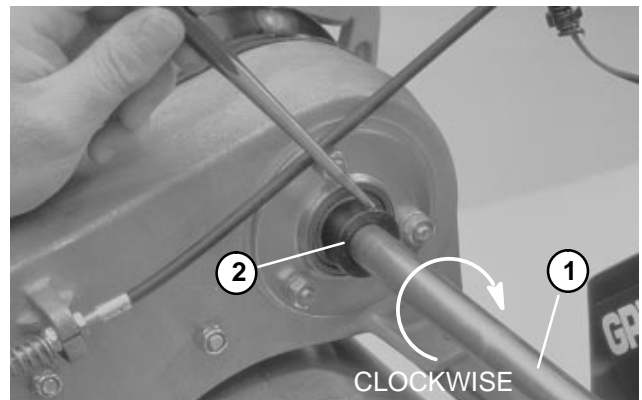

Figure 38

- | | |
|---------------------------|-------------------|
| 1. Differential axle (LH) | 2. Locking collar |
|---------------------------|-------------------|

Differential Idler and Bearing

Removal

1. Park mower on a level surface. Make sure engine is OFF. Remove high tension lead from the spark plug.
2. Remove capscrews (39) and lock washers (40) securing rear and front box covers (38 and 39) to the countershaft housing (1). Pull covers from housing (Fig. 33).
3. Remove cap screw and lock washer that secure the idler pulley (Fig. 37). Remove idler pulley from countershaft housing (Fig. 39).

Disassembly (Fig 33)

1. Remove cap screw (47), lock washer (12), and flat washer (46) from the spacer (54). Remove retaining ring (48) from the pulley (44).
2. Press spacer (54) out of the pulley (44). Press bearings (45) out of the pulley.

Assembly (Fig 33)

1. Press bearings (45) into the pulley (44). Press spacer (54) into the pulley.
2. Install retaining ring (48) into the pulley (44). Secure cap screw (47), lock washer (12), and flat washer (46) into the spacer (54).

Installation

1. Park mower on a level surface. Make sure engine is OFF. Remove high tension lead from the spark plug.
2. Reinstall idler pulley to the countershaft housing (Fig. 39). Secure idler pulley with cap screw and lock washer. Tighten cap screw until washer just starts to compress. Spacer must be free to rotate (Fig. 37).
3. Adjust differential belt tension and reinstall front and rear box covers (see Differential Belt Adjustment).

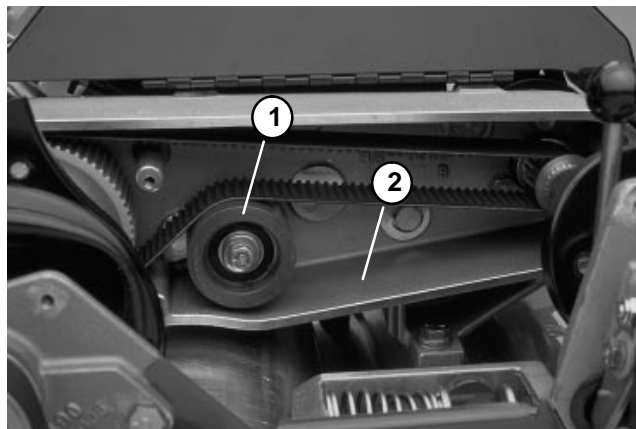

Figure 39

1. Idler pulley

2. Countershaft housing

Differential Assembly and Pulley

Removal

1. Park mower on a level surface. Make sure engine is OFF. Remove high tension lead from the spark plug.
2. Lower handle to allow clearances for the removal of the bearing and flangettes from the differential axle and the differential assembly from the countershaft housing (see Handle in the Adjustments section of Chapter 6 – Wheels and Accessories).
3. Remove capscrews (39) and lock washers (40) securing rear and front box covers (38 and 39) to the countershaft housing (1). Pull covers from housing (Fig. 33).
4. Loosen cap screw securing the idler to the counter shaft housing (Fig. 37). Pivot idler pulley counterclockwise away from the backside of belt to release belt tension (Fig. 39).

Note: The locking collar securing the left differential axle to the countershaft housing is a eccentric flange type.

5. Loosen the set screw on the locking collar. Unlock collar by striking it with a punch in the clockwise direction (Fig. 38).
6. Remove bearing housing for the **left** differential axle (see Differential Axle Pulley and Bearing Removal).

IMPORTANT: For the remainder of this procedure, support the axle in its original position to prevent possible damage to the differential axle bearing and differential housing bearing.

7. Remove bearing housing for the **right** differential axle (see Differential Axle Pulley and Bearing Removal).
8. Remove differential boot (43) and rear box cover (38) from the countershaft housing (1) and differential axle (Fig. 33).
9. Remove jam nuts, lock washers, and cable clip from the studs of screw plate. Slide locking collar and flangettes with the bearing off the differential axle. This step allows the differential assembly to be positioned for clearing the frame (Fig. 40).
10. Pull differential assembly out and up from the countershaft housing.
11. Remove lock nuts and flat washers from the differential assembly and pulley. Slide pulley clear of threads and differential axle (Fig. 42).

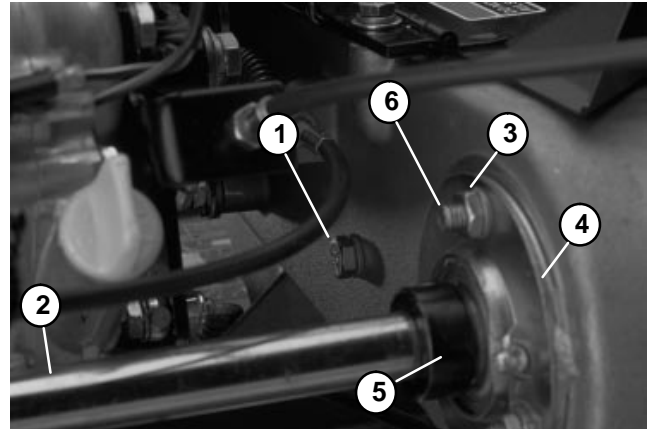

Figure 40

- | | |
|----------------------------|---------------------|
| 1. Cap screw & lock washer | 4. Flangettes |
| 2. Differential axle | 5. Locking collar |
| 3. Jam nut & lock washer | 6. Screw plate stud |

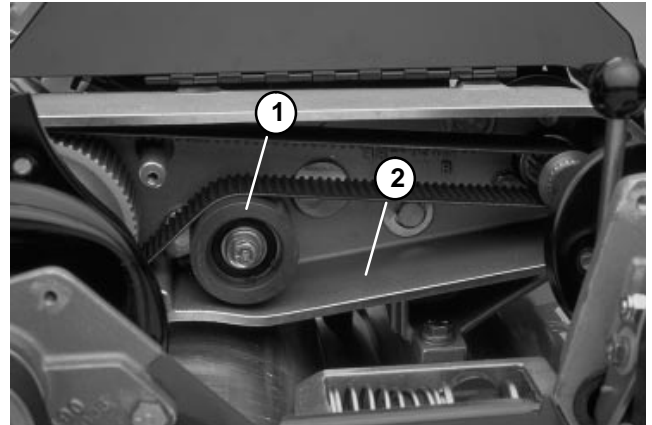

Figure 41

- | | |
|-----------------|-------------------------|
| 1. Idler pulley | 2. Countershaft housing |
|-----------------|-------------------------|

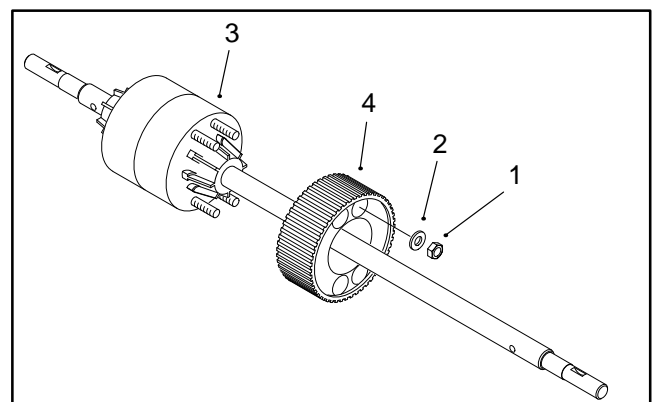

Figure 42

- | | |
|----------------|--------------------------|
| 1. Lock nut | 3. Differential assembly |
| 2. Flat washer | 4. Differential pulley |

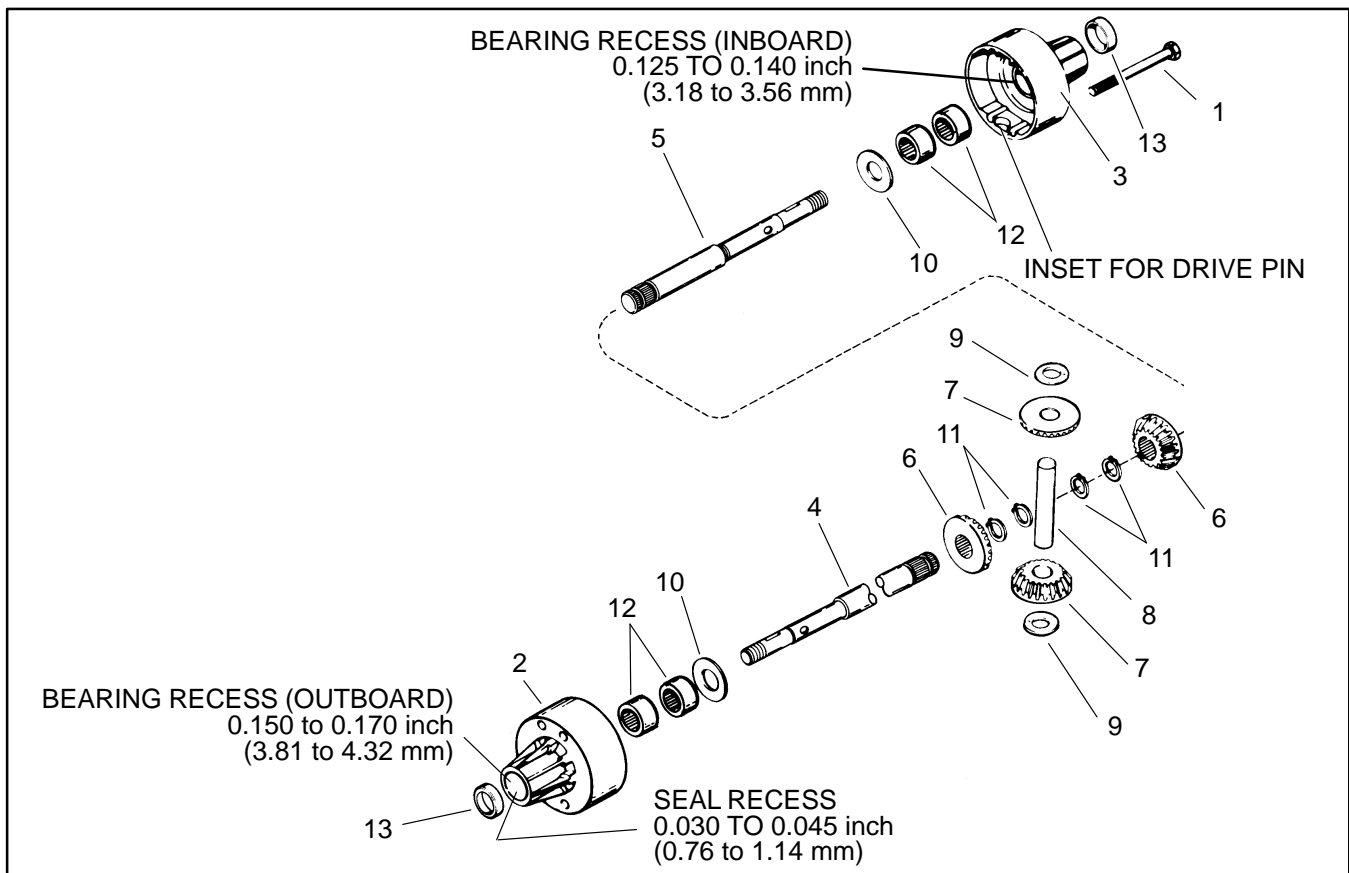

Figure 43

- | | | |
|---------------------------------|------------------|--------------------|
| 1. Flanged hex head screw | 6. Bevel gear | 10. Washer |
| 2. Differential carrier housing | 7. Pinion | 11. Retaining ring |
| 3. Differential carrier housing | 8. Drive pin | 12. Needle bearing |
| 4. Axle (long) | 9. Thrust washer | 13. Oil seal |
| 5. Axle (short) | | |

Note: Individual parts to the differential assembly can be obtained from your local Peerless Dealer/Distributor.

Disassembly (Fig. 43)

1. Clean outside of the differential assembly. Make sure keys are removed from the axles. Remove all burrs from the keyways and holes of the axles.
2. Remove four flanged hex head screws from the differential carrier housings. Separate both housings being careful not to drop the drive pin and pinion gears.
3. Pull each differential carrier housing from its axle and remove washer.
4. Remove both retaining rings from each axle. Separate the bevel gears from each axle.

Note: The differential carrier housings come assembled with both bearings and oil seal. It **may** be more economical to replace the both housings rather than repair them. If the needle bearings are damaged, it is recommended to replace all bearings in each housing.

5. If needle bearings are damaged, press both bearings and oil seal out of each differential carrier housing.

6. Remove both thrust washers and bevel gears from the drive pin.

7. Clean all parts so they are free of dirt and debris. Replace any worn, chipped, bent, or cracked parts.

Assembly (Fig. 43)

1. If needle bearings are being replaced, press both new bearings and new oil seal into each differential carrier housing as follows:
 - A. Press bearing into the inboard side of the of each housing. The bearing should be recessed 0.125 to 0.140 inch (3.18 to 3.56 mm).
 - B. Press bearing into the outboard side of the of each housing. The bearing should be recessed 0.150 to 0.170 inch (3.81 to 4.32 mm).
 - C. Press oil seal into the outboard side of the of each housing. The oil seal should be recessed 0.030 to 0.045 inch (0.76 to 1.14 mm).
 - D. Pack all bearings with molybdenum disulfide grease.

Note: If any of the bevel or pinion gears need to be replaced, it is recommended to replace all four gears as a complete set.

2. Attach bevel gears to the axles. Lock each gear in place with both retaining rings. Make sure flat side of retaining rings are away from the gear (Fig. 44).

3. Coat both washers with molybdenum disulfide grease. Slide each washer onto an axle (Fig. 44).

4. Slide the long axle through the needle bearings of the differential carrier housing with the four threaded holes. Thoroughly coat the bevel gear with molybdenum disulfide grease. Make sure the gear back is flush against the washer and housing inside face (Fig. 44).

5. Slide the short axle through the needle bearings of the other differential carrier housing. Thoroughly coat the bevel gear with molybdenum disulfide grease. Make sure the gear back is flush against the washer and housing inside face (Fig. 44).

6. Slide both pinion gears to the drive pin. Attach both thrust washers to the drive pin. Make sure both ends of the drive pin are exposed. Thoroughly coat the pinion gears and drive shaft with molybdenum disulfide grease (Fig. 44).

7. Place pinion gear and drive shaft assembly into a differential carrier housing. Position exposed ends of the drive pin into the rounded insets of the housing. Make sure the teeth of the bevel and pinion gears mesh (Fig. 45).

8. Secure both differential carrier housings together as follows (Fig. 45):

A. Position the open ends of each housing together so the teeth of both bevel gears mesh with the teeth of both pinion gears.

B. While holding the housings together, twist the housings so the four holes on each housing are aligned to accept the the flanged hex head screws.

C. Insert screws. While tightening screws, make sure that all the gears stay messed together. **Do not over tighten screws.**

D. Hold housing and turn one of the axles. The other axle should turn in the opposite direction without any binding.

Installation

1. Park mower on a level surface. Make sure engine is OFF. Remove high tension lead from the spark plug.

2. Slide pulley onto differential axle so threads extend through pulley. Secure lock nuts and flat washers to the differential assembly and pulley. (Fig. 42).

3. Place differential assembly into the countershaft housing with the long axle first.

IMPORTANT: For the remainder of this procedure, support the axle so it is parallel to the drum. Possible damage to the bearings should be prevented.

4. Slide flangettes and bearing onto the long differential axle. Secure jam nuts, lock washers, and cable clip to the studs of screw plate (Fig. 40).

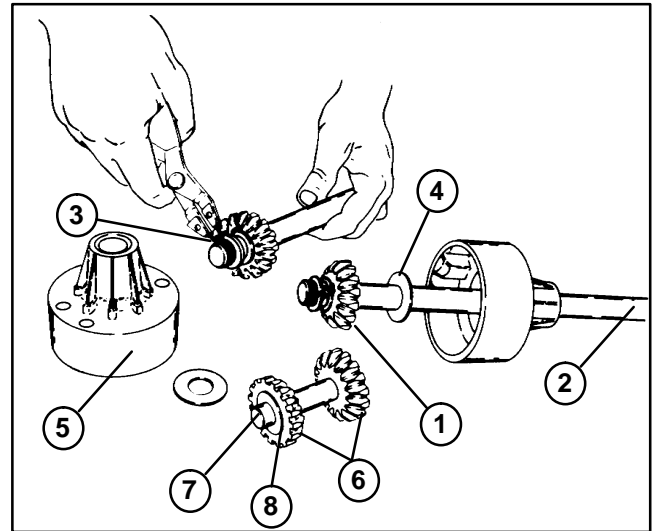

Figure 44

- | | |
|-------------------|--------------------|
| 1. Bevel gear | 5. Carrier housing |
| 2. Axle | 6. Pinion gear |
| 3. Retaining ring | 7. Drive pin |
| 4. Washer | 8. Thrust washer |

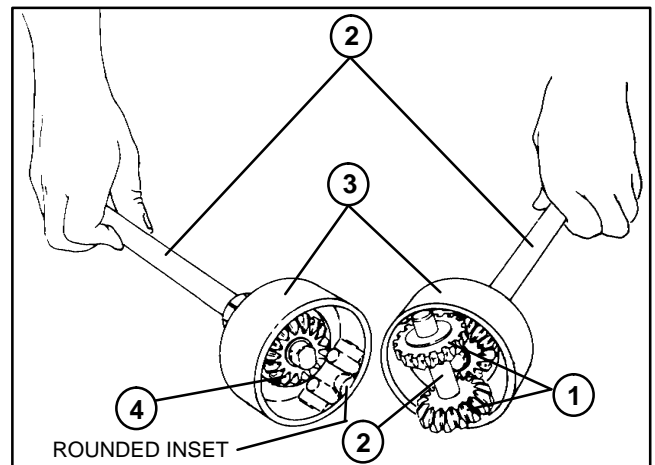

Figure 45

- | | |
|--------------------|---------------|
| 1. Pinion gear | 4. Bevel gear |
| 2. Drive shaft | 5. Axle |
| 3. Carrier housing | |

5. Slide locking collar onto the differential axle (Fig. 38).
6. Reinstall rear box cover (38) and differential boot (43) to the differential axle and countershaft housing (1) (Fig. 33).
7. Reinstall bearing housing for the **right** differential axle (see Differential Axle Pulley and Bearing Installation).
8. Reinstall bearing housing for the **left** differential axle (see Differential Axle Pulley and Bearing Installation).

IMPORTANT: Align axles so they turn freely before striking the locking collar.

9. Lock locking collar by striking it with a punch in the counterclockwise direction. Tighten set screw on the locking collar (Fig. 38).
10. Reinstall idler pulley to the countershaft housing (Fig. 40). Secure idler pulley with cap screw and lock washer. Tighten cap screw until washer just starts to compress. Spacer must be free to rotate (Fig. 41).
11. Adjust differential belt tension and reinstall front and rear box covers (see Differential Belt in the Adjustments section).

Differential Belt Replacement – Models 04051, 04052, and 04060

1. Park mower on a level surface. Make sure engine is OFF. Remove high tension lead from the spark plug.

2. Remove capscrews and lock washers securing the drum belt and reel drive covers to the right side plate. Remove belt covers.

3. Loosen cap screws securing drum and reel drive idler pulleys and spacers to the right side plate (Fig. 46 and 47). Rotate each idler pulley counterclockwise away from the backside of each belt to release belt tension. Remove both belts (Fig.48).

4. Remove capscrews and lock washers securing the front and rear box covers to the counter shaft housing. Slide covers away from the housing to expose the belt (Fig. 48).

5. Loosen cap screw on the engine side of the counter shaft housing that secures the idler pulley and spacer. Rotate idler pulley counterclockwise away from the backside of the belt to release belt tension. Cut belt and remove belt from the countershaft housing (Fig.48).

6. Remove both cap screws and locknuts securing the right rear bearing housing to side plate. Rotate housing 180° so the bottom of the housing points upward (Fig. 46 and 48).

7. Remove both cap screws and lock nuts securing the clutch housing to the side plate. Rotate housing 180° so the bottom of the housing points upward (Fig. 47 and 48).

8. Slide new belt over rotated housings and both box covers onto the differential and countershaft pulleys. Make sure idler pulley is positioned against the backside of the belt.

9. Rotate clutch and right rear bearing housings back into the upright position. Secure both housings to the sideplate with previously removed cap screws and lock nuts (Fig.48).

10. Adjust differential belt tension and reinstall rear and front box covers (see Differential Belt Adjustment).

11. Adjust belt tension on traction drive and reel drive belts and reinstall covers (see Drum Drive and Reel Drive Belt Adjustments).

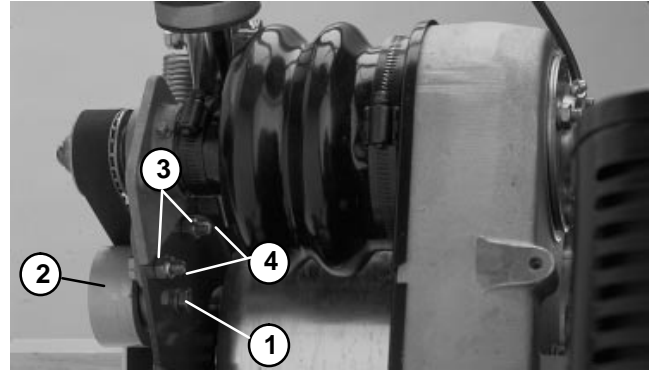

Figure 46

- | | |
|------------------------------|--------------|
| 1. Cap screw | 3. Lock nut |
| 2. Idler pulley (Drum drive) | 4. Cap screw |

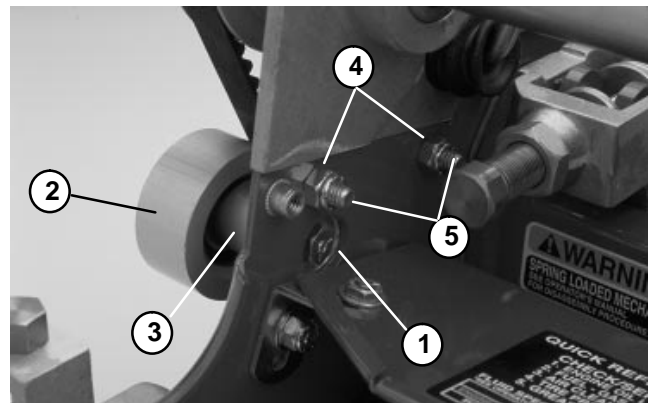

Figure 47

- | | |
|------------------------------|--------------|
| 1. Cap screw | 4. Lock nut |
| 2. Idler pulley (Reel drive) | 5. Cap screw |
| 3. Spacer | |

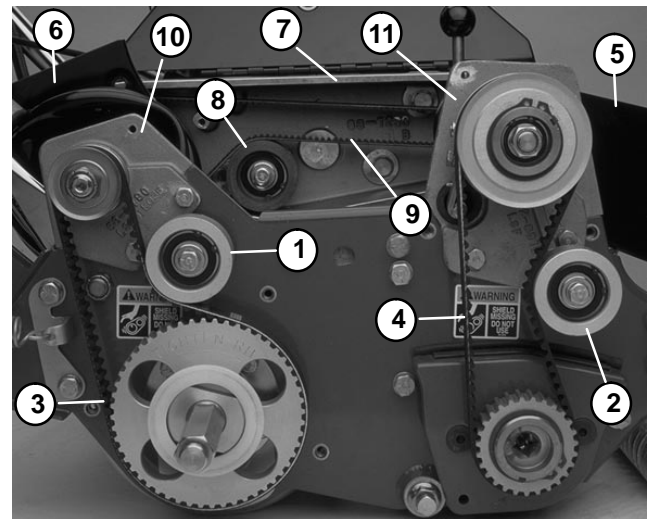

Figure 48

- | | |
|------------------------------|--------------------------------|
| 1. Idler pulley (Drum drive) | 7. Countershaft housing |
| 2. Idler pulley (Reel drive) | 8. Idler pulley (Differential) |
| 3. Belt (Reel Drive) | 9. Belt |
| 4. Belt (Drum drive) | 10. Bearing housing |
| 5. Front box cover | 11. Clutch housing |
| 6. Rear box cover | |

Traction and Reel Drive System

Differential Belt Replacement – Model 04050 Only

Removal

1. Place mower on a level surface. Make sure engine is OFF. Remove high tension lead from the spark plug. If the wheels are attached, place the mower on its kickstand and remove them.

2. Remove both drum drive covers using a 7/16-inch socket to remove the four cap screws and lock washers from each cover (Fig. 49).

3. From the mower rear, precede as follows (Fig. 50):

A. Remove two cap screws and lock washers securing the engine base to the back of the frame.

B. Leave front two cap screws securing the engine base to the frame in place. This will keep the engine in place.

C. Remove four capscrews, lock washers, and flat washers securing the countershaft housing to the frame.

4. Remove idler pulley from the bellcrank assembly. Remove remaining two cap screws and lock washers securing engine base to the frame. Remove both V-belts (Fig. 51).

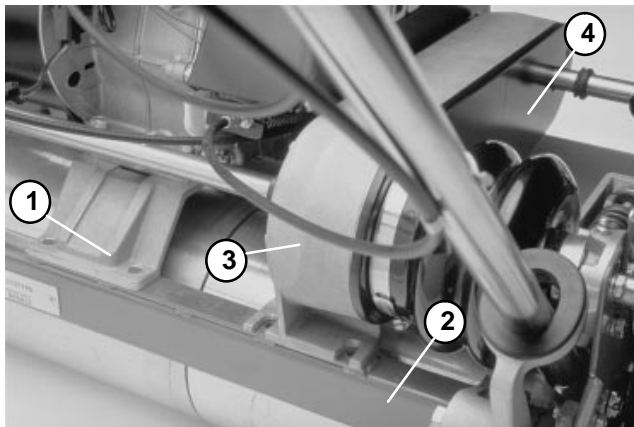

Figure 50

- | | |
|----------------|-------------------------|
| 1. Engine base | 3. Countershaft housing |
| 2. Frame | 4. Box cover |

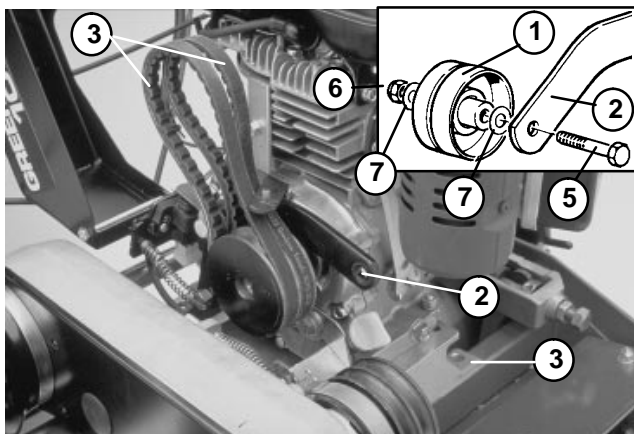



Figure 51

- | | |
|----------------------------|--------------|
| 1. Idler pulley | 5. Cap screw |
| 2. Bellcrank assembly | 6. Lock nut |
| 3. Cap screw & lock washer | 7. Washer |
| 4. V-belt | |



CAUTION

When lifting the engine from the frame, have at least two (2) people lift the engine to prevent personal injury.

5. Remove cable clips from the cables, wires, and handle assembly. Removal of the wires and cables is not necessary. Lift the engine with the engine base from the frame and set them behind the mower (Fig. 52)

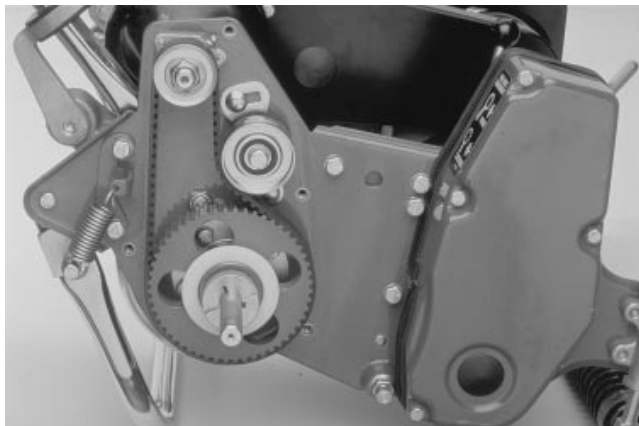

Figure 49

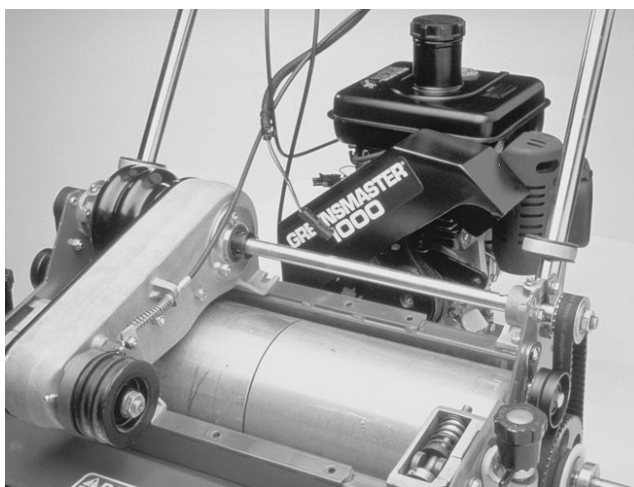

Figure 52

6. Use 9/16-inch open end wrench to hold the power shaft while backing off the lock nut with a 7/8-inch socket (Fig. 53).

7. Remove nut from the short axle of the differential as follows (Fig. 54):

A. Loosen small hose clamp securing the differential boot to the bearing housing.

B. Use drift punch in the hole of the short axle while removing the nut with a 7/8-inch socket.

8. Remove belts from both drum drive assemblies as follows (Fig. 55):

A. Loosen the lower carriage bolts and lock nuts securing the idler brackets to the frame.

B. Remove upper carriage bolts and lock nuts securing the idler brackets to the frame.

C. Swing both idler pulleys forward. Remove belts.

9. Remove shaft input pulley from the power shaft. Remove key from shaft with drift punch (Fig. 56).

10. Slide pulley off the short axle on the right side of the countershaft housing. Remove key from the axle with a drift punch (Fig. 57).

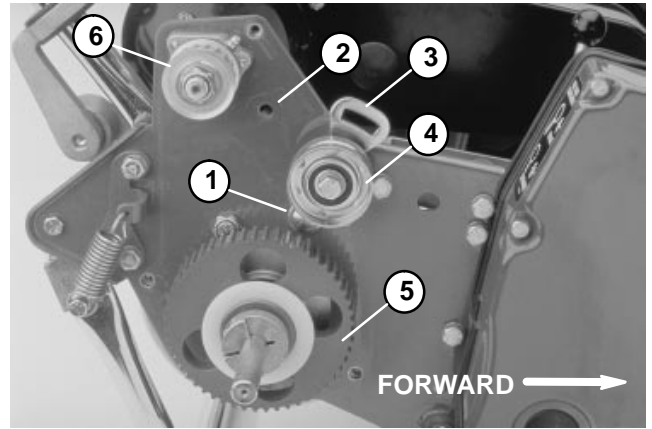

Figure 55

- | | |
|-------------------------------|----------------------|
| 1. Carriage bolt (Lower) | 4. Idler pulley |
| 2. Carriage bolt hole (Upper) | 5. Drum shaft pulley |
| 3. Idler bracket | 6. Pulley |

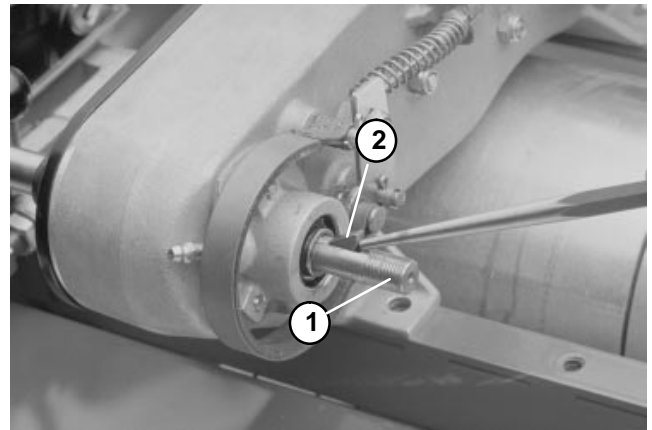

Figure 56

- | | |
|----------------|--------|
| 1. Power shaft | 2. Key |
|----------------|--------|

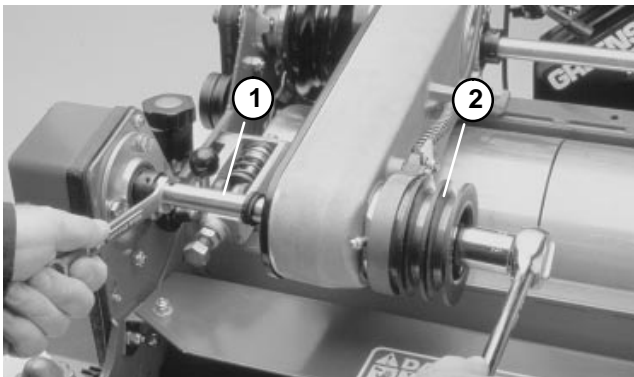

Figure 53

- | | |
|----------------|-----------------------|
| 1. Power shaft | 2. Shaft Input pulley |
|----------------|-----------------------|

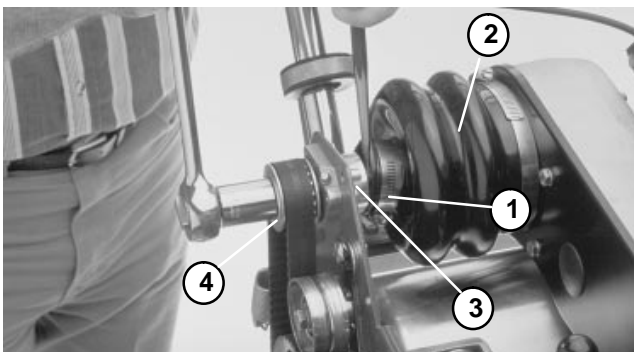

Figure 54

- | | |
|----------------------|--------------------|
| 1. Small hose clamp | 3. Bearing housing |
| 2. Differential boot | 4. Pulley |

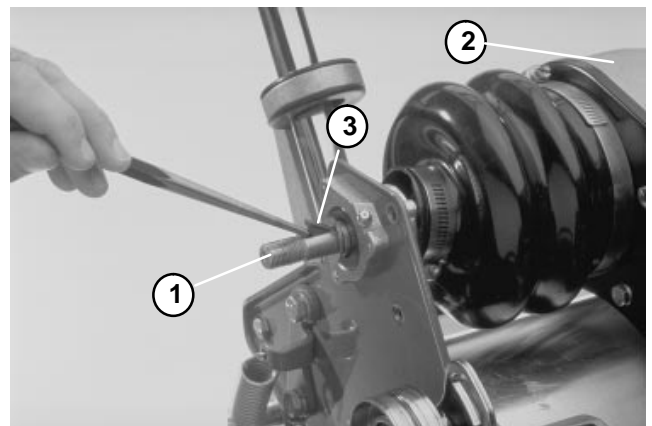

Figure 57

- | | |
|-------------------------|--------|
| 1. Axle (Short) | 3. Key |
| 2. Countershaft housing | |

Note: The locking collar securing the long axle to the countershaft housing is a eccentric flange type.

11. Loosen the set screw on the locking collar. Unlock collar by striking it with a punch in the clockwise direction (Fig. 58).

12. Remove three cap screws and lock washer securing the box cover to the countershaft housing. Pull cover from housing. Loosen both carriage bolts and lock nuts securing the idler pulley to the countershaft housing. Slide idler pulley away from the belt (Fig. 59).

13. Use a rubber hammer to carefully tap the countershaft housing off the power shaft. Alternate the hammer between the long axle and the bearing housing end of the counter shaft housing to prevent damage to the bearings(Fig. 60).

14. Remove three socket head cap screws and lock washers from the side plate (RH) and bearing housing (Fig. 61).

15. Slide differential assembly to the left to allow removal of the belt without bending or twisting. Remove old belt from the differential pulley and countershaft pulley (Fig. 62).

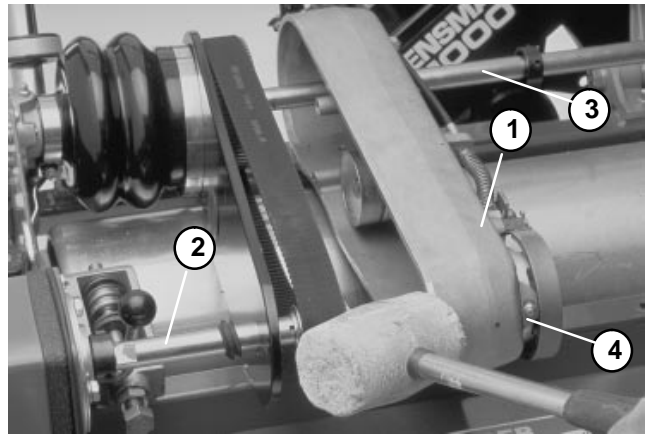

Figure 60

- 1. Countershaft housing
- 2. Power shaft
- 3. Axle (Long)
- 4. Bearing housing

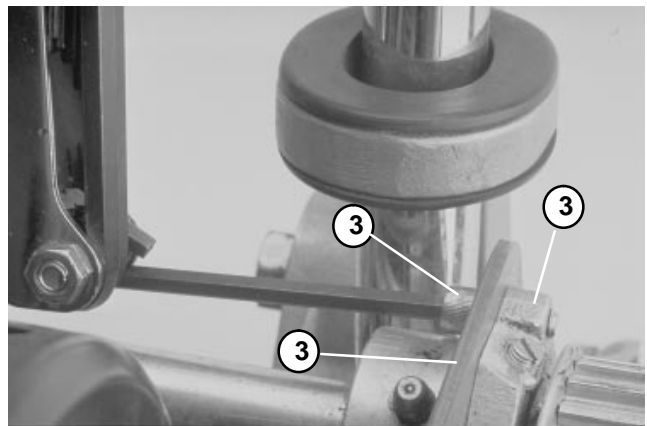

Figure 61

- 1. Socket head cap screw
- 2. Side plate (LH shown)
- 3. Bearing housing

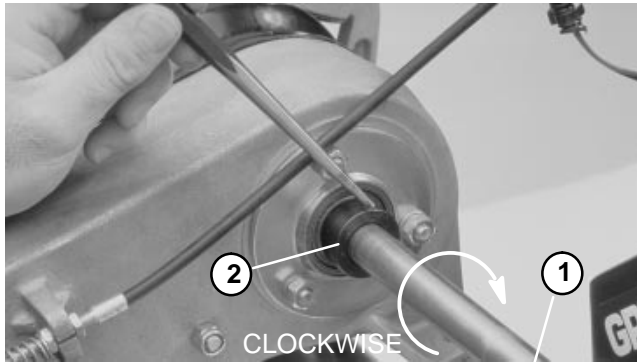

Figure 58

- 1. Axle (Long)
- 2. Locking collar

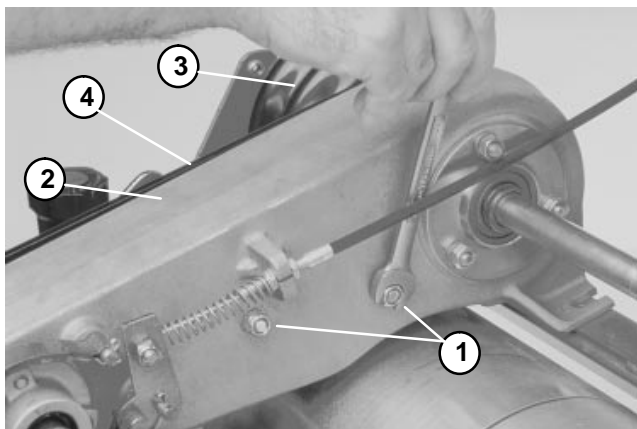

Figure 59

- 1. Lock nut (Idler pulley)
- 2. Countershaft housing
- 3. Differential boot
- 4. Box cover



Figure 62

- 1. Differential assembly
- 2. Belt

Installation

1. Park mower on a level surface. Make sure engine is OFF. Remove high tension lead from the spark plug.
2. Install new belt to the differential pulley and countershaft pulley. Slide differential assembly to the right side plate (Fig. 62).
3. Secure three socket head cap screws and lock washers to the side plate (RH) and bearing housing (Fig. 61).
4. Use a rubber hammer to carefully tap the countershaft housing onto the power shaft. Alternate the hammer between the long axle and the bearing housing end of the counter shaft housing to prevent damage to the bearings (Fig. 60).
5. Secure countershaft housing to the frame with the four cap screws, lock washers, and flat washers (Fig. 50).
6. Install pulley to the short axle as follows (Fig. 57 and 54).
 - A. Apply anti-seize lubricant to the axle keyway area. Reinstall key to the axle. Slide pulley onto short axle on the right side of the countershaft housing.
 - B. Screw nut onto the short axle of the differential. Use drift punch in the hole of the short axle while torquing the nut from 30 to 40 ft-lb (4.1 to 5.5 kg-m).
 - C. Secure differential boot to the bearing housing with the small hose clamp.
7. Make sure drum belts will be properly aligned.
 - A. Center both pulleys on the differential axles to obtain an equal distance between the side plates and pulleys (Fig. 63).
 - B. Lock collar by striking it with a punch in the counterclockwise direction. Tighten set screw on the locking collar (Fig. 58).
8. Install shaft input pulley to the power shaft.
 - A. Apply anti-seize lubricant to the power shaft keyway area. Reinstall key to shaft keyway (Fig. 56).
 - B. Reinstall shaft input pulley to the power shaft. Screw lock nut onto shaft. Torque nut from 30 to 40 ft-lb (4.1 to 5.5 kg-m) while locking shaft with a 9/16-inch open end wrench (Fig. 64).
9. Reinstall belts to both drum drive assemblies as follows (Fig. 55):
 - A. Reinstall belt onto the drum shaft pulley and pulley on both sides of mower.
 - B. Swing idler pulley into belt. Reinstall upper carriage bolts and lock nuts to both sides of the frame. Do not tighten.
 - C. Keep lower carriage bolts and lock nuts on both sides of the frame loose.
10. Lift engine with the engine base from behind the mower onto the frame. Reinstall cable clips to the cables, wires, and handle assembly (Fig. 52)



CAUTION

When lifting the engine to the frame, have at least two (2) people lift the engine to prevent personal injury.

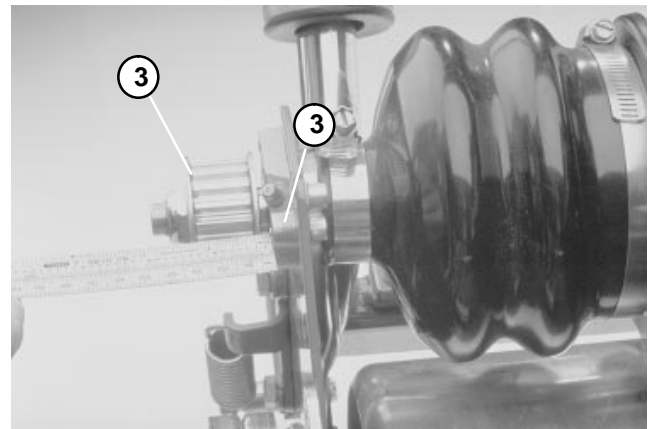

Figure 63

1. Pulley

2. Side plate

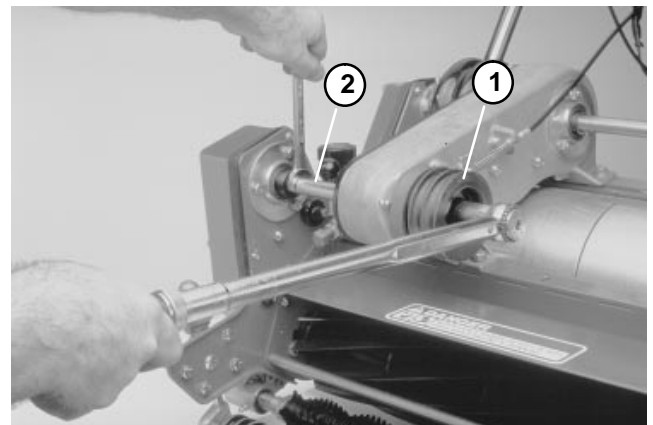

Figure 64

1. Shaft input pulley

2. Power shaft

11. Secure engine to the frame as follows:

A. Reinstall both V-belts (Fig. 51).

A. Position the engine base to obtain from 5.34 to 5.46 inches (13.6 to 13.9 cm) between the engine output shaft and power shaft center lines (Fig. 65).

B. Align machined face of input power and shaft input pulleys to within a maximum of 0.03 inch (0.76 mm) misalignment (Fig. 65).

C. Secure engine base to the front of the frame with two cap screws and lock washers (Fig. 51).

D. Secure engine base to the back of the frame with two cap screws and lock washers (Fig. 50).

E. Reinstall idler pulley to the bellcrank assembly (Fig. 51).

IMPORTANT: Over tightening belts will overload the bearings and increase wear on the belt.

12. Adjust tensions of differential and both drum drive belts from 20 to 25 lbs (89 to 111 N) of force. Use a scale to pull on the idler pulley while securing the idler brackets by tightening both carriage bolts and lock nuts (Fig. 66).

13. Secure box cover to the countershaft housing with the three cap screws and lock washers (Fig. 50)

14. Reinstall both drum drive covers using a 7/16-inch socket to tighten the four cap screws and lock washers to each cover (Fig. 49).

15. Start the unit and run for a minimum of one minute. Shut the engine off. The inside edge of the differential belt should not hang over either the idler pulley, countershaft pulley, or differential pulley (Fig. 67).

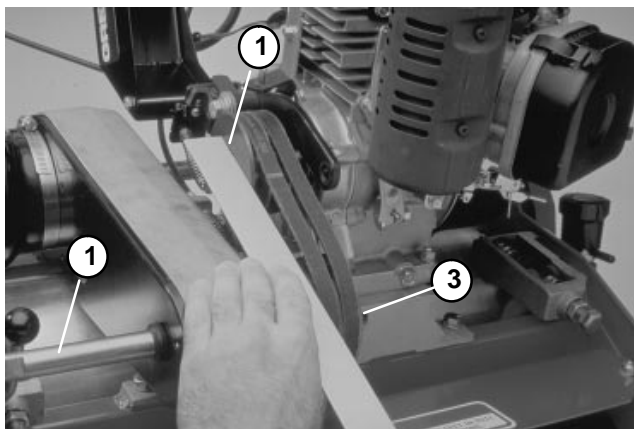

Figure 65

- 1. Power shaft
- 2. Input power pulley
- 3. Shaft input pulley

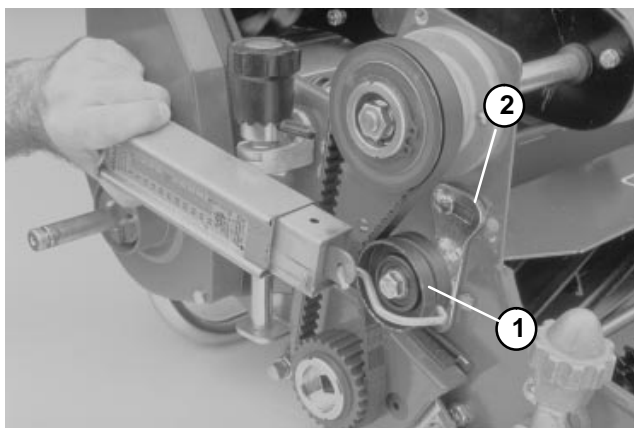

Figure 66

- 1. Idler pulley
- 2. Idler pulley bracket

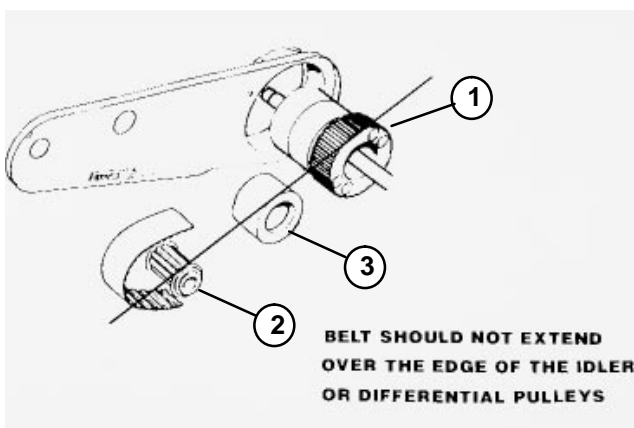

Figure 67

- 1. Differential pulley
- 2. Counter shaft pulley
- 3. Idler pulley

Lubrication

The mower should be greased at least after every 25 hours of operation. Lubricate grease fittings using No. 2 multipurpose lithium base grease. A hand operated grease gun is recommended for best results.

1. Park mower on a level surface. Make sure engine is OFF. Remove high tension lead from the spark plug.
2. Wipe each grease fitting with a clean rag.

IMPORTANT: Do not apply too much pressure or grease seals will become permanently damaged.

3. The grease fitting locations are as follows:

A. Both bearing housings for the differential axles, both flangettes for the drum shafts, and the flangette on the countershaft housing (Fig. 68).

B. The clutch housing and bearing housing for the power shaft (Fig. 69).

4. Wipe off excess grease.

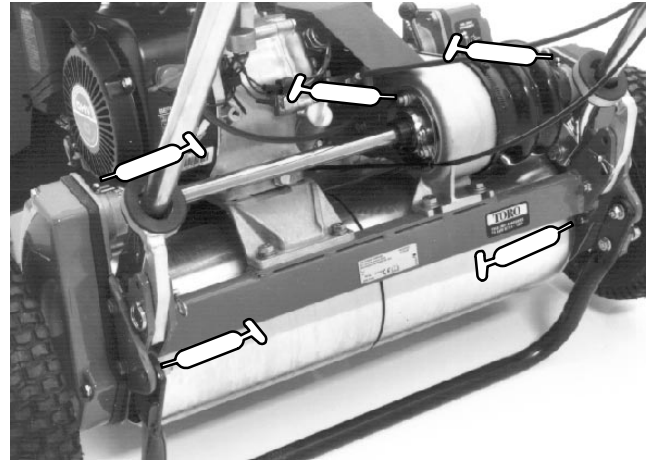

Figure 68

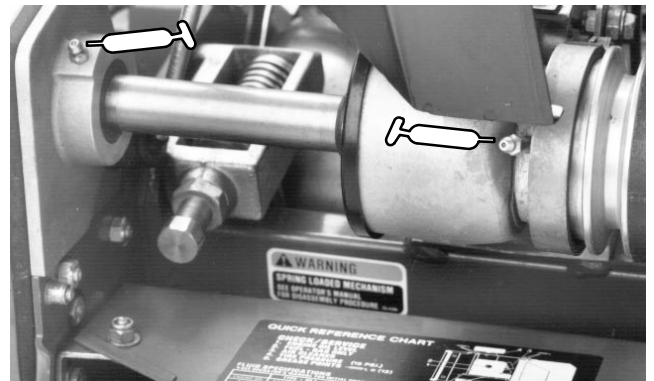

Figure 69



Electrical System

Table of Contents

WIRING SCHEMATICS	2	COMPONENT TESTING	8
Late Model Kawasaki FE120 Engines	2	Interlock Module and Clutch (Interlock) Switch	
Late Model Kawasaki FE120 Engines		No Operator Presence Control	8
with Operator Presence Control	3	With Operator Presence Control	9
Early Model Kawasaki FE120 Engines	4	Ignition System Operation	10
Early Model Kawasaki FE120 Engines		Igniter	11
With Operator Presence Control	5	Ignition Coil	12
SPECIAL TOOLS	6	SERVICE AND REPAIRS	13
TROUBLESHOOTING	7	Interlock Switch	13
Engine Will Not Start	7	Operator Presence Control Switch	14
Engine Will Start , But Will Not Run	7	Spark Plug	15

Electrical System

Wiring Schematics

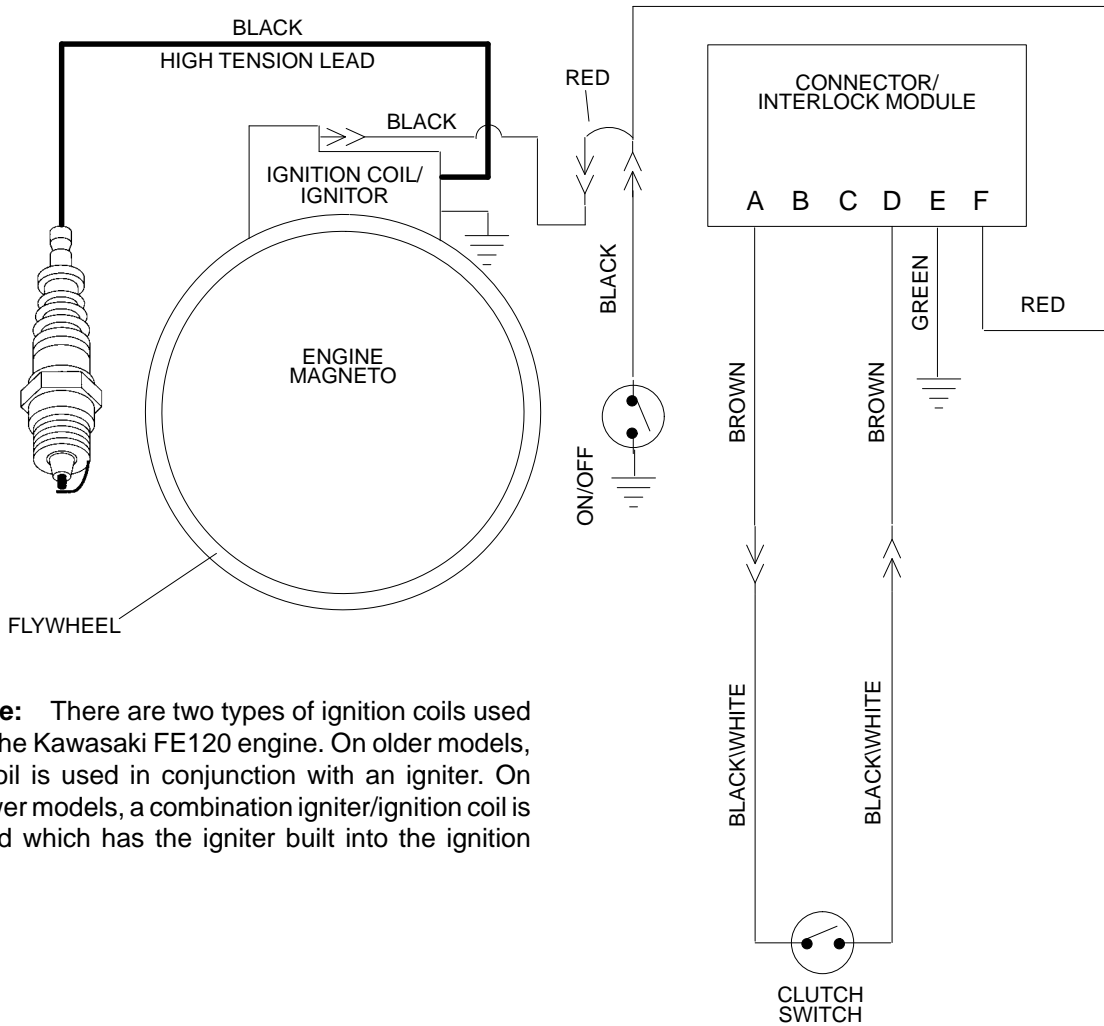

Note: There are two types of ignition coils used on the Kawasaki FE120 engine. On older models, a coil is used in conjunction with an igniter. On newer models, a combination igniter/ignition coil is used which has the igniter built into the ignition coil.

Late Model Kawasaki FE120 Engines

ON/OFF switch is open in the ON position
 CLUTCH SWITCH is closed when the clutch is DISENGAGED

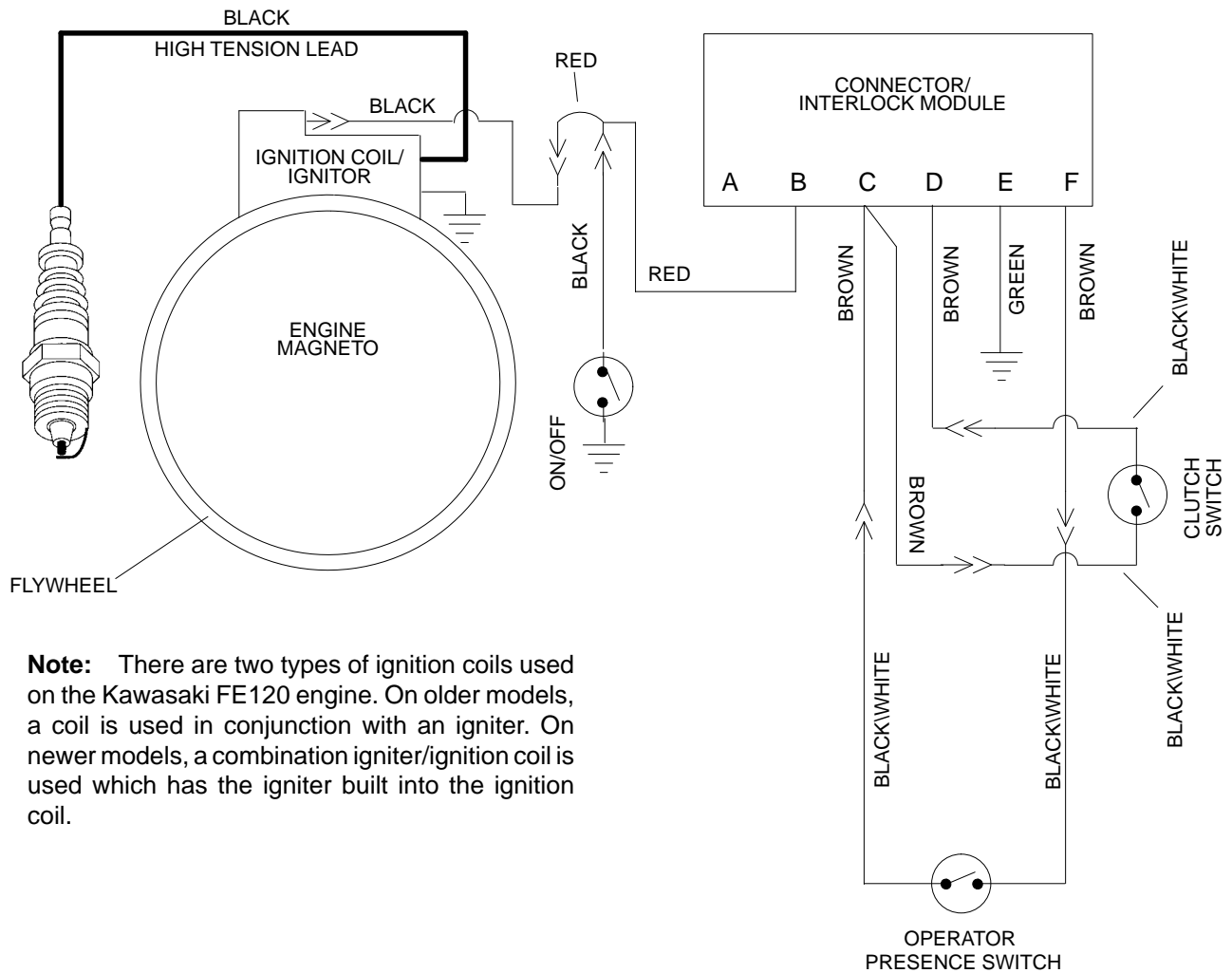

Note: There are two types of ignition coils used on the Kawasaki FE120 engine. On older models, a coil is used in conjunction with an igniter. On newer models, a combination igniter/ignition coil is used which has the igniter built into the ignition coil.

Late Model Kawasaki FE120 Engines with Operator Presence Control

ON/OFF switch is open in the ON position

CLUTCH SWITCH is closed when the clutch is DISENGAGED

OPERATOR PRESENCE SWITCH is closed when the bail is held

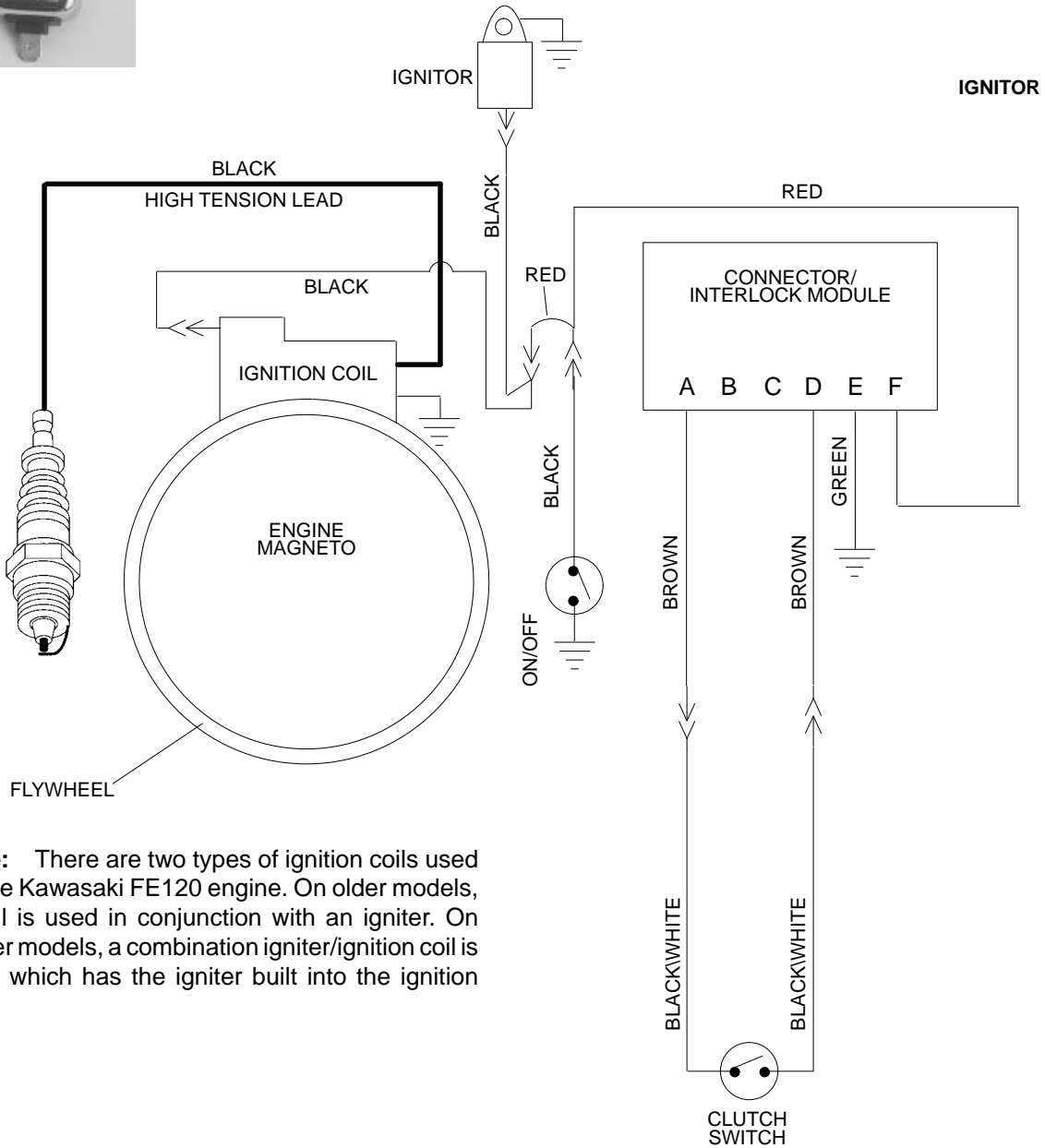

Note: There are two types of ignition coils used on the Kawasaki FE120 engine. On older models, a coil is used in conjunction with an igniter. On newer models, a combination igniter/ignition coil is used which has the igniter built into the ignition coil.

Early Model Kawasaki FE120 Engines

ON/OFF switch is open in the ON position
 CLUTCH SWITCH is closed when the clutch is DISENGAGED



IGNITOR

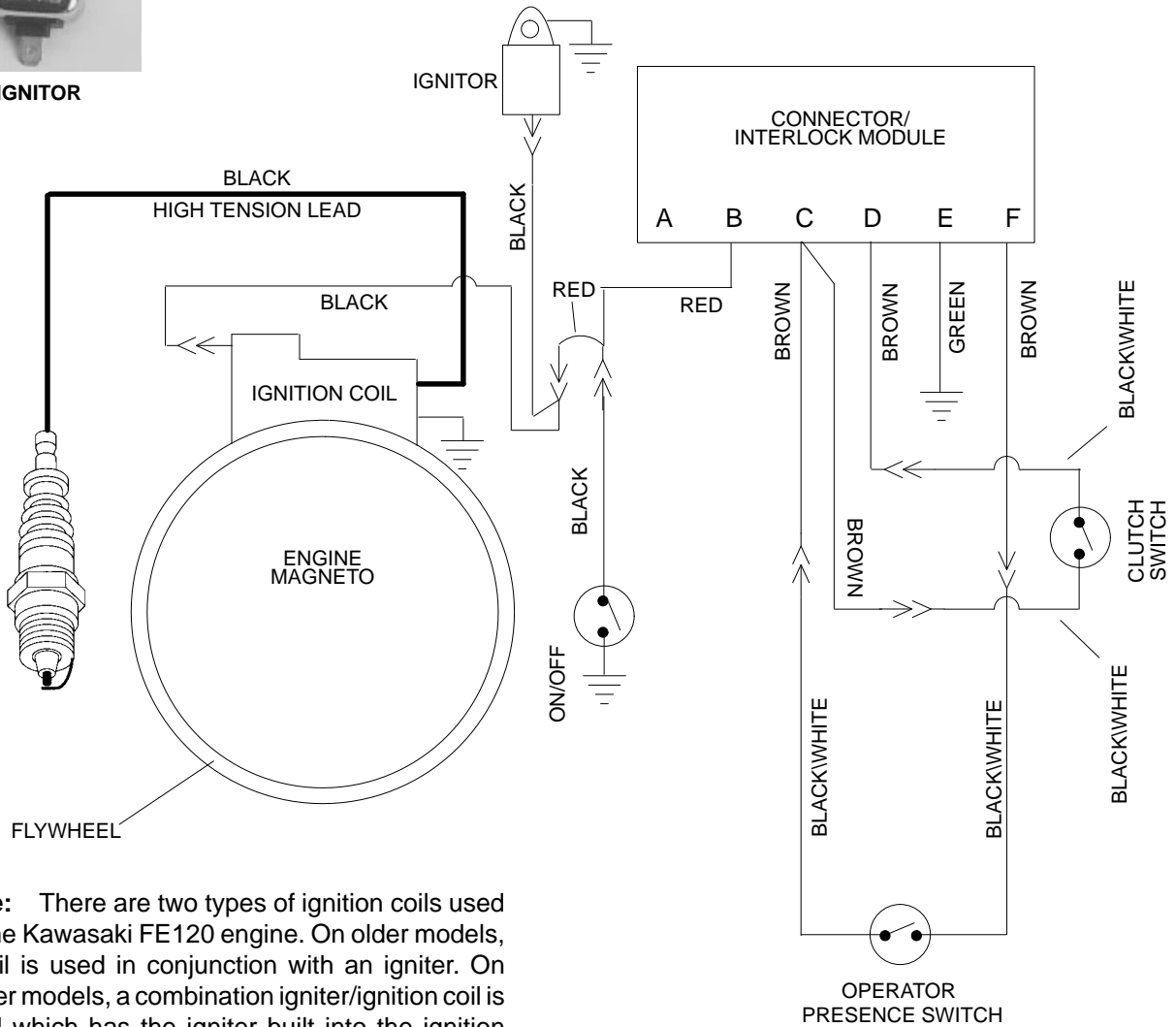

Note: There are two types of ignition coils used on the Kawasaki FE120 engine. On older models, a coil is used in conjunction with an igniter. On newer models, a combination igniter/ignition coil is used which has the igniter built into the ignition coil.

Early Model Kawasaki FE120 Engines with Operator Presence Control

ON/OFF switch is open in the ON position

CLUTCH SWITCH is closed when the clutch is DISENGAGED

OPERATOR PRESENCE SWITCH is closed when the bail is held

Special Tools

Order special tools from the *TORO SPECIAL TOOLS AND APPLICATIONS GUIDE (COMMERCIAL PRODUCTS)*.

Some tools may also be available from a local supplier.

Multimeter

The meter can test electrical components and circuits for current, resistance, or voltage.

NOTE: Toro recommends the use of a DIGITAL Volt-Ohm-Amp multimeter when testing electrical circuits. The high impedance (internal resistance) of a digital meter in the voltage mode will make sure that excess current is not allowed through the meter. This excess current can cause damage to circuits not designed to carry it.

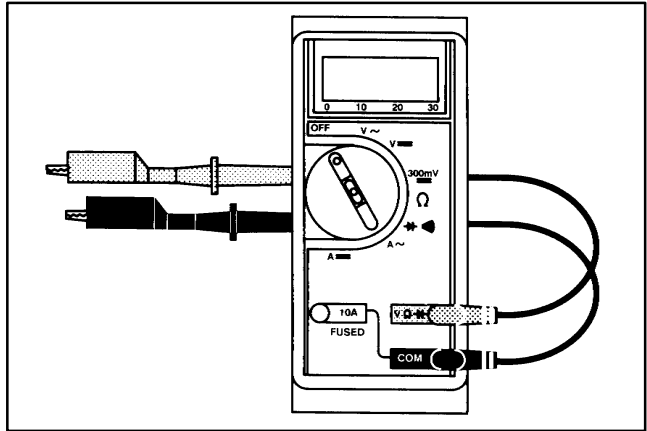

Figure 1

Skin-Over Grease – TOR50547

Special non-conductive grease which forms a light protective skin which helps waterproof electrical switches and contacts.

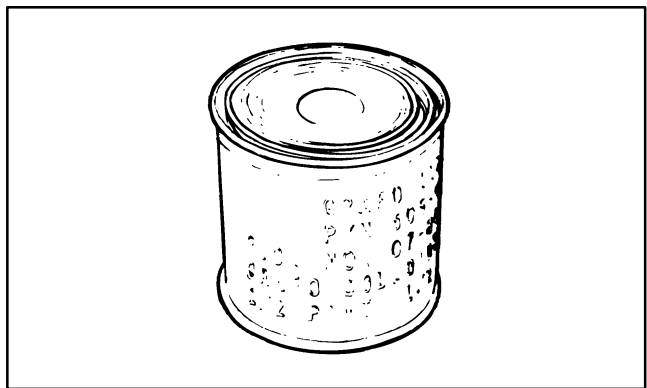

Figure 2

Spark Tester – TOR4036

For testing electronic ignitions. Saves time because you will know if the ignition is causing the problem on a non-starting engine. The tester determines if ignition spark is present.

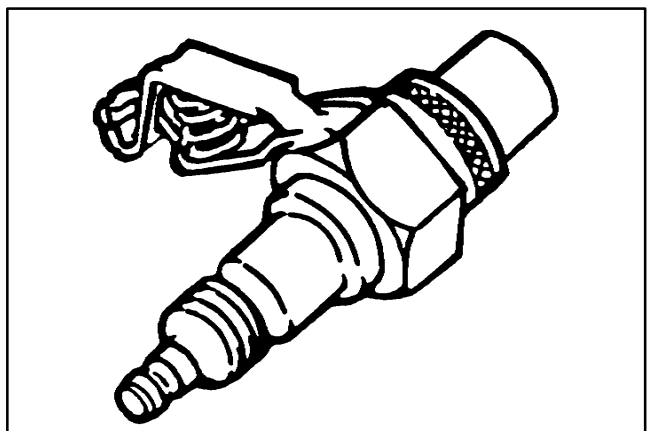

Figure 3

Troubleshooting



CAUTION

Remove all jewelry, especially rings and watches, before doing any electrical troubleshooting or testing.

For effective troubleshooting and repairs, you must have a good understanding of the electrical circuits and components used on this machine (see Wiring Schematic section of this chapter).

The interlock switch must not be by-passed, it must be connected for proper troubleshooting and safety.

NOTE: See the **Kawasaki FE161 & FE170 Service Manual** and **Kawasaki FE120 Service Manual Supplement** in Chapter 3 – Engine for troubleshooting of electrical problems related to the ignition system. However, ignition system testing is covered in this chapter. The ignition system for the FE120 engine is not fully covered in the service manual.

. 10r16FA, rG3I; mK

Problem	Possible Causes	Correction
Engine will not start	<p>ON/OFF switch is in the OFF position or is grounded.</p> <p>Spark plug lead is not connected.</p> <p>Electrical wires are loose or damaged.</p> <p>Clutch switch is not adjusted or faulty.</p> <p>Interlock module is faulty.</p>	<p>Turn switch to ON, or replace switch.</p> <p>Make sure spark plug lead is connected.</p> <p>Check electrical connections. Repair wiring.</p> <p>Adjust or replace clutch switch.</p> <p>Replace interlock module.</p>
Engine will start , but will not run	<p>Electrical wires are loose or damaged.</p> <p>Operator presence control switch is not adjusted or faulty.</p> <p>Interlock module is faulty.</p>	<p>Check electrical connections. Repair wiring.</p> <p>Adjust or replace clutch switch.</p> <p>Replace interlock module.</p>

Component Testing

For accurate resistance and/or continuity checks, electrically disconnect the component being tested from the circuit (e.g. unplug the ON/OFF switch connector before doing a continuity check). Individual components should be electrically isolated (e.g. disconnect all leads or remove from circuit) from the circuit when tested.



CAUTION

When testing electrical components for continuity with a multimeter (ohms setting), make sure that power to the circuit has been disconnected.



WARNING

The ignition system produces a dangerously high voltage. Do not touch the spark plug, ignition coil, igniter, or spark plug lead while the engine is running; you can receive a severe electrical shock.

Interlock Module and Clutch (Interlock) Switch – No Operator Presence Control

The interlock module prevents the engine from starting unless the clutch switch is closed (clutch DISENGAGED). After a safe start, the engine will continue to run with the clutch switch open (clutch ENGAGED) or closed.

If the engine will not start, perform the following tests to determine if the interlock module or clutch switch is at fault.

1. Check that there is a good ground between the interlock module and the engine, Check all other electrical connections and the interlock module for damage. Replace any damaged wiring or components.
2. Check the adjustment and continuity of the clutch switch.
 - A. Disconnect both black\white wires from both brown wires connected to the interlock module.
 - B. Place traction clutch lever in the ENGAGED position. The switch should be open.
 - C. Place traction clutch lever in the DISENGAGED position. The switch should be closed.
 - D. Adjust interlock switch until it opens and closes properly when the traction lever is in the ENGAGED and DISENGAGED positions. See Interlock Switch in the Adjustments section.
 - E. Reconnect both brown wires to both black\white wires connected to the clutch switch.

NOTE: See the **Kawasaki FE161 & FE170 Service Manual** and **Kawasaki FE120 Service Manual Supplement** for more component testing information.

3. Start the engine. If the engine does not start, check the interlock module using the following steps.
4. Disconnect red wire (male connector) where it connects to the black wire leading to the ignition coil. On older models, disconnect red wire (male connector) where it connects to the black wires leading to the ignition coil and igniter.
 - A. Start the engine. The engine should start.
 - B. Ground the red wire (male connector) to the engine block and start the engine. The engine should **not** start.
 - C. Reconnect the red wire to the black wire.
5. Disconnect both brown wires from both black\white wires.
 - A. Start the engine. The engine should **not** start.
 - B. Jumper across the two brown wires and start the engine. The engine should start.
 - C. Reconnect both black\white wires to both brown wires.
6. Replace interlock module if it fails either off the tests in step 4 or 5.

Interlock Module and Clutch (Interlock) Switch – With Operator Presence Control

The interlock module prevents the engine from starting unless the clutch switch is closed (clutch DISENGAGED). After a safe start, the engine will continue to run with the clutch switch open (clutch ENGAGED) or closed. However, the operator presence bail must be engaged (held to against the handle) for the engine to run when the clutch is ENGAGED. With the clutch ENGAGED, the engine will stop when the operator presence bail is released.

If the engine will not start, perform the following tests to determine if the interlock module or clutch switch is at fault.

1. Check that there is a good ground between the interlock module and the engine, Check all other electrical connections and the interlock module for damage. Replace any damaged wiring or components.

2. Check the adjustment and continuity of the clutch switch.

A. Disconnect both black\white wires from both brown wires connected to the interlock module that lead to the clutch switch.

B. Place traction clutch lever in the ENGAGED position. The switch should be open.

C. Place traction clutch lever in the DISENGAGED position. The switch should be closed.

D. Adjust interlock switch until it opens and closes properly when the traction lever is in the ENGAGED and DISENGAGED positions. See Interlock Switch in the Service And Repairs section.

E. Reconnect both black\white wires to the brown wires leading to the interlock module.

3. Check the adjustment and continuity of the operator presence control switch.

A. Disconnect both black\white wires at the switch from both brown wires leading from the wire harness.

B. Hold the bail against the handle. The switch should be closed.

C. Release the bail from the handle. The switch should be open.

D. Adjust operator presence control switch until it closes and opens properly when the bail is held against and released from the handle. See Operator Presence Control Switch in the Service And Repairs section.

E. Reconnect both brown wires to the black\white wires connected to the operator presence control switch.

4. Start the engine. If the engine does not start, check the interlock module using the following steps.

5. Disconnect red wire (male connector) where it connects to the black wire leading to the ignition coil. On older models, disconnect red wire (male connector) where it connects to the black wires leading to the ignition coil and igniter.

A. Start the engine. The engine should start.

B. Ground the red wire (male connector) to the engine block and start the engine. The engine should **not** start.

C. Reconnect the red wire to the black wire.

6. Disconnect both brown wires from the black/white wires leading to the clutch switch.

A. Start the engine. The engine should **not** start.

B. Jumper across the two brown wires and start the engine. The engine should start.

C. Reconnect both black\white wires to both brown wires.

7. Disconnect both brown wires from the black/white wires leading to the operator presence control switch.

A. Start the engine. The engine should start.

B. Jumper across the two brown wires and start the engine. The engine should start.

C. Place traction clutch lever in the ENGAGED position. The engine should continue to run.

D. Remove jumper from the brown wires. The engine should stop.

E. Reconnect both black\white wires to the brown wires.

8. Replace interlock module if it fails either off the tests in steps 5, 6, or 7.

Ignition System Operation

Making a System Tester

This simple tester can be made if a commercial spark tester is not available. It can determine if the ignition system is operating properly.

1. Use a new **NGK BPR5ES** or equivalent spark plug.
2. Remove the ground electrode from the test plug. This gives the spark plug a larger gap, which simulates the spark required under actual engine conditions.
3. Use 18 gauge insulated wire, an alligator clip, and large spring clip to make a lead assembly.
4. Slide a 1–1/4 inch length of 1/2-inch I.D. clear fuel line over the threads of the spark plug. The spark will be more visible, and the fuel line will shade the plug firing tip.

Testing the Ignition System



WARNING

The ignition system produces a dangerously high voltage. Do not touch the spark plug, ignition coil, or spark plug lead while the engine is running; you can receive a severe electrical shock.

Note: Do not remove spark plug from the engine. The spark plug is necessary to maintain normal starting speeds.

1. Remove high-tension lead from the spark plug, and connect it to the test spark plug.
2. Connect large spring clip around the hex portion of the test spark plug. Connect alligator clip to a good ground on the engine block.
3. Make sure ON/OFF switch is in the ON position.

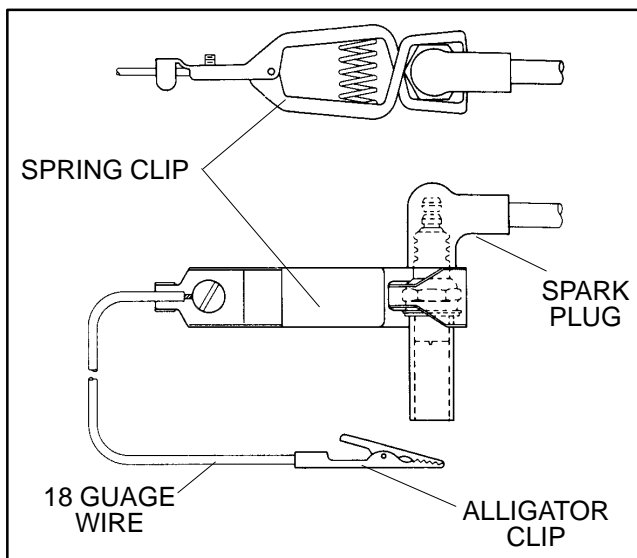

Figure 4

4. Start the engine and observe the test spark plug. Visible and audible sparks should be produced.
5. If visible and audible sparks are produced, the ignition system is operating properly.
6. If visible and audible sparks are not produced, the ignition system is not operating properly.
 - A. Check wires and connectors of the ON/OFF switch, igniter, ignition coil, and combination igniter and ignition coil (on later models) for grounding or damaged insulation.
 - B. If wires and connectors are good, test the igniter, ignition coil, and combination igniter and ignition coil (on later models) individually.
 - C. If the igniter, ignition coil, and combination igniter and ignition coil (on later models) test properly see Interlock Module and Clutch (Interlock) Switch in this section for further testing.

Igniter

The igniter consists of transistorized circuitry that controls the firing sequence of the spark plug in conjunction with the ignition coil. Mounted on the engine block, the igniter casing is grounded directly to the engine. A single black wire makes a circuit from the igniter to the primary of the ignition coil.

1. Park mower on a level surface. Make sure engine is OFF.

2. Remove black wire from the bottom of the igniter.

3. Use a digital multimeter set to the ohms scale; take internal resistance of the igniter.

A. Contact black (-) test lead to the igniter mounting screw (ground).

B. Contact red (+) test lead to the terminal from which the black wire was removed.

C. The internal resistance should be about **7.8** to **8.1 K Ω** .

4. If the internal resistance value is **not** within specification, replace old igniter with a new one. Reconnect black lead.

A. Try starting the engine.

B. If the engine does not start, replace the ignition coil.

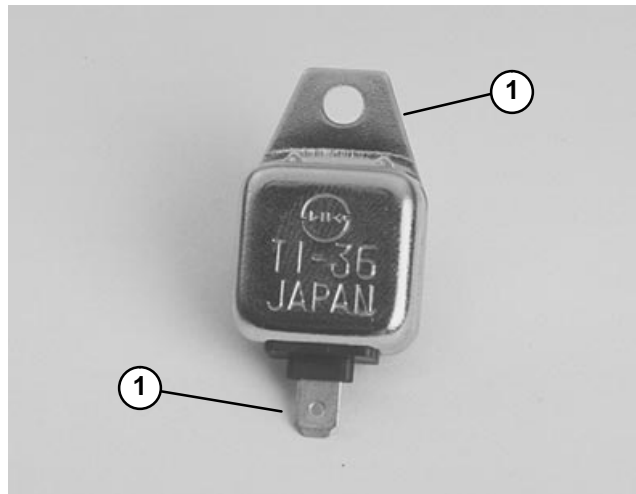

Figure 5

1. Ground

2. Wire connector

5. If the internal resistance value is within specification, test the ignition coil.

Ignition Coil

A commercial coil tester can be used to test the ignition coil. If a tester is available, test the ignition coil as suggested in the **Kawasaki FE161 & FE170 Service Manual** and **Kawasaki FE120 Service Manual Supplement**

The coil can be tested for a badly shorted or broken winding with a digital ohmmeter. However, a ohmmeter can not detect layer shorts and shorts resulting from insulation breakdown under high running voltages.

Note: Prior to taking small resistance readings with a digital multimeter, short the test leads together. The meter will display a small resistance value (usually 0.5 ohms or less). This resistance is due to the internal resistance of the meter and test leads. Subtract this value from the measured value of the component you are testing.

Note: There are two types of ignition coils used on the Kawasaki FE120 engine. On older models, a coil is used in conjunction with an igniter. On newer models, a combination igniter/ignition coil is used which has the igniter built into the ignition coil.

1. Park mower on a level surface. Make sure engine is OFF

2. Isolate ignition coil. Disconnect high tension lead from spark plug and black wire on the coil.

3. Measure primary winding resistance between the primary lead and ground. Winding resistance should be from **0.8 to 1.0** ohms. Winding and circuit resistance should be from **0.6 to 1.1** ohms for new combination **igniter/ignition** coils.

A. If resistance is 0 ohms, the primary winding is shorted. Replace ignition coil.

B. If resistance is high or infinity (∞) ohms, the primary winding is open. Replace ignition coil.

4. Measure secondary winding resistance between the secondary lead and ground. Winding resistance should be from **7.0 to 9.0** K Ω . Winding resistance should be from **5.8 to 9.6** K Ω for new combination **igniter/ignition** coils.

A. If resistance is low or 0 ohms, the primary winding is shorted. Replace ignition coil.

B. If resistance is high or infinity (∞) ohms, the primary winding is open. Replace ignition coil.

C. Check the high tension lead for damage. Replace ignition coil if lead is damaged.

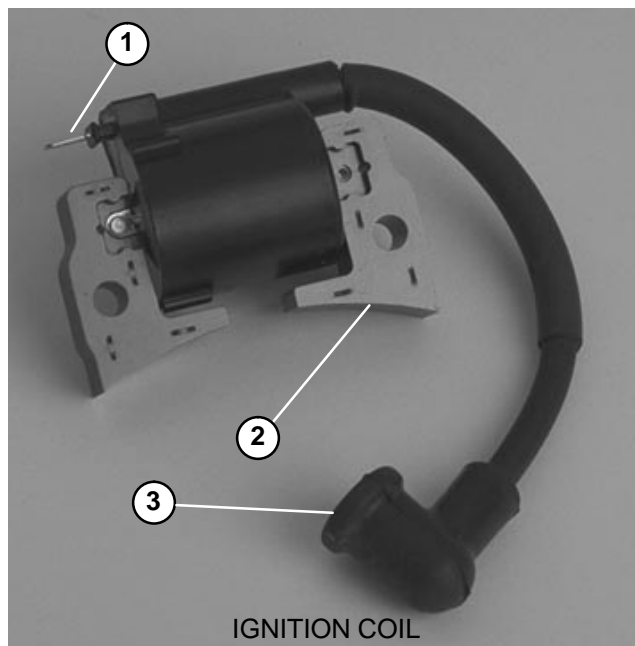

Figure 6

- 1. Primary lead
- 2. Ground
- 3. Secondary lead

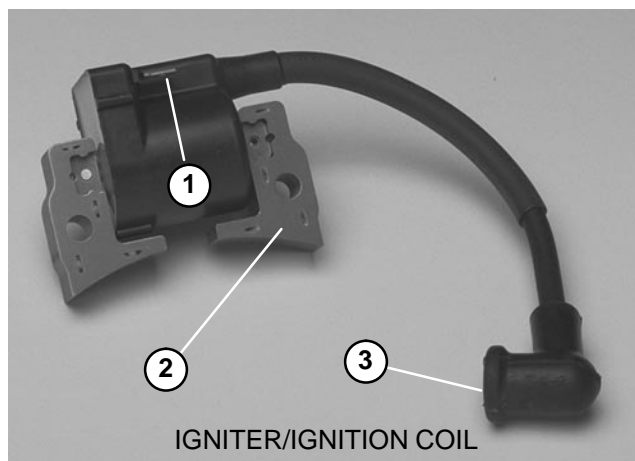

Figure 7

- 1. Primary lead
- 2. Ground
- 3. Secondary lead

5. If resistances are good, the ignition coil windings are probably good. However, if the ignition still does not perform after all other components have been checked, replace coil with a new one.

Service and Repairs

NOTE: See the **Kawasaki FE161 & FE170 Service Manual** and **Kawasaki FE120 Service Manual Supplement** for more component repair information.

Interlock Switch

Adjustment

1. Make sure the engine is OFF and traction lever is DISENGAGED.
2. Loosen both switch mounting nuts and move switch until the switch plunger is depressed 0.18 to 0.24 inch (4.6 to 6.1 mm) (switch closed).
3. Tighten switch mounting nuts.
4. Engage traction lever and verify that the switch plunger is depressed no more than 0.06inch (1.5 mm) (switch open). Readjust as required.

Removal

- A. Disconnect black\white wires at the switch from the brown wires leading from the Interlock module.
- B. Remove adjusting nut from the plunger side of the switch. Remove switch from bracket.

Installation

- A. Place switch into bracket with one adjusting nut and the plunger end facing the clutch lever. Thread remaining adjustment nut onto the switch.
- B. Adjust switch as necessary.
- C. Connect black\white wires at the switch to the brown wires from the interlock module.

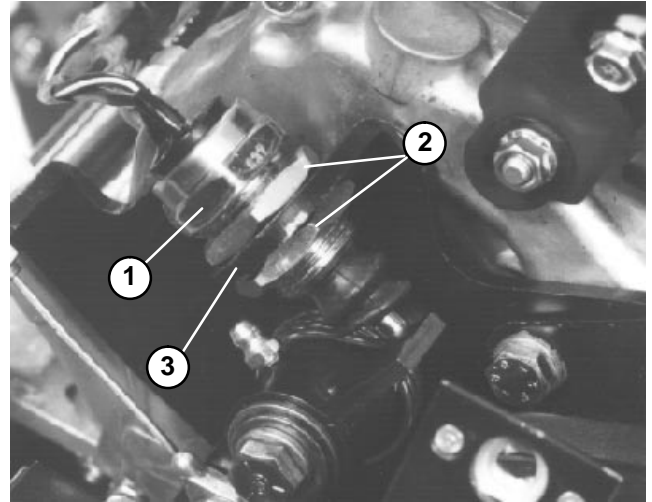

Figure 8

1. Interlock switch
2. Adjusting nut
3. Bracket

Operator Presence Control Switch

Adjustment

1. Make sure the engine is OFF.
2. Loosen both switch adjusting nuts. While holding the bail against the handle, move switch until the switch plunger is depressed 0.16 inch (4.1 mm) (switch closed).
3. Tighten switch mounting nuts.
4. Engage traction lever and verify that the switch plunger is depressed no more than 0.06inch (1.5 mm) (switch open). Readjust as required.

Removal

- A. Disconnect black\white wires at the switch from the brown wires leading from the wire harness.
- B. Remove adjusting nut from the plunger side of the switch. Remove switch from bracket.

Installation

- A. Place switch into bracket with one adjusting nut and the plunger end facing the bail contact tab. Thread remaining adjustment nut onto the switch.
- B. Adjust switch as necessary.
- C. Connect black\white wires at the switch to the brown wires from the wire harness.

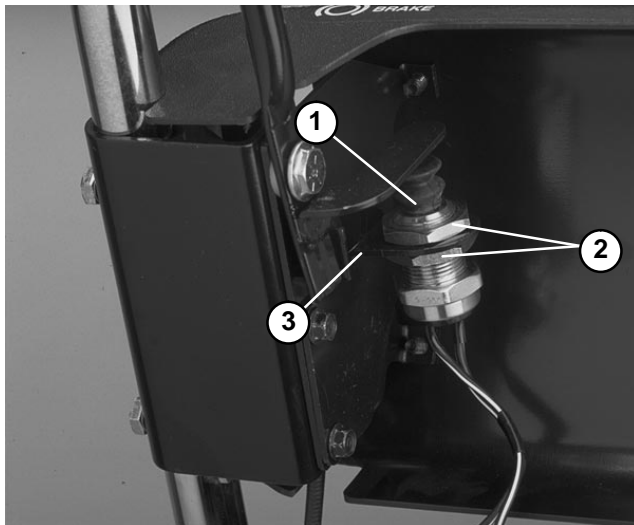

Figure 9

- | | |
|-----------------------------|------------------|
| 1. Operator presence switch | 2. Adjusting nut |
| | 3. Bracket |

Spark Plug

Use a **NGK BPR 5ES** spark plug or equivalent. Remove plug after every 100 operating hours and check its condition.

1. Make sure engine is OFF. Pull high tension lead off the spark plug.
2. Clean around spark plug and remove plug from the cylinder head.

Note: The condition of the spark plug can give an accurate picture of the overall condition of the engine. Use the chart on the following page as a guide to determine possible problems with the engine.

3. Inspect the spark plug.

IMPORTANT: Replace a cracked, fouled, or dirty spark plug. Do not sand blast, scrape, or clean electrodes because engine damage could result from grit entering cylinder.

4. Set air gap at 0.028 to 0.031 inch (0.7 to 0.8 mm). Install correctly gapped spark plug and torque to 20 ft-lb (2.8 kg-m).

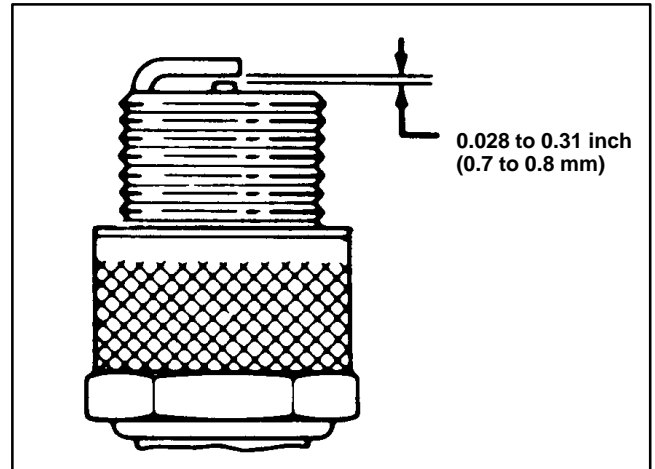
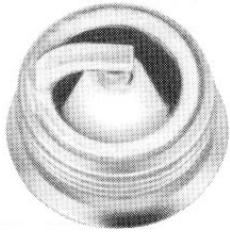
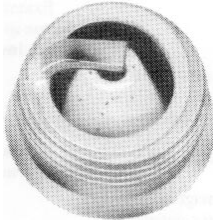

Figure 10



NORMAL

Has gray or light tan deposits on the firing tip.



OVER HEATING

Light gray or white insulator with small gray brown or black spots. Electrodes have a bluish burnt appearance.

May be caused by engine over heating, loose spark plugs, wrong fuel type, too hot a plug, low fuel pump pressure, or incorrect ignition timing.

Replace spark plug.

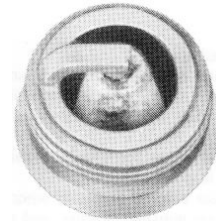

FUSED SPOT DEPOSIT

Has spotty or melted deposits resembling blisters or bubbles.

Caused by sudden acceleration.

Replace spark plug.

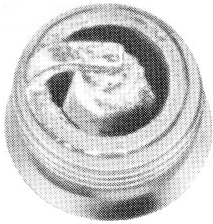

LEAD FOULED

Has dark black, gray, tan, or yellow deposits. May have a fused glazed coating on the insulator tip.

Caused by highly leaded gasoline.

Replace the plug.

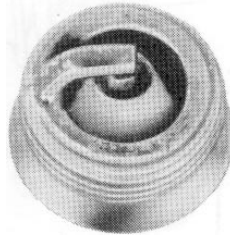

CARBON FOULED

Black dry fluffy carbon deposits are found on insulator tips, electrodes, and exposed shell surfaces.

Weak ignition, too cold a plug, fuel mixture too rich, defective fuel pump, excessive idling, or improperly operating heat riser may be the cause.

Replace spark plug.

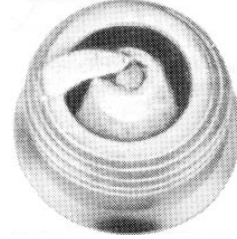

WORN

Has a severely eroded or worn electrode.

Caused by normal wear.

Replace spark plug.



GAP BRIDGED

Gap between electrodes is closed by deposit build up.

May be caused by carbon or oil fouling.

Replace spark plug.

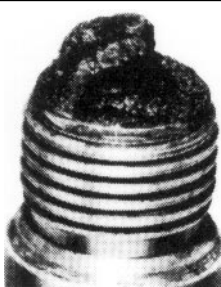

OIL FOULED

Wet black deposits can be found on electrodes, insulator, and in the bore.

Excessive oil entering the combustion chamber through excessive clearances between valve guides and stems, worn or loose bearings, or worn rings and pistons.

Replace spark plug.

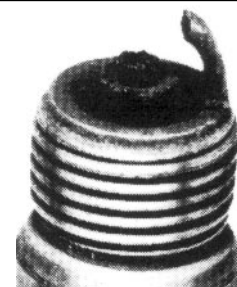

PRE-IGNITION

Electrodes are melted and the insulator may be blistered. Metallic deposits on the insulator indicate engine damage.

Engine over heating, burnt valves, too hot a plug, incorrect ignition timing or advance, or wrong type of fuel are causes.

Replace spark plug.



Controls, Wheels and Accessories

Table of Contents

SPECIFICATIONS	2	Brake Cable Replacement	6
ADJUSTMENTS	3	Clutch Cable Replacement	7
Handle Height Adjustment	3	Throttle Cable Replacement	8
SERVICE AND REPAIRS	4	Wheels	9
Handle Assembly	4	Kickstand	11

Specifications

Item	Description
Tire pressure	12 to 15 PSI, (0.83 to 1.04 bar)
Wheel Shaft torque	65 to 75 ft-lb, (8.99 to 10.37 kg-m)

Adjustments

Handle Height Adjustment

1. Make sure mower is parked on a level surface with the engine OFF.
2. Remove cotter pins from the ring pins on each side of the mower.
3. Support handle, and remove ring pins from each side of the mower. Raise or lower handle to the desired operating position.
4. Reinstall ring pins and cotter pins.

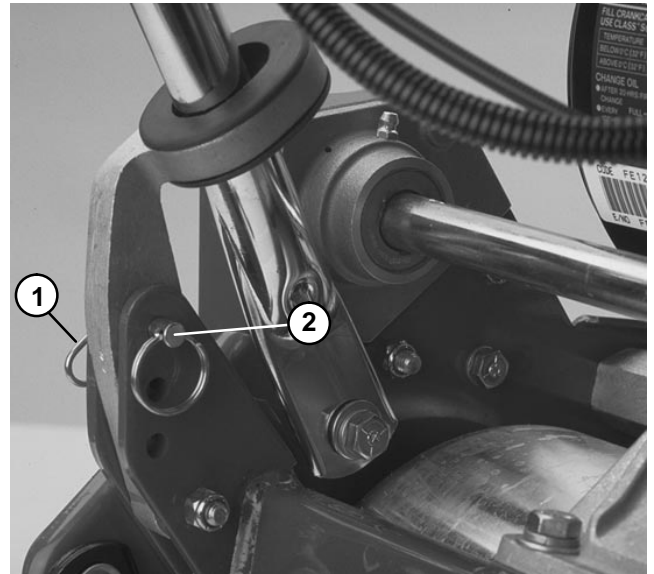

Figure 1

1. Cotter pin

2. Ring pin

Service and Repairs

Handle Assembly

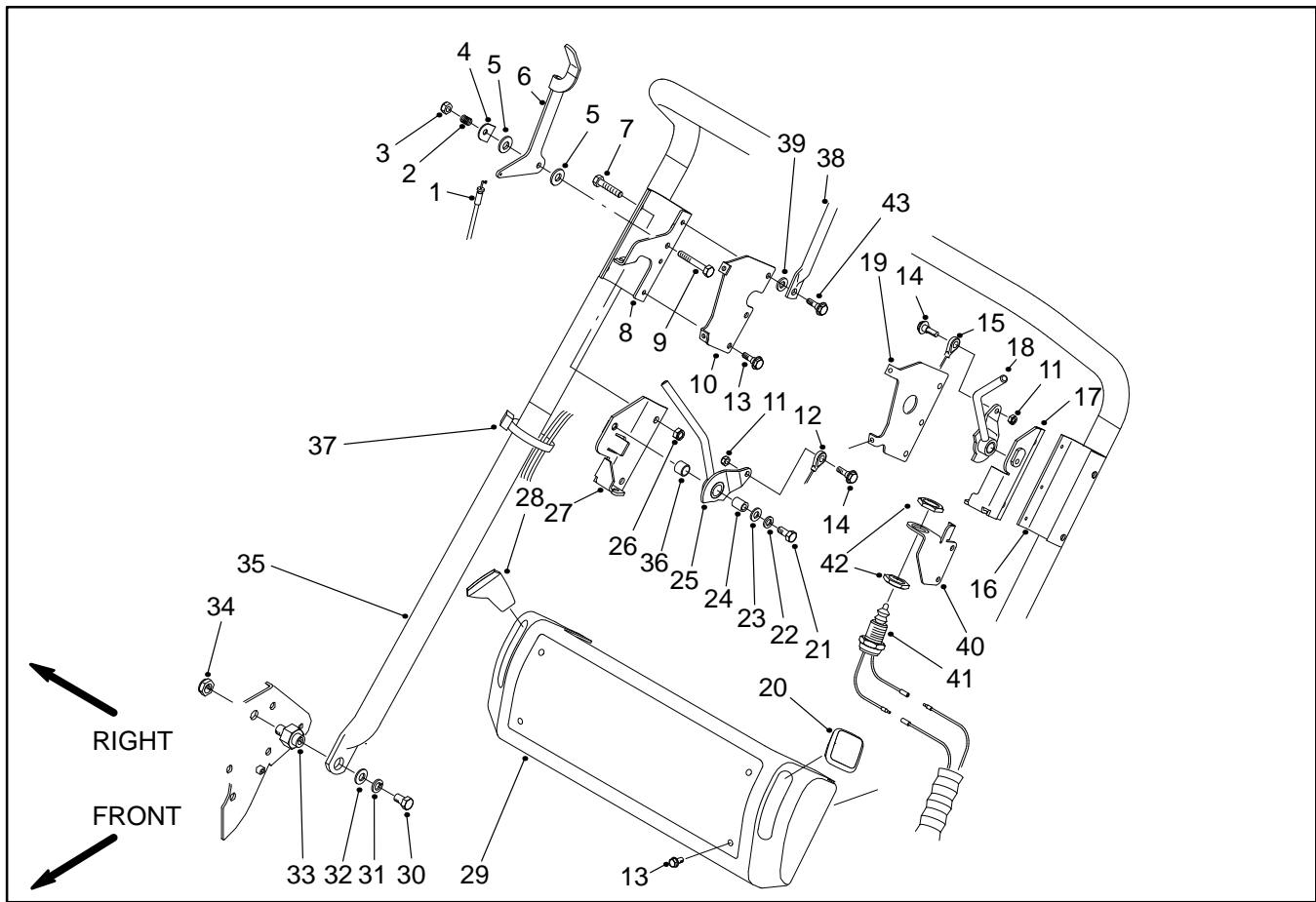

Figure 2

- | | | |
|--------------------------|--------------------------|-----------------------------|
| 1. Throttle cable | 16. Brake skid bracket | 30. Cap screw |
| 2. Spring | 17. Brake bracket | 31. Spring lock washer |
| 3. Lock nut | 18. Brake lever | 32. Flat washer |
| 4. Retaining washer | 19. Console bracket (LH) | 33. Handle pivot pin |
| 5. Friction washer | 20. Red knob | 34. Lock insert nut |
| 6. Throttle lever | 21. Cap screw | 35. Handle |
| 7. Cap screw | 22. Spring lock washer | 36. Bushing |
| 8. Clutch skid bracket | 23. Flat washer | 37. Cable tie |
| 9. Cap screw | 24. Spacer | 38. Bail assembly (Europe) |
| 10. Console bracket (RH) | 25. Clutch lever | 39. Spacer (Europe) |
| 11. Lock nut | 26. Lock nut | 40. Switch bracket (Europe) |
| 12. Clutch cable | 27. Clutch bracket | 41. Switch (Europe) |
| 13. Screw | 28. Black knob | 42. Jam nut (Europe) |
| 14. Shoulder bolt | 29. Console | 43. Shoulder bolt (Europe) |
| 15. Brake cable | | |

Note: Items 38 through 43 above are part of the optional Operator Presence Kit, which presently comes on all models sold in Europe.

Removal

1. Park mower on a level surface. Make sure engine is OFF.
2. Cut cable ties from the handle.
3. Remove cap screw (30), spring lock washer (31), and flat washer (32) from each handle pivot pin (33) on each of the handle (35) ends (Fig. 2 and 3).

Note: The cotter pin, ring pin, cap screw, and lock nut may have to be removed from the handle arms to allow handle removal (Fig. 4).

4. Squeeze handle ends inward. Remove handle ends from the handle pivot pins; pull handle ends clear of the holes in the handle arms (Fig. 3).

Installation

Note: The cotter pin, ring pin, cap screw, and lock nut may have to be removed from the handle arms to allow handle installation (Fig. 4).

1. Slide handle ends through the holes in the handle arms. Squeeze handle ends inward. Install handle ends to the handle pivot pins (33) on each side of the frame. (Fig. 2 and 3).
2. If the cotter pin, ring pin, cap screw, and lock nut have been removed from the handle arms, reinstall the handle arms to the frame. Make sure spacer is installed in the handle arm. (Fig. 4).
3. Install cap screw (30), spring lock washer (31), and flat washer (32) to each handle pivot pin (33) on each of the handle (35) ends (Fig. 2 and 3).
4. Secure cables to the handle with new cable ties.

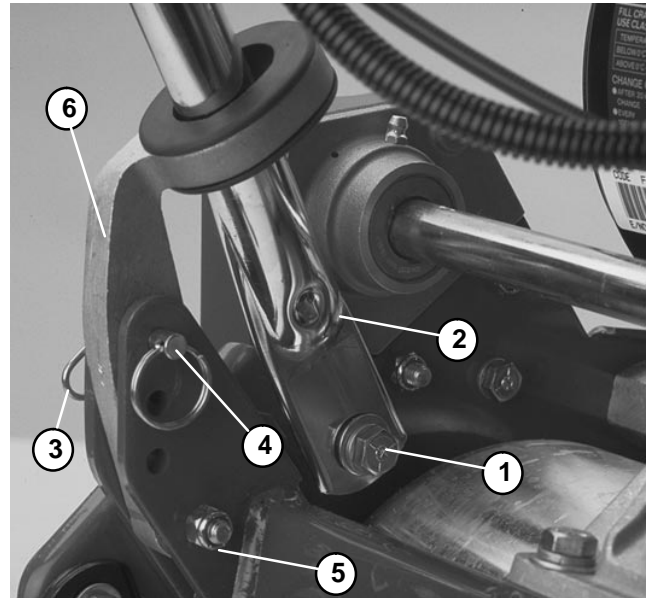

Figure 3

- | | |
|------------------------|---------------|
| 1. Cap screw & washers | 4. Ring pin |
| 2. Handle end | 5. Lock nut |
| 3. Cotter pin | 6. Handle arm |

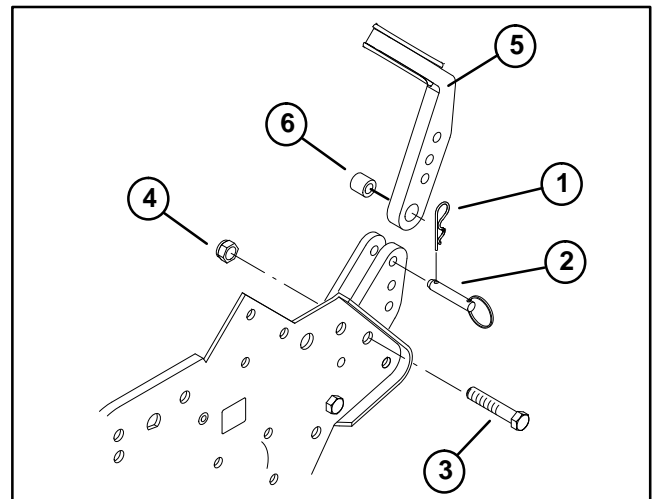

Figure 4

- | | |
|---------------|---------------|
| 1. Cotter pin | 4. Lock nut |
| 2. Ring pin | 5. Handle arm |
| 3. Cap screw | 6. Spacer |

Brake Cable Replacement

Removal

1. Park mower on a level surface. Make sure engine is OFF. Remove high tension lead from the spark plug.
2. Disengage brake to release tension on the brake cable. Remove cable ties from the left side of the handle.
3. Remove brake cable from the countershaft housing as follows (Fig. 5):

- A. Open bellcrank cover to access the brake lever.
- B. Remove shoulder bolt and lock nut from the brake lever and cable eyelet.
- C. Loosen rear nut attaching the brake cable to the countershaft housing. Remove brake cable from housing and brake lever

4. Make sure brake is disengaged and the clutch is engaged so the console (29) can be positioned to access the brake lever (18) and brake cable (15) (Fig. 2).

5. Remove four screws (13) securing the console (29) to the console brackets (10 and 19). Position console forward and away from the brackets (Fig. 2).

Note: On models without the operator presence kit, the bail assembly, switch, and switch bracket are not installed on the handle assembly. The shoulder bolt and spacer are substituted by an additional screw on both sides of the handle assembly (Fig. 2 and 6).

6. Gain access to the brake lever and brake cable as follows (Fig. 6):

- A. If the operator presence kit is installed, remove both screws and switch bracket (with switch attached) from the brake skid bracket. Remove shoulder bolt and spacer from the bail assembly and brake skid bracket. Remove console bracket from the brake skid bracket.

- B. If the operator presence kit is **not** installed, remove three screws and console bracket from the brake skid bracket.

7. Remove shoulder bolt (14) and lock nut (11) from the brake lever (18) and brake cable (15) eyelet (Fig. 2).

8. Loosen nut securing the brake cable (15) to the brake bracket (17). Remove cable from the bracket. Remove brake cable from the mower.

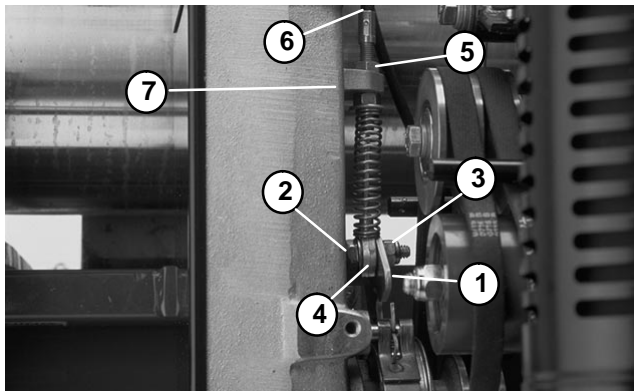

Figure 5

- | | |
|------------------|-------------------------|
| 1. Brake lever | 5. Rear nut |
| 2. Shoulder bolt | 6. Brake cable |
| 3. Lock nut | 7. Countershaft housing |
| 4. Cable eyelet | |

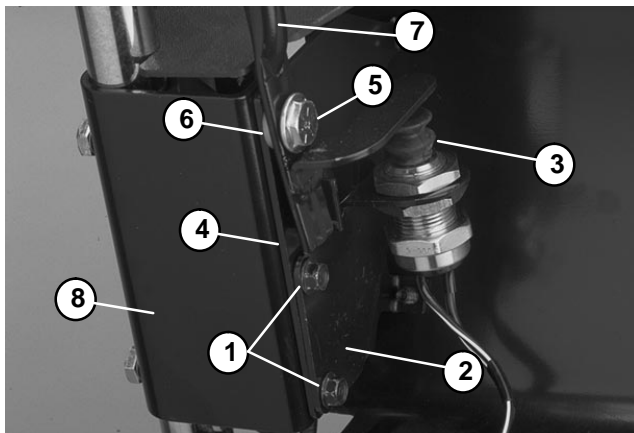

Figure 6

- | | |
|--------------------|-----------------------|
| 1. Screw | 5. Shoulder bolt |
| 2. Switch bracket | 6. Spacer |
| 3. Switch | 7. Bail assembly |
| 4. Console bracket | 8. Brake skid bracket |

Installation

1. Secure brake cable (15) eyelet to the brake lever (18) with the shoulder bolt (14) and lock nut (11) (Fig. 2).

Note: On models without the operator presence kit, the bail assembly, switch, and switch bracket are not installed on the handle assembly. The shoulder bolt and spacer are substituted by an additional screw on both sides of the handle assembly (Fig. 2 and 6).

2. Reinstall bail assembly and brackets. (Fig. 6).

- A. If the operator presence kit is installed, reinstall console bracket and switch bracket (with switch attached) to the brake skid bracket. Secure brackets with both screws. Secure bail assembly and spacer, to the brake skid bracket with the shoulder bolt.

- B. If the operator presence kit is **not** installed, secure console bracket to the brake skid bracket with three screws.
3. Position console (29) over the console brackets (10 and 19). Secure console to both brackets with four screws (13) (Fig. 2).
 4. Run new brake cable to the countershaft assembly. Install new brake cable to the countershaft housing and brake lever as follows (Fig. 5):
 - A. Attach brake cable to the counter shaft housing and tighten the rear nut.
 - B. Secure cable eyelet to the brake lever with shoulder bolt and lock nut.
 5. Install new cable ties to the left side of the handle.
 6. Adjust brake cable and close bellcrank cover (see Service/Park Brake Adjustment in Chapter 7 – Traction and Reel Drive Systems).

Clutch Cable Replacement

Removal

1. Park mower on a level surface. Make sure engine is OFF. Remove high tension lead from the spark plug.
2. Disengage clutch to release tension on the clutch cable. Remove cable ties from the right side of the handle.
3. Remove clutch cable from the bellcrank assembly as follows (Fig. 7):
 - A. Open bellcrank cover to access the clutch lever and bracket.
 - B. Remove shoulder bolt and lock nut securing the cable eyelet to the clutch lever.
 - C. Loosen rear nut attaching the clutch cable to the clutch bracket. Remove clutch cable from the clutch bracket.
4. Make sure brake is disengaged and the clutch is engaged so the console (29) can be positioned to access the clutch lever (25) and clutch cable (12) (Fig. 2).
5. Remove four screws (13) securing the console (29) to the console brackets (10 and 19). Position console forward and away from the brackets (Fig. 2).

Note: On models without the operator presence kit, the bail assembly is not installed on the handle assembly. The shoulder bolt and spacer are substituted by an additional screw on both sides of the handle assembly (Fig. 2 and 8).

6. Gain access to the clutch lever and clutch cable as follows (Fig. 8):
 - A. If the operator presence kit is installed, remove both screws from clutch skid bracket. Remove shoulder bolt and spacer from the bail assembly and clutch skid bracket. Remove console bracket from the clutch skid bracket.
 - B. If the operator presence kit is **not** installed, remove three screws and console bracket from the clutch skid bracket.
7. Remove shoulder bolt (14) and lock nut (11) from the clutch lever (25) and clutch cable (12) eyelet (Fig. 2).
8. Loosen nut securing the clutch cable (12) to the clutch bracket (27). Remove cable from the clutch bracket (Fig. 2).
9. Remove clutch cable from the mower.

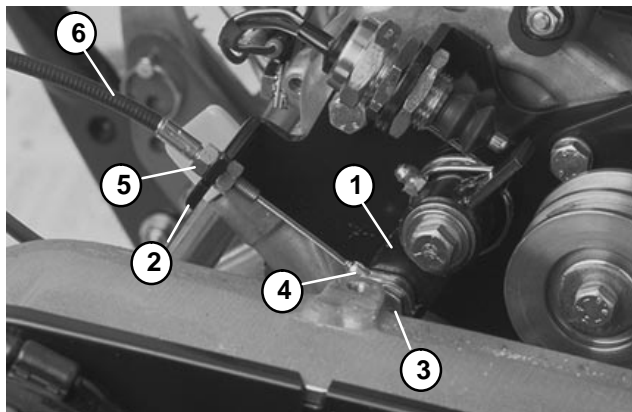

Figure 7

- | | |
|-----------------------------|-----------------|
| 1. Clutch lever | 4. Cable eyelet |
| 2. Clutch bracket | 5. Rear nut |
| 3. Shoulder bolt & lock nut | 6. Clutch cable |

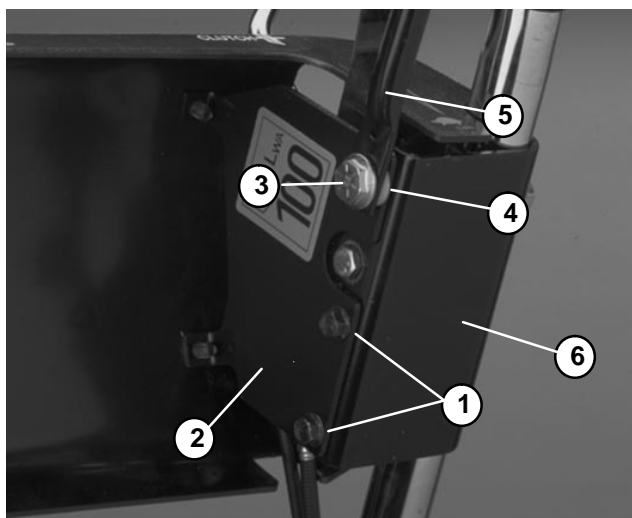

Figure 8

- | | |
|--------------------|------------------------|
| 1. Screw | 4. Spacer |
| 2. Console bracket | 5. Bail assembly |
| 3. Shoulder bolt | 6. Clutch skid bracket |

Installation

1. Secure clutch cable (12) eyelet to the clutch lever (25) with the shoulder bolt (14) and lock nut (11) (Fig. 2).

Note: On models without the operator presence kit, the bail assembly is not installed on the handle assembly. The shoulder bolt and spacer are substituted by an additional screw on both sides of the handle assembly (Fig. 2 and 8).
2. If the operator presence kit is installed, reinstall console bracket to the clutch skid bracket. Secure brackets with both screws. Secure bail assembly and spacer to the clutch skid bracket with the shoulder bolt (Fig. 8).

3. If the operator presence kit is **not** installed, secure console bracket to the clutch skid bracket with three screws (Fig. 8).
4. Position console (29) over both console brackets (10 and 19). Secure console to the brackets with four screws (13) (Fig. 2).
5. Run new clutch cable to the bellcrank assembly. Install new cable to the clutch lever as follows (Fig. 7).
 - A. Attach clutch cable to the clutch bracket. Tighten nut to secure cable to the bracket.
 - B. Secure clutch cable eyelet to the clutch lever with shoulder bolt and lock nut.
6. Install new cable ties to the right side of the handle.
7. Adjust clutch cable and close bellcrank cover (see Clutch Control Adjustment in Chapter 3 – Engine).

Throttle Cable Replacement

Removal

1. Park mower on a level surface. Make sure engine is OFF. Remove high tension lead from the spark plug.

2. Remove cable ties from the right side of the handle. Remove nut and cable clip from the flangette on the countershaft housing.

3. Remove throttle cable from the governor as follows (Fig. 9):

A. Unscrew throttle cable screw enough to release the throttle cable from the nut in the governor lever.

B. Remove hex head screw from the throttle cable bracket.

C. Pull throttle cable clear of the nut in the governor lever.

4. Make sure brake is disengaged and the clutch is engaged so the console (29) can be positioned to access the throttle lever (6) and throttle cable (1) (Fig. 2).

5. Remove four screws (13) securing the console (29) to the console brackets (10 and 19). Position console forward and away from the brackets (Fig. 2).

6. Gain access to the throttle lever and throttle cable as follows (Fig. 10):

A. Remove both screws from clutch skid bracket.

B. Remove shoulder bolt and spacer from the bail assembly and clutch skid bracket. Remove console bracket from the clutch skid bracket.

7. Snap throttle cable (1) out of the clutch skid bracket (8). Disconnect throttle cable from the throttle lever (6) (Fig. 2).

8. Remove clutch cable from the mower.

Installation

1. Connect throttle cable (1) to the throttle lever (6). Snap throttle cable to the clutch skid bracket (8) (Fig. 2).

2. Reinstall console bracket to the clutch skid bracket. Secure brackets with both screws (Fig. 10).

3. Secure bail assembly and spacer to the clutch skid bracket with the shoulder bolt (Fig. 10).

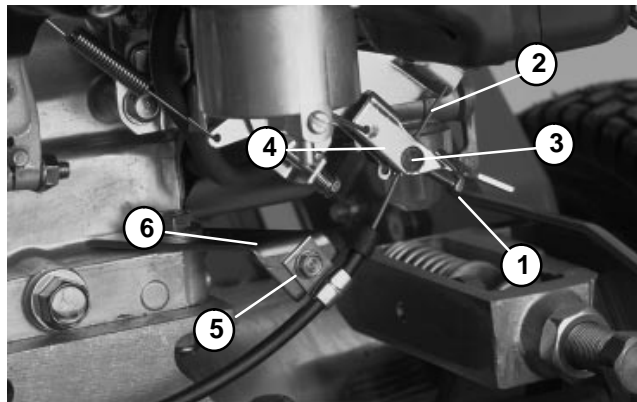

Figure 9

- | | |
|-------------------------|---------------------------|
| 1. Throttle cable screw | 4. Governor lever |
| 2. Throttle cable | 5. Hex head screw |
| 3. Nut | 6. Throttle cable bracket |

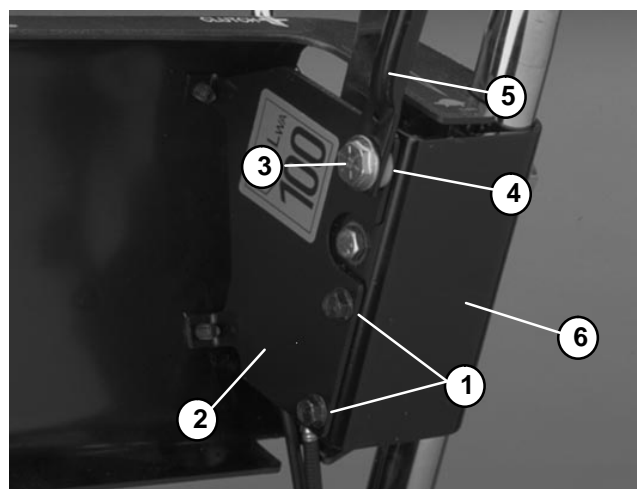

Figure 10

- | | |
|--------------------|------------------------|
| 1. Screw | 4. Spacer |
| 2. Console bracket | 5. Bail assembly |
| 3. Shoulder bolt | 6. Clutch skid bracket |

4. Position console (29) over both console brackets (10 and 19). Secure console to the brackets with four screws (13) (Fig. 2).

5. Run new throttle cable to the governor lever. Install new cable to the governor lever as follows (Fig. 9).

A. Insert throttle cable into the nut.

B. Tighten throttle cable screw to hold cable in the nut and governor lever. Do not tighten screw.

6. Install new cable ties to the right side of the handle. Secure throttle cable to the flangette on the countershaft housing with the cable clip and nut.

7. Adjust throttle cable (see Throttle Linkage Adjustment in Chapter 3 – Engine).

Wheels

Removal

1. Park mower on a level surface. Make sure the engine is OFF.
2. Push kickstand down with one foot while pulling up on the handle. This will support the mower on the kick stand.
3. Pivot wheel locking clip away from the center of the wheel. Slide wheel off the wheel shaft.

Note: The right hand wheel shaft has left hand threads.

4. If necessary, remove wheel shaft from the drive pulley.

Installation

1. Make sure mower is parked on a level surface and the engine is OFF.
2. Push kickstand down with one foot while pulling up on the handle. This will support the mower on the kick stand.

Note: The right hand wheel shaft has left hand threads.

3. If the wheel shafts were removed from the drive pulleys,
 - A. Apply Loctite 242 or equivalent to the threads of the wheel shafts.

IMPORTANT: The right hand wheel shaft has left hand threads.

Note: The drum shafts inboard of the side plates have flats that can be used while torquing the wheel shafts.

- B. Install right hand wheel shaft into the drive pulley on the right side of the mower. Install the remaining shaft. Torque both shafts from 65 to 75 ft-lb (9.0 to 10.3 kg-m).
4. Apply anti-seize lubricant to the exposed end of the wheel shaft.
 5. Slide wheel onto the wheel shaft.
 - A. Pivot wheel locking clip away from the center of the wheel.
 - B. Allow wheel to slide onto the shaft until the locking clip is secured into the groove on the wheel shaft.

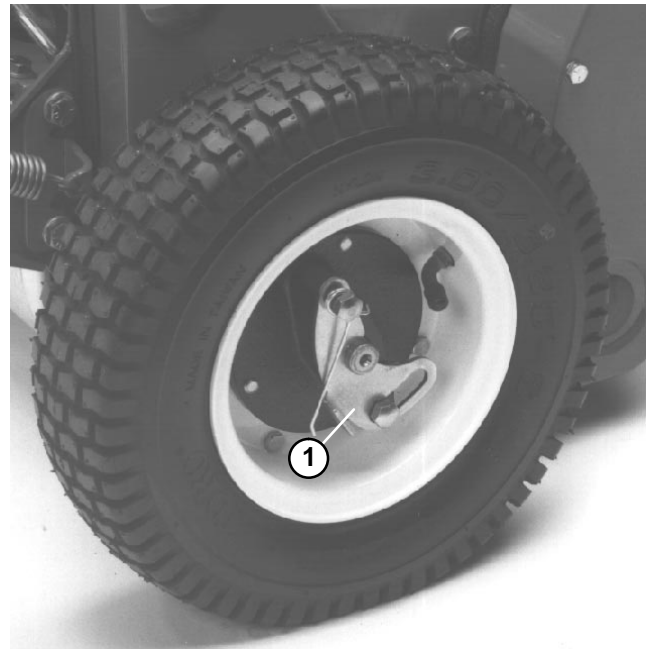

Figure 11

1. Locking clip

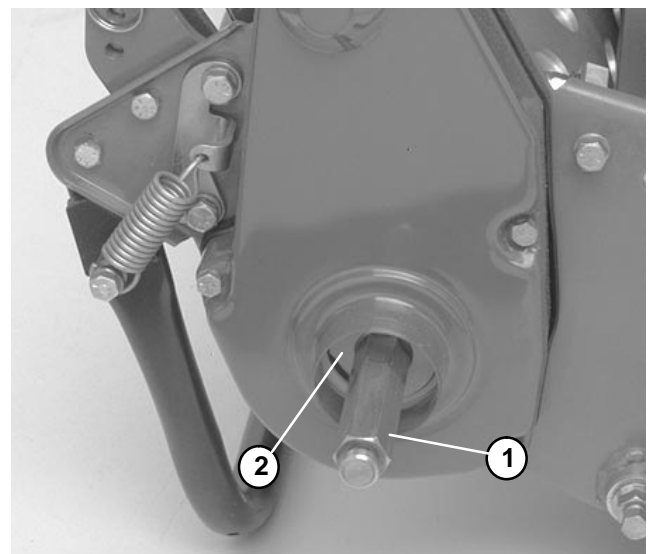

Figure 12

1. Wheel shaft

2. Drive pulley

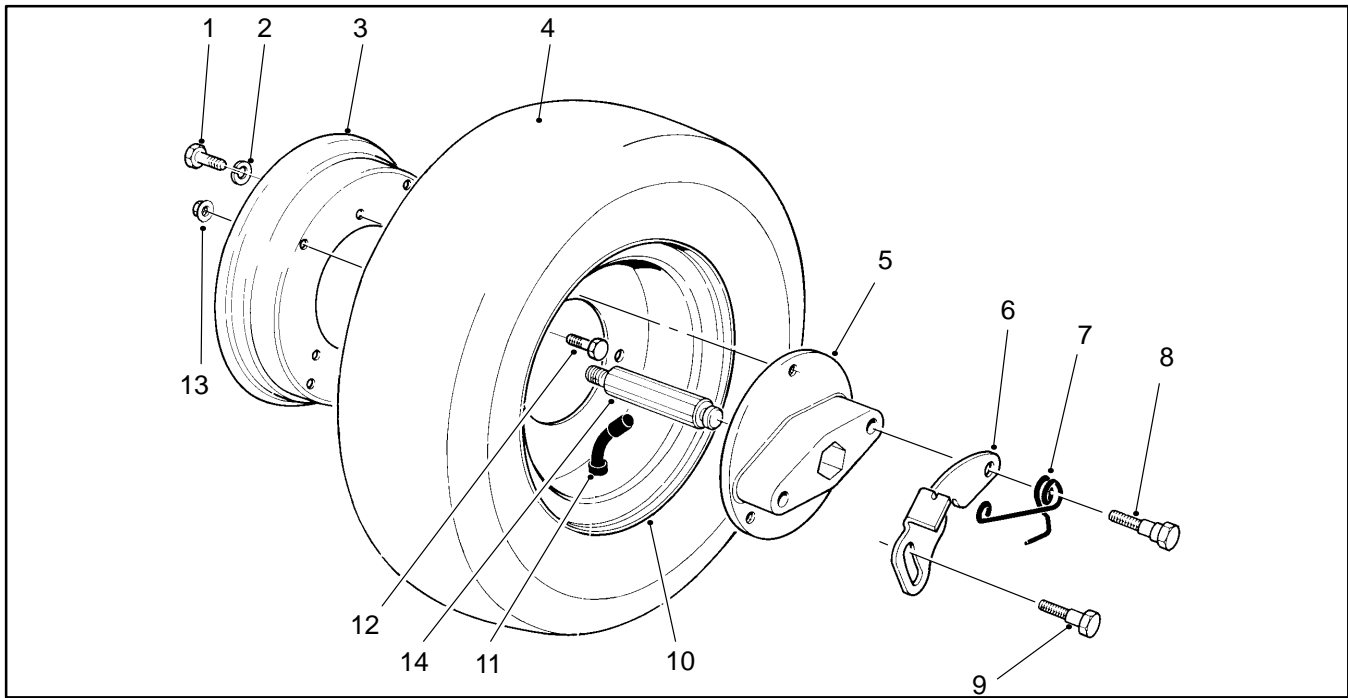

Figure 13

- 1. Cap screw
- 2. Lock washer
- 3. Shallow rim
- 4. Tire
- 5. Hub

- 6. Retaining lever
- 7. Spring
- 8. Bolt
- 9. Bolt
- 10. Deep rim

- 11. Inner tube
- 12. Cap screw
- 13. Flange nut
- 14. Wheel shaft

Disassembly

1. Remove three cap screws (1) and lock washers (2) from the shallow rim (3) and hub (5). Remove hub from deep rim (10).
2. Remove four cap screws (12) and flange nuts (13) from the deep rim (10) and shallow rim (3). Remove shallow rim from the deep rim.
3. Remove bolt (9) from the hub (5). Remove bolt (8), spring (7), and retaining lever (6) from the hub.

Reassembly

1. Reinstall retaining lever (6), spring (7), and bolt (8) to the hub (5). Reinstall bolt (9) to the hub. Tighten both bolts
2. Reinstall shallow rim (3) into the deep rim (10). Secure shallow rim to the deep rim with the four cap screws (12) and flange nuts (13). Tighten fasteners.
3. Reinstall hub (5) into deep rim (10). Secure hub to deep rim with three cap screws (1) and lock washers (2). Tighten fasteners.

Kickstand

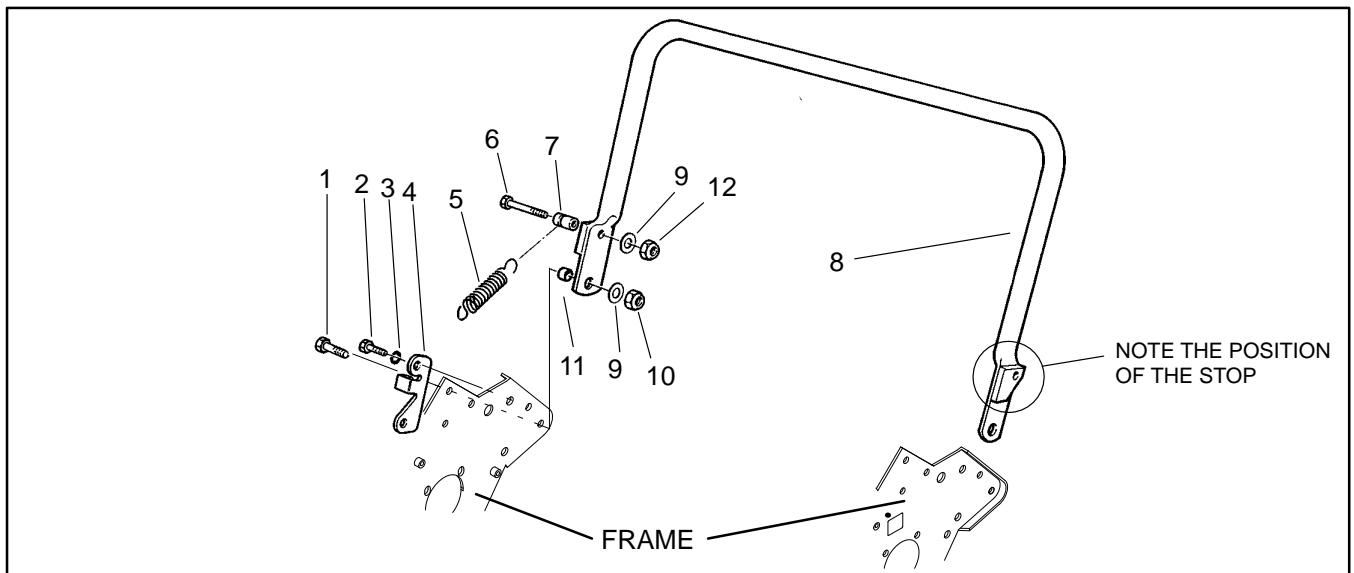

Figure 14

- 1. Cap screw
- 2. Cap screw
- 3. Lock washer
- 4. Spring bracket

- 5. Extension spring
- 6. Cap screw
- 7. Spring retainer
- 8. Kickstand

- 9. Flat washer
- 10. Lock nut
- 11. Spacer
- 12. Flange lock nut

Removal

1. Park mower on a level surface. Make sure the engine is OFF.
2. Pivot kickstand up against the handle and hold there.
3. Use a pliers to remove the extension spring from the spring retainer (Fig. 15).
4. Remove both lock nuts (10), flat washers (9), cap screws (1), and spacers (11) from the kickstand (8) and frame. Remove kickstand from the frame (Fig. 14).

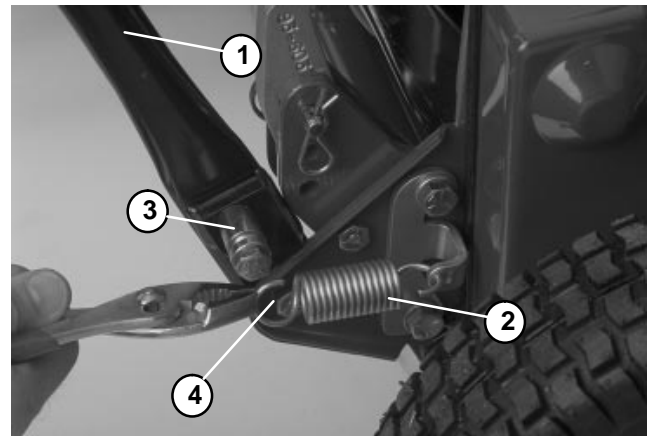

Figure 15

- 1. Kickstand
- 2. Extension spring

- 3. Spring retainer
- 4. Cap screw

Installation

1. Make sure mower is parked on a level surface and the engine is OFF.
2. Position kickstand (8) inside the mower frame. Insert capscrews (1) through the frame, spacers (11), and kickstand (Fig. 14).
3. Secure cap screws (1) with flat washers (9) and lock nuts (10). Tighten fasteners (Fig. 14).
4. Pivot kickstand up against the handle and hold there. Use a pliers to reinstall the extension spring to the spring retainer (Fig. 15).



Table of Contents

INTRODUCTION	2	SERVICE AND REPAIRS	13
SPECIFICATIONS	3	Backlapping	13
GENERAL INFORMATION	4	Lubrication	13
Grass Basket Installation	4	Bedbar	14
SPECIAL TOOLS	5	Bedknife Replacement and Grinding	16
TROUBLESHOOTING	7	Roller	17
Factors Affecting Quality of Cut	7	Roller Bearing Replacement	17
ADJUSTMENTS	9	Reel	18
Leveling Drum to Reel	9	Preparing Reel for Grinding	20
Bedknife to Reel Adjustment	10		
Height-of-Cut Adjustment	11		
Grass Shield Height Adjustment	12		
Cutoff Bar Adjustment	12		

Introduction

This Chapter covers the cutting unit section of the GR1000. The cutting unit consists of the frame assembly, reel assembly, drum assembly, and detachable basket. The reel and drum drive assemblies make up **part**

of the cutting unit, and their component parts that are necessary for the service of the cutting unit are covered in this chapter.

Specifications



Figure 1

REEL CONSTRUCTION (GR1000): 5-inch (12.7 cm) diameter, 11 carbon steel blades (optional 8 blades) welded to 5 stamped steel spiders.

HEIGHT-OF-CUT RANGE (GR1000): 5/64 to 1 inch (2 to 25 mm)

WIDTH-OF-CUT (GR1000): 21 inches (53.3 cm)

CLIP (GR1000): 0.16 inch (0.41 cm)

REEL CONSTRUCTION (GR1600): 5-inch (12.7 cm) diameter, 8 carbon steel blades welded to 6 stamped steel spiders.

HEIGHT-OF-CUT RANGE (GR100): 1/8 to 1-1/4 inch (3 to 32 mm)

WIDTH-OF-CUT (GR1600): 26 inches (66.0 cm)

CLIP (GR1600): 0.23 inch (0.58 cm)

BEDKNIFE AND BEDBAR: Single edged high carbon steel bedknife, hardened to RC 48-54. A cast iron bedbar is fastened to the mower. Tournament bedknife (Part No. 93-4263) is standard.

General Information

Grass Basket Installation

1. Grasp basket by top rear lip and slide on or off the basket mounting rods.

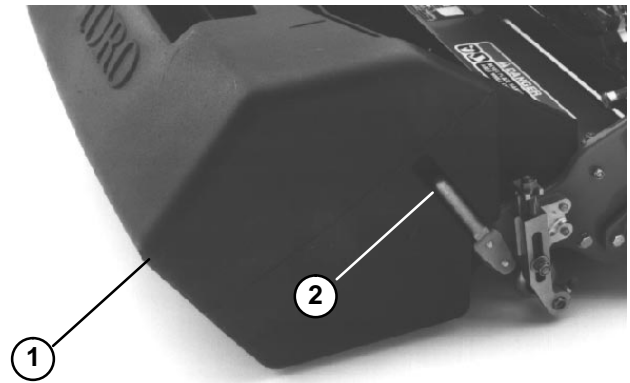

Figure 2

1. Grass basket

2. Mounting rod

Special Tools

Order special tools from the *TORO SPECIAL TOOLS AND APPLICATIONS GUIDE (COMMERCIAL PRODUCTS)*.

Some tools may have been supplied with your mower or available as TORO parts. Some tools may also be available from a local supplier.

Gauge Bar Assembly – P/N 13–8199

Used to verify height-of-cut.

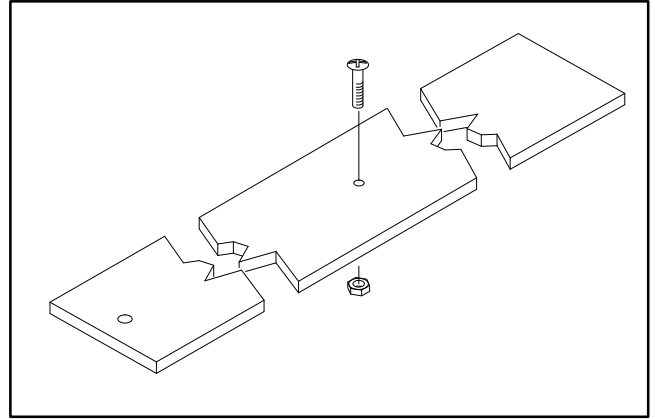

Figure 3

Backlapping Brush Assembly – TOR299100

Used to apply lapping compound to cutting units while keeping the operator's hands at a safe distance from the rotating reel.

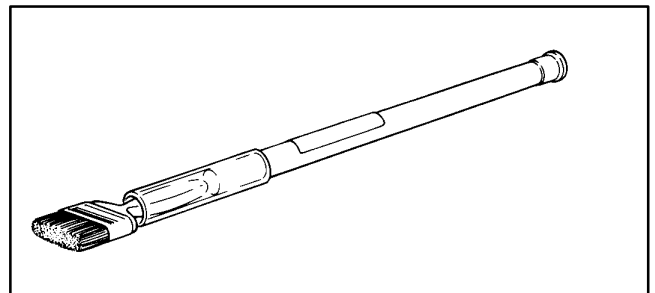

Figure 4

Bedknife Screw Tool – TOR510880

This screwdriver-type bit is made to fit Toro bedknife attaching screws. Use this bit with a torque wrench to secure the bedknife to the bedbar.

DO NOT use an air or manual impact wrench with this tool.

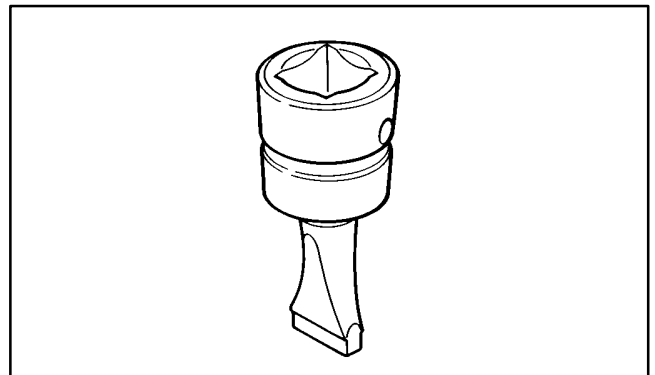

Figure 5

Bearing Replacement Tool Kit – TOR238900A

The puller is used to remove the bearings from the rollers. A driving tube is used to install bearings into the roller. A drill bushing is used to drill into bearing shafts without a removal hole.

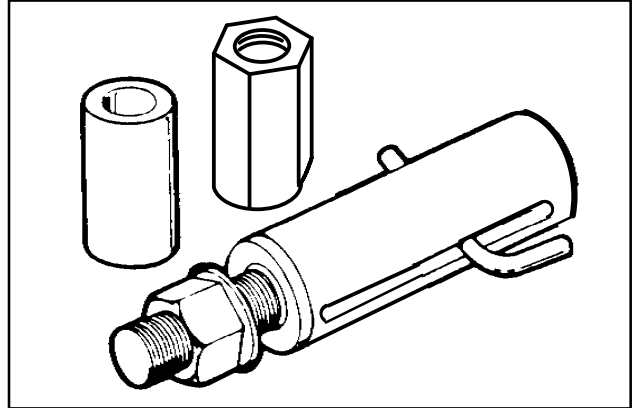

Figure 6

Troubleshooting

There are a number of factors that can contribute to unsatisfactory quality of cut, some of which may be turf conditions. Turf conditions such as excessive thatch, “sponginess” or attempting to cut off too much grass height may not always be overcome by adjusting the

mower. It is important to remember that the lower the height-of-cut, the more critical these factors are. See Adjustments and Service and Repairs sections for detailed adjustments and repair information.

Factors That Can Affect Quality of Cut

Factor	Possible Problem/Correction
Governed engine speed	<p>Check maximum governed engine speed. Adjust engine to specifications if necessary.</p> <p>See Adjustments section in Chapter 3 – Engine.</p>
Reel bearing condition	<p>Check and replace bearings if necessary. Make sure bearing housings are secured properly.</p> <p>See Reel and Reel Bearings in the Service and Repairs section.</p>
Reel and bedknife sharpness	<p>A reel and/or bedknife that has rounded cutting edges or “rifling (grooved or wavy appearance) cannot be corrected by tightening the bedknife to reel contact. Grind reel to remove taper and/or rifling. Grind bedknife to sharpen and/or remove rifling.</p> <p>The most common cause of rifling is bedknife to reel contact that is too tight.</p> <p>A new bedknife must be ground or backlapped after installation to the bedbar.</p>
Bedknife to reel adjustment	<p>Check bedknife to reel contact daily. The bedknife must have light contact across the entire reel. No contact will dull the cutting edges. Excessive contact accelerates wear of both edges. Quality of cut is adversely affected by both conditions (see Bedknife to Reel Adjustment).</p> <p>Slightly dull cutting edges may be corrected by backlapping (see Backlapping).</p> <p>Excessively dull cutting edges must be corrected by grinding the reel to and bedknife (see Preparing Reel for Grinding).</p>
Drum parallel to reel	<p>Check and adjust as necessary. The Drum must be leveled so it is parallel with the reel before setting the height-of-cut.</p> <p>See Leveling Rear Drum to Reel in Adjustments section.</p>

Factor	Possible Problem/Correction
Height-of-cut	“Effective” or actual height-of-cut depends on the mower weight and turf conditions. Effective height-of-cut will be different than the bench set height-of-cut.
Proper bedknife for height-of-cut	If the bedknife is too thick for effective height-of-cut, poor quality of cut will result.
Front roller scraper and comb adjustment	Install and/or adjust roller scrapers if grass clippings build up on the rollers. Set clearance between the scraper and roller at 1/32 inch (0.8 mm).
Stability of bedbar	<p>Make sure bedbar pivot bolts are securely seated. Check condition of the bushings in the side plates.</p> <p>See Bedbar in Service and Repairs section.</p>
Number of reel blades	Use correct number of blades for clip frequency and optimum height-of-cut range.
Roller condition	<p>Make sure rollers rotate freely. Grease roller when needed, or repair bearings as necessary.</p> <p>See Roller Bearing Replacement in Service and Repairs section.</p>
Traction speed	<p>Check maximum governed engine speed. Adjust engine to specifications if necessary. The drive belts may be loose or worn. Check the condition of the belts and adjust or replace as necessary.</p> <p>See Adjustments section in Chapter 3 – Engine and Chapter 4 – Traction and Reel Drive System. Also, see Service and Repairs section in Chapter 4.</p>
Grooming reel operation	See Troubleshooting section of Chapter 8 – Grooming Reel Kit.

Adjustments



CAUTION

Never work on the mower with the engine running. Always stop the engine and remove the high tension lead from the spark plug first.

Leveling Drum to Reel

1. Make sure engine is OFF. Remove high tension lead from the spark plug.
2. Position mower on a flat level surface, preferably a precision steel work plate. Place a 1/4-inch x 1-inch flat steel strip, approximately 24 inches long, under the reel blades and against the front edge of the bedknife to prevent the bedbar from resting on the work surface.
3. Raise front roller so only the rear drum and reel are on the surface.
4. Firmly press down on mower above the reel so all reel blades contact the steel strip.
5. While pressing down on reel, slide a feeler gauge under one end of the drum, then check the other end of the drum. If there is a gap between the drum and the work surface, greater than 0.010 inch (0.254 mm), on either end, an adjustment to the drum is required, proceed to step 5. If the gap is less than 0.010 inch (0.254 mm) no adjustment is required.
6. Remove rear belt cover from right side of mower.
7. Rotate drive pulley until holes align with all four roller bearing flange screws (Fig. 7).
8. Loosen all four roller bearing screws and screw securing idler pulley. Raise or lower right side of drum assembly until the gap is reduced to less than 0.010 inch (0.254 mm). Torque drum bearing cap screws from **16 to 20 ft-lbs (2.2 to 2.8 kg-m)** (Fig. 7). Adjust belt tension and tighten idler pulley mounting screw (see Drive Belt in Adjustments section of Chapter 4 – Traction and Reel Drive System).

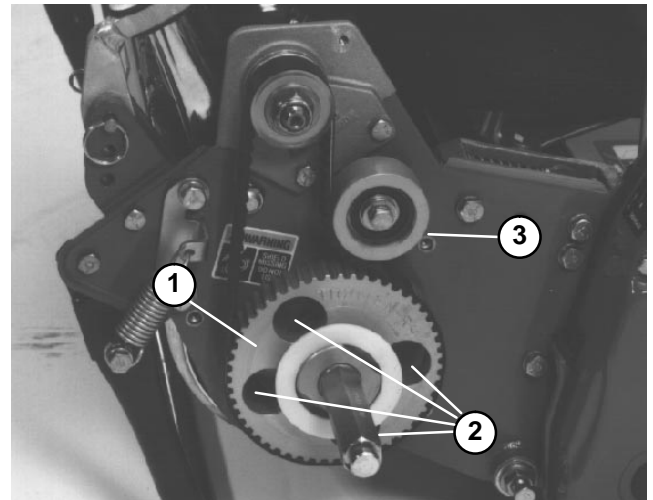

Figure 7

1. Drive pulley
2. Four holes

3. Idler pulley

Bedknife to Reel Adjustment

1. Position mower on a flat level work surface. Make sure engine is OFF. Remove high tension lead from the spark plug. Remove reel contact:

A. On the GR1000, loosen the jam nuts on the bedknife adjusting screws and rotate adjusting screws counterclockwise (Fig. 8).

B. On the GR1600, turn bedbar adjusting screws counterclockwise (Fig. 9).

2. Tilt mower back on handle to expose bedknife and reel.

Note: Each time adjusting screw is rotated one flat on the **GR1000**, the bedknife moves 0.003 inch (0.076 mm) closer to the reel. Each time adjusting screw is rotated one click on the **GR1600**, the bedknife moves 0.0007 inch (0.018 mm) closer to the reel. **DO NOT OVERTIGHTEN ADJUSTING SCREWS.**

3. On one end of the reel do the following (Fig. 10):

A. Insert a long strip of newspaper between the reel and bedknife.

B. On the GR1000, while slowly rotating the reel forward, tighten bedknife adjusting screw one flat at a time until the paper is pinched lightly.

C. On the GR1600, while slowly rotating the reel forward, tighten bedbar adjusting screw clockwise one click at a time until the paper is pinched lightly.

D. When inserted from the front and parallel to the bedknife, a slight drag on the paper should result when the paper is pulled.

4. Check for light contact at the other end of the reel using paper and adjust as required. On the **GR1000**, make sure jam nuts on the adjusting screws are tightened upon completion of the adjustment (Fig. 8).

5. After the adjustment is accomplished, check to see if the reel can pinch a strip of paper when inserted from the front and cut the paper when inserted at a right angle to the bedknife (Fig. 11).

A. It should be possible to cut the paper with minimum contact between the bedknife and the reel blades.

B. Should excessive reel drag of more than 7 in–lb (8 kg–cm) be evident, it will be either necessary to backlap or regrind the reel and bedknife to achieve the sharp edges needed for precision cutting (see TORO Sharpening Reel and Rotary Mowers Manual, Form No. 80-300 PT).

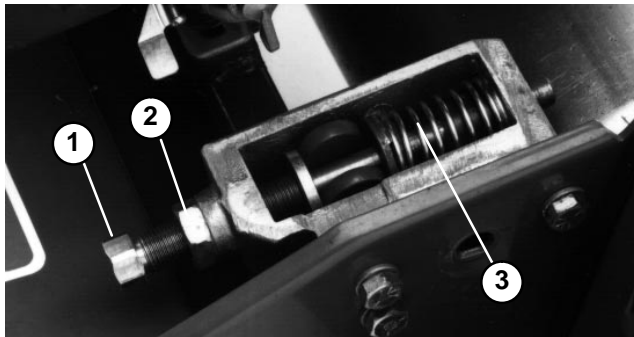
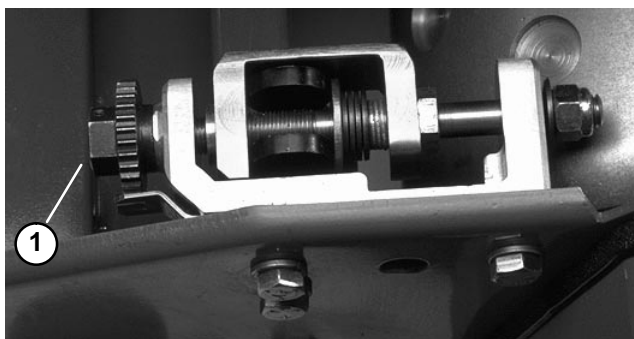

Figure 8

- 1. Jam nut
- 2. Adjusting screw
- 3. Spring



1. Bedbar adjusting screw
Figure 9



Figure 10



Figure 11

Height-of-Cut Adjustment

1. Park mower on a level surface. Make sure engine is OFF. Remove high tension lead from the spark plug.

2. Verify that the drum is level to the reel and that the bedknife to reel contact is correct. Tip mower back on its handle to expose roller, drum, and bedknife.

3. Loosen locknuts securing height-of-cut arms to the height-of-cut brackets (Fig. 13).

4. Loosen nut on gauge bar and set adjusting screw to desired height-of-cut. Distance between bottom of screw head and face of bar is height-of-cut (Fig. 14).

5. Hook adjusting screw head on the cutting edge of the bedknife. Rest the rear end of the bar on the drum (Fig. 15).

6. Rotate height-of-cut screw until the roller contacts the front of the gauge bar. Adjust both ends of the roller until the entire roller is parallel to the bedknife (Fig. 13).

IMPORTANT: When set properly, the roller and drum should contact the gauge bar, and the adjusting screw should be snug against the bedknife. This assures that the height-of-cut is identical at both ends of the bedknife.

7. Tighten both lock nuts to lock the height adjustment (Fig. 13).

Note: The front roller can be put in three different positions depending on the application and needs of the user (Fig. 12).

- The front position is used when a groomer is installed.
- The middle position is used without a groomer.
- The third position can be used in extremely undulating turf conditions.

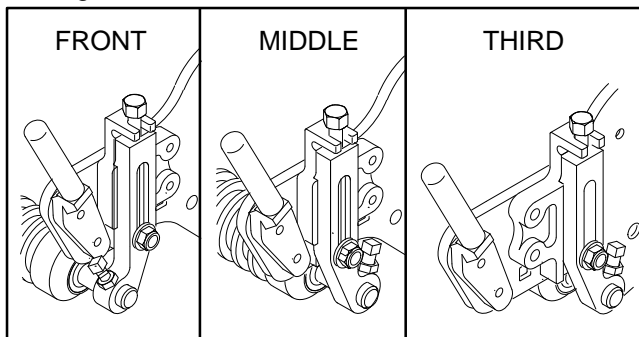

Figure 12

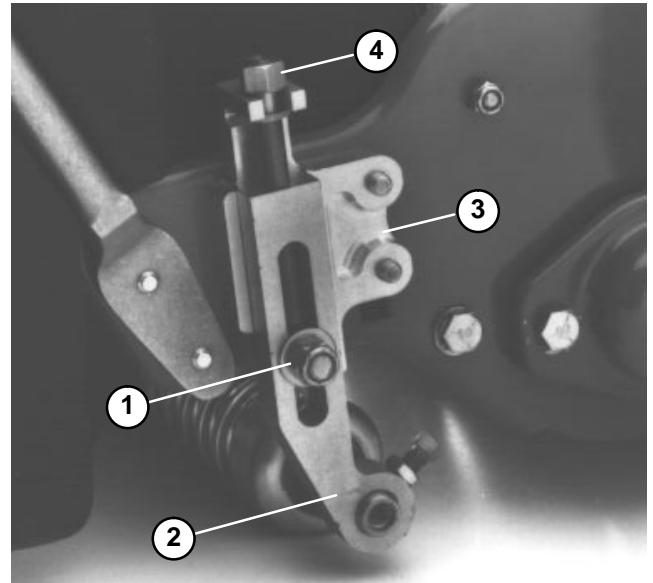

Figure 13

- | | |
|----------------------|--------------------------|
| 1. Lock nut | 3. Height-of-cut bracket |
| 2. Height-of-cut arm | 4. Height-of-cut screw |

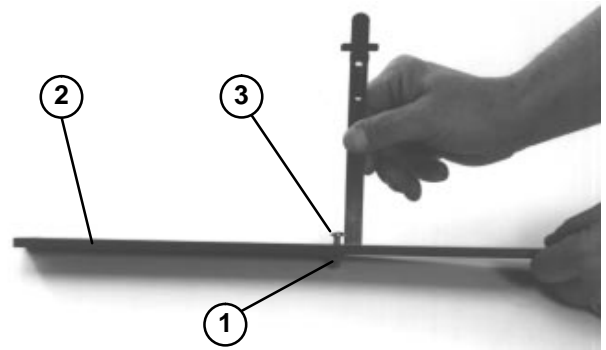

Figure 14

- | | |
|--------------|--------------------|
| 1. Nut | 3. Adjusting screw |
| 2. Gauge bar | |

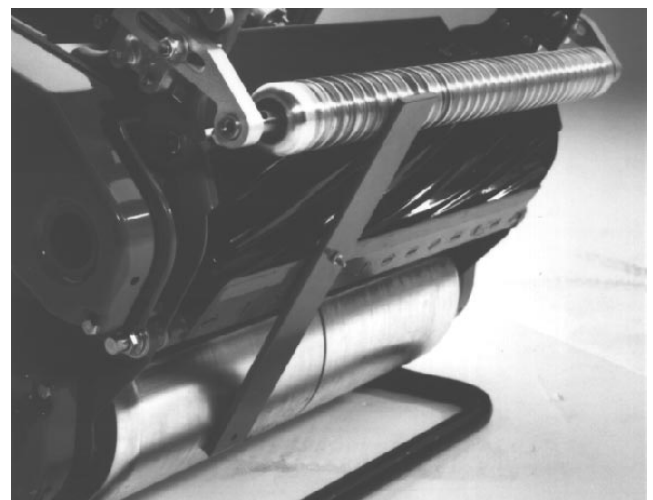

Figure 15

Grass Shield Height Adjustment

Adjust shield to assure proper grass clipping discharge into the basket.

1. Park mower on a level surface. Make sure engine is OFF. Remove high tension lead from the spark plug.
2. Measure distance from the top of the front support rod to the front lip of the shield at each end of cutting unit (Fig. 16).
3. The height from the support rod to the front lip of the shield for normal cutting conditions should be 4 inches.

Note: Shield can be lowered for drier conditions (clippings fly over top of basket) or raised to allow for heavy wet grass conditions (clippings build up on rear of basket).

4. Loosen capscrews and nuts securing each end of the shield to the side plates. Adjust shield to the correct height and tighten fasteners (Fig. 17).

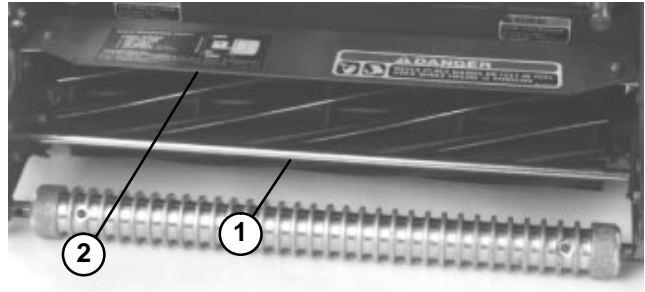

Figure 16

- | | |
|----------------|-----------|
| 1. Support rod | 2. Shield |
|----------------|-----------|

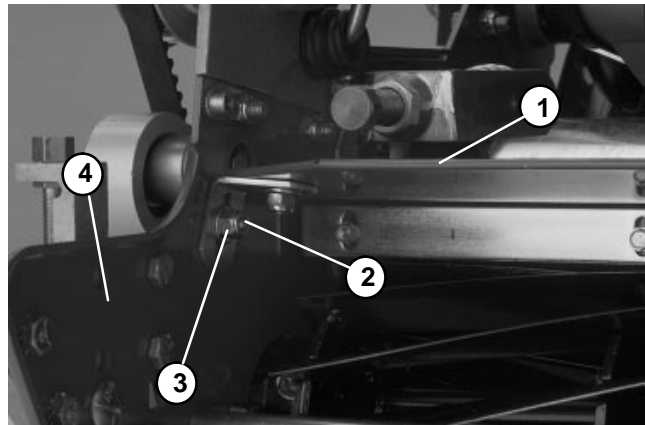

Figure 17

- | | |
|-----------------|---------------|
| 1. Grass shield | 3. Lock nut |
| 2. Cap screw | 4. Side plate |

Cutoff Bar Adjustment

Adjust cutoff bar to assure clippings are cleanly discharged from the reel area.

Note: The cutoff bar is adjustable to compensate for changes in turf conditions. The bar should be adjusted closer to the reel for extremely wet turf. However, adjust cutoff bar further away from the reel for dry turf. The bar should be parallel to the reel to assure optimum performance. Make sure cutoff bar is adjusted whenever the shield height is adjusted or the reel is sharpened.

1. Park mower on a level surface. Make sure engine is OFF. Remove high tension lead from the spark plug.
2. Loosen screws securing the cutoff bar. Insert a 0.060 inch (0.152 mm) feeler gauge between the top of the reel and the bar.
3. Tighten screws so that the distance between the cutoff bar and reel is equal for the complete length of the reel.

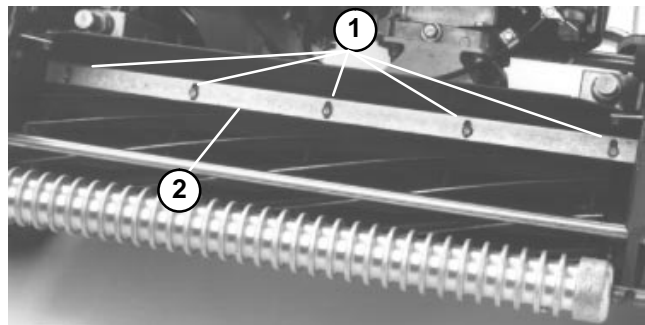

Figure 18

- | | |
|----------|---------------|
| 1. Screw | 2. Cutoff bar |
|----------|---------------|

Service and Repairs

Backlapping

1. Park mower on a level surface. Make sure engine is OFF. Remove high tension lead from the spark plug.
2. Make sure clutch to the reel drive is **DISENGAGED**.
3. Remove the cover plug in the right reel drive cover (Fig. 19).
4. Insert a 1/2-inch socket extension, which is connected to a backlapping machine, into the square hole in the center of the reel pulley.
5. Backlap according to procedure in TORO Sharpening Reel and Rotary Mowers Manual, Form No. 80-300 PT.

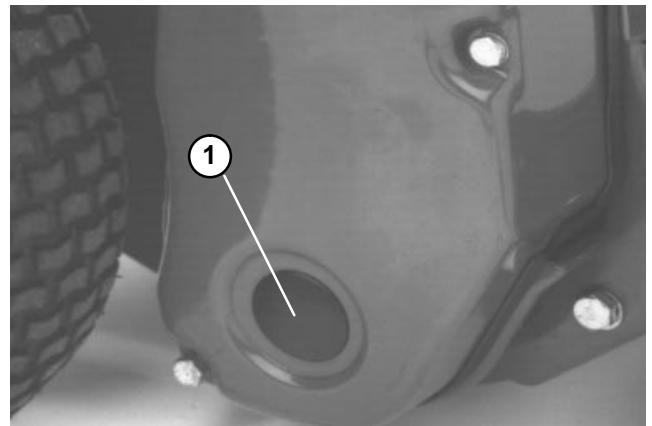

Figure 19

1. Cover plug

Lubrication

The grease fittings on the mower should be greased at least every 25 hours. **Grease immediately after washing regardless of the service interval listed.** Lubricate using No. 2 multipurpose lithium base grease. A hand operated grease gun is recommended for the best results.

1. Park mower on a level surface. Make sure engine is OFF. Remove high tension lead from the spark plug.
2. Wipe each grease fittings with a clean rag.

IMPORTANT: Do not apply too much pressure, or grease seals will become permanently damaged.

3. There are two fittings on the front roller and one on both reel bearing housings. Grease all fittings. Wipe off excess grease.

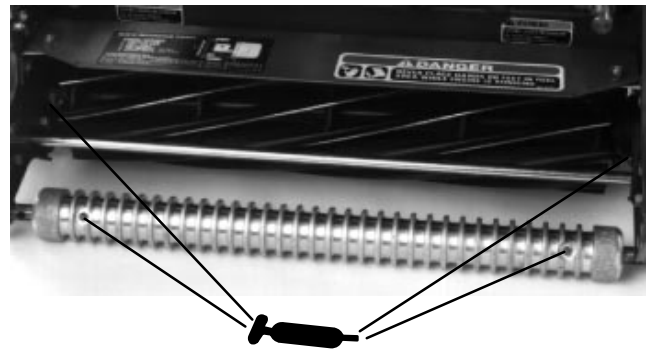

Figure 20

Bedbar

Removal

1. Position mower on a flat level work surface. Make sure engine is OFF. Remove high tension lead from the spark plug.
2. Loosen jam nut on the adjusting screw. Loosen adjusting screw until the thrust washer contacts the inside of the frame adjuster. Accomplish on both sides of the mower (Fig. 21).



WARNING

Use caution when removing the bedbar. Adjusting screw springs (Fig. 22) are under tension and could release suddenly.

3. Compress spring with a pair of channel lock pliers. Insert a pin to hold the spring in position (Fig. 22).
4. Loosen flange nuts on both sides of the mower. Remove both bedbar bolts on each side of the mower with the metal and nylon washers. Discard nylon washer (Fig. 23).
5. Remove bedbar from the mower. Keep metal washers and discard nylon washers. Remove and discard both nylon bushings (Fig. 24).

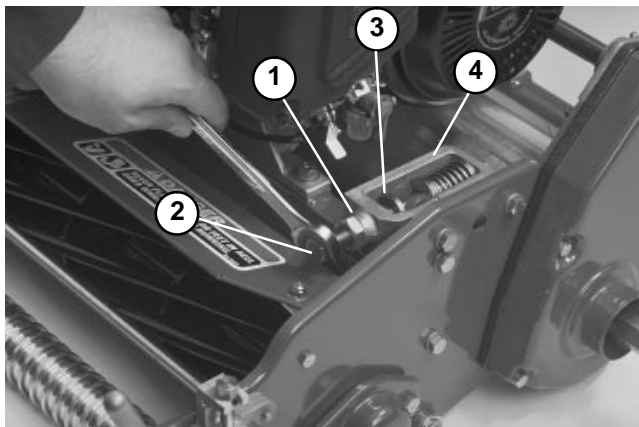

Figure 21

- | | |
|--------------------|-------------------|
| 1. Jam nut | 3. Thrust washer |
| 2. Adjusting screw | 4. Frame adjuster |

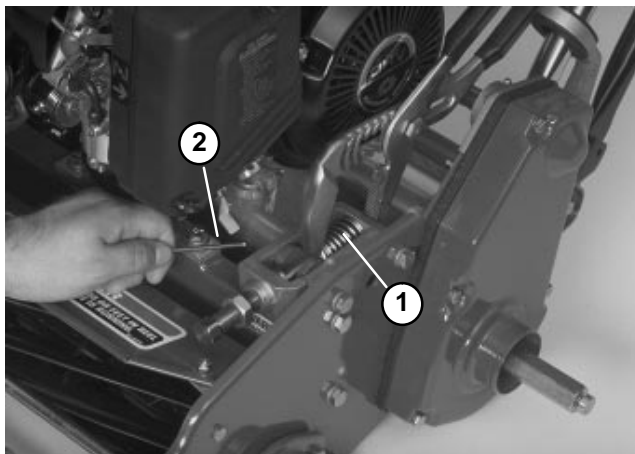

Figure 22

- | | |
|-----------|-----------------------|
| 1. Spring | 2. Pin (Allen wrench) |
|-----------|-----------------------|

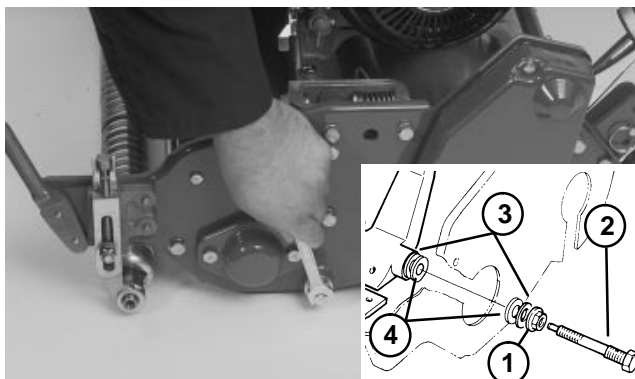

Figure 23

- | | |
|----------------|-----------------|
| 1. Flange nut | 3. Metal washer |
| 2. Bedbar bolt | 4. Nylon washer |

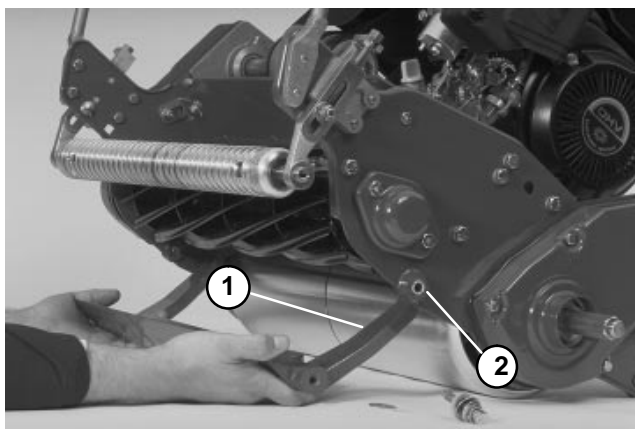

Figure 24

- | | |
|-----------|------------------|
| 1. Bedbar | 2. Nylon bushing |
|-----------|------------------|

Installation

Note: Use new nylon washers and bushings for installation.

1. Park mower on a level surface. Make sure engine is OFF. Remove high tension lead from the spark plug.
2. Use grease to hold thrust washers against the inside of both frame adjusters (Fig. 25).
3. Install new nylon bushings into both sides of the frame (Fig. 26).
4. Put anti-seize lubricant on the threads of bedbar bolts. Install nylon washer, metal washer, and bedbar bolt to both sides of the frame (Fig. 27).



WARNING

Use caution when removing the bedbar. Adjusting screw springs are under tension and could release suddenly (Fig. 28).

5. Compress spring with channel lock pliers. Remove pin from both frame adjusters. (Fig. 28).
6. Tighten and then torque both bedbar bolts from 240 to 320 in-lb (280 to 370 kg-cm). Tighten both flange nuts until metal washers can just rotate freely (Fig. 29).

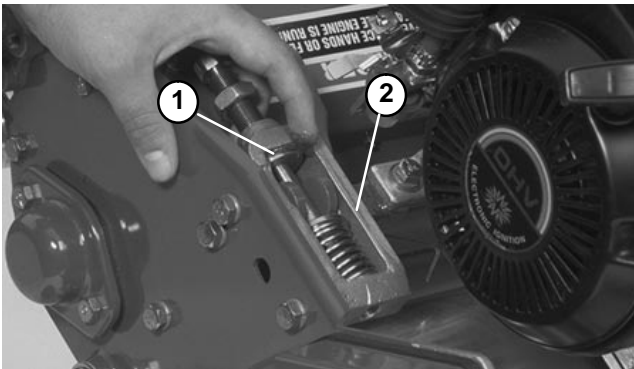

Figure 25

1. Thrust washer
2. Frame adjuster

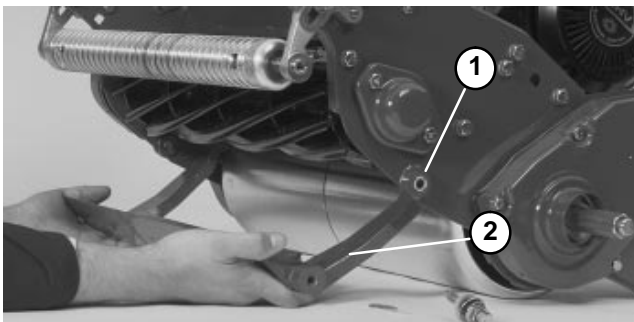

Figure 26

1. Nylon bushing
2. Bedbar

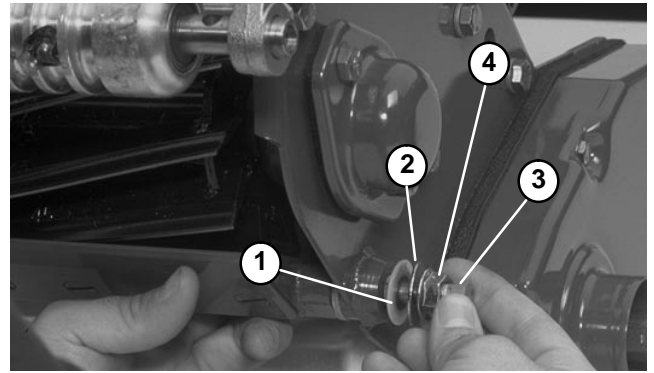

Figure 27

1. Nylon washer
2. Metal washer
3. Bedbar bolt
4. Flange nut

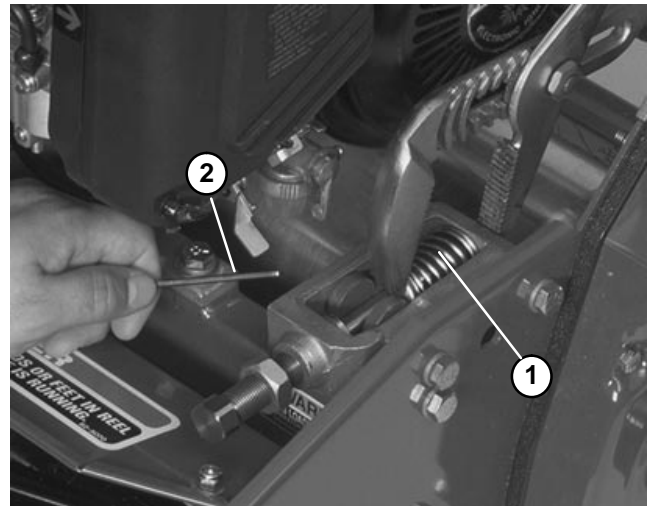
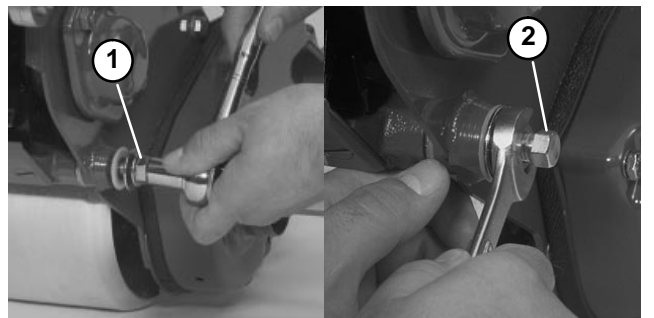

Figure 28

1. Spring
2. Pin (Allen wrench)



Torque to
240 to 320 in-lb
(280 to 370 kg-cm)

Figure 29

1. Flange nut
2. Bedbar bolt

Bedknife Replacement and Grinding

Removal

1. Remove bedbar from frame (see Bedbar Removal).
2. Remove screws from bedbar using a socket wrench and bedknife screw tool. Discard screws. Remove bedknife from the bedbar (Fig. 30).
3. Use a scraper to remove all rust, scale and corrosion from bedbar surface before installing new bedknife (Fig. 31).
4. Install bedbar to frame (see Bedbar Installation).

Replacement

1. Make sure bedbar threads are clean.
2. Use new screws. Apply anti-seize lubricant to the screw before installing.

IMPORTANT: Do not use an impact wrench to tighten screws into the bedbar.

3. Using a torque wrench and bedknife screw tool, tighten screws to a torque of 200 to 250 in-lb (230 to 288 kg-cm). Use a torquing pattern working from the center toward each end of the bedknife (Fig. 32).

Grinding

Since there can be variations in the mounting surface of the bedbar, a new bedknife will not be perfectly flat after it is installed. Because of this, it is necessary to backlap or grind a new bedknife after installing it to the bedbar. Follow the existing angle that was ground into the bedknife and grind only enough to make sure the top surface is true (Fig. 33).

1. Remove bedbar from the mower (see Bedbar Removal).

Note: When grinding, be careful to not overheat the bedknife. Remove small amounts of material with each pass of the grinder.

2. Use TORO Sharpening Reel and Rotary Mowers Manual, Form No. 80-300 PT, for grinding the bedknife.

Bedknife Grinding Specifications	
Relief Angle	5°
Relief Angle Range	3° to 6°
Front Angle	15°
Front Angle Range	13° to 17°

3. Reinstall bedbar to the mower (see Bedbar Installation).

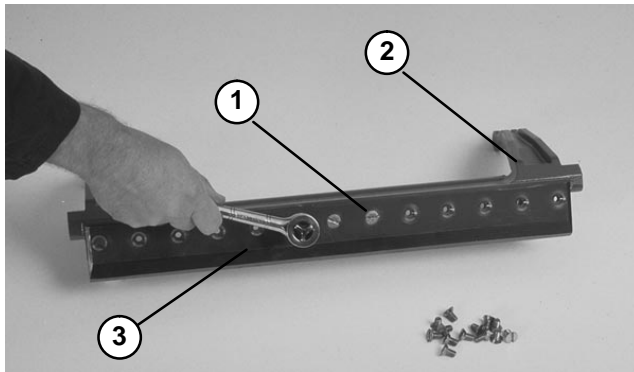

Figure 30

1. Screw
2. Bedbar
3. Bedknife



Figure 31

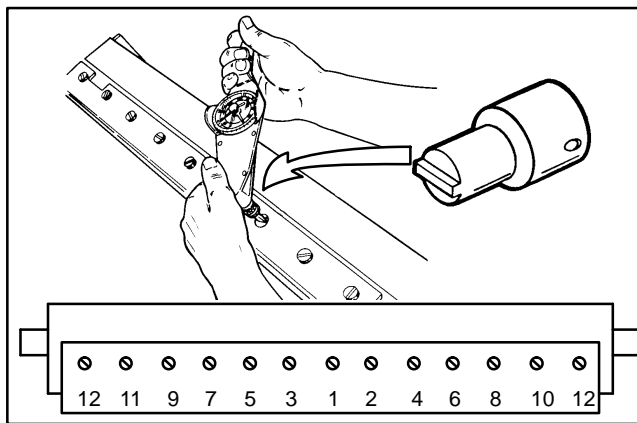

Figure 32

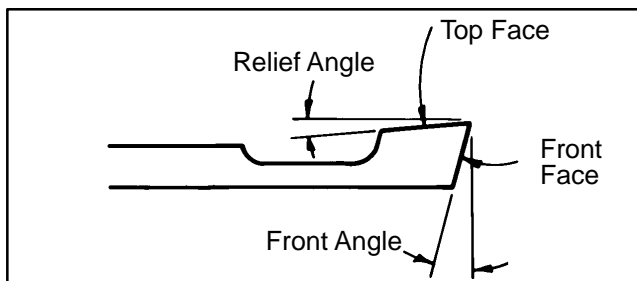

Figure 33

Roller

Removal

1. Park mower on a level surface. Make sure engine is OFF. Remove high tension lead from the spark plug.
2. Loosen jam nut and set screw on both ends of the mower.
3. On one end of the mower, remove lock nut and flat washer from the carriage screw.

Note: Do not adjust the height-of-cut screw when removing the height-of-cut arm.

4. Pull the height-of-cut arm from the roller shaft, carriage screw, and height-of-cut bracket. Remove the roller from the mower.

Installation

1. Place roller shaft into the height-of-cut arm that is still attached to the mower.
2. Place the removed height-of-cut arm onto the roller shaft. Secure height-of-cut arm into the height-of-cut bracket with with the carriage screw, flat washer, and lock nut.

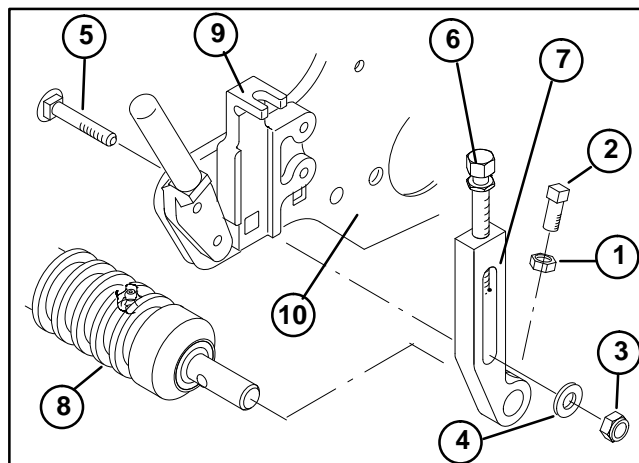

Figure 34

- | | |
|-------------------|--------------------------|
| 1. Jam nut | 6. Height-of-cut screw |
| 2. Set screw | 7. Height-of-cut arm |
| 3. Lock nut | 8. Roller |
| 4. Flat washer | 9. Height-of-cut bracket |
| 5. Carriage screw | 10. Frame |

3. Center roller evenly between both height-of-cut arms. Tighten roller shafts in place by tightening the set screw and then the jam nut.
4. Adjust roller for height-of-cut (see Height-of-Cut in the Adjustments section).

Roller Bearing Replacement

Note: A Wiehle roller is shown. Bearing configurations is the same for full, swaged, and wiehle rollers.

Remove Bearings

Note: Use the bearing replacement tool kit, described in the Special Tools section, to remove the roller bearings.

Note: It is recommended to replace bearings at both ends of the roller after bearing failure.

1. If a hole is not on the bearing shaft, use drill bushing to drill a hole in the bearing shaft.
2. Remove roller bearing with bearing puller.
3. Clean roller bearing cavity and remove any rust with crocus cloth.
4. Repeat above steps for the other roller bearing.

Install New Bearings

1. Make sure roller bearing cavity is clean and free of dirt. Apply No. 2 multipurpose lithium based grease to the roller bearing.

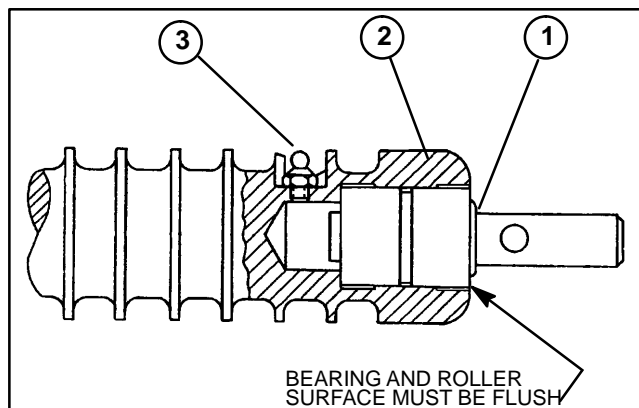

Figure 35

- | | |
|--------------------|-------------------|
| 1. Roller bearing | 3. Grease fitting |
| 2. Roller (Wiehle) | |

2. Press roller bearing into roller so that the outside surface of the bearing is flush with the end of the roller.
3. Grease the bearing with No. 2 multipurpose lithium based grease until grease appears at the seal of the bearing.
4. Repeat above steps for the other roller bearing.

Reel

Removal

1. Make sure engine is OFF. Remove high tension lead from the spark plug. Place mower on a flat level surface or on a stable work bench.
2. Remove bedbar from the mower (see Bedbar Removal).
3. If a grooming reel kit is installed, remove the cutting reel using the procedures in Frame Assemblies (RH and LH) and Cutting Reel in the Service and Repairs section of Chapter 8 – Grooming Reel Kit.
4. Remove four cap screws, four lock washers, and reel drive cover from the mower. Mark bearing housing (RH) for reassembly purposes (Fig. 36).
5. Remove reel drive belt from the pulley and drive assembly (see Service and Repair section of Chapter 4 – Traction and Reel Drive Systems).

IMPORTANT: Do not disassemble the pulley and drive assembly and retaining ring.

6. Use a 1/2-inch drive in the pulley and drive assembly (Fig. 36) to remove the assembly from the reel drive shaft. Also, remove bearing lock nut (Fig. 37) from the reel drive shaft at the same time.
7. Use an allen wrench and remove both flat head screws, groomer arm cover, and both cover standoffs from the bearing housing (Fig. 36).
8. Remove both cap screws, lock nuts, and bearing cover from the bearing housing (LH) (Fig. 37).
9. Remove grease fittings from both bearing housings (Fig. 36 and 37).
10. Pull both bearing housings from the frame and reel (Fig. 36 and 37). Remove the reel from the mower.

11. If bearings are worn or need replacement for maintenance purposes, remove bearings from **both** bearing housings as follows:

- A. Remove large seal, small seal, and bearing from the bearing housing (Fig. 37).
- B. Remove bearing seal, retaining ring, bearing, and wave washer from the bearing housing. Discard wave washer (Fig. 36).

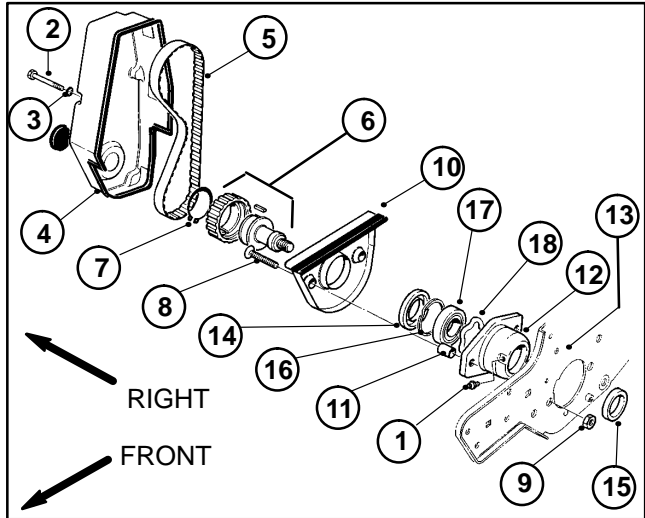

Figure 36

- | | |
|------------------------------|--------------------------|
| 1. Grease fitting | 10. Groomer arm cover |
| 2. Cap screw | 11. Cover standoff |
| 3. Lock washer | 12. Bearing housing (RH) |
| 4. Reel drive cover | 13. Frame |
| 5. Reel drive belt | 14. Large seal |
| 6. Pulley and drive assembly | 15. Small seal |
| 7. Retaining ring | 16. Retaining ring |
| 8. Flat head screw | 17. Bearing |
| 9. Nut | 18. Wave washer |

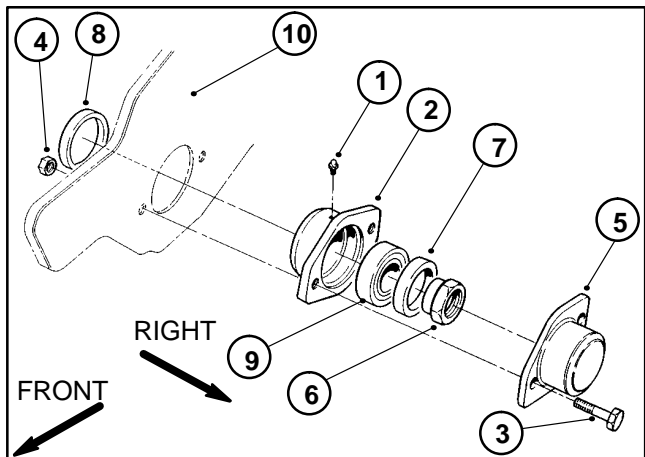

Figure 37

- | | |
|-------------------------|---------------------|
| 1. Grease fitting | 6. Bearing lock nut |
| 2. Bearing housing (LH) | 7. Large seal |
| 3. Cap screw | 8. Small seal |
| 4. Lock nut | 9. Bearing |
| 5. Bearing cover | 10. Frame |

Installation

1. Make sure engine is OFF. Remove high tension lead from the spark plug. Place mower on a flat level surface or on a stable work bench.

IMPORTANT: Make sure the correct bearing housing is used when installing bearings. The grease fitting hole should face forward when the housing is placed in the frame.

2. Reassemble bearing housing (LH) components (Fig. 37).

A. Place small seal into the bearing housing with the flat side out.

B. Press **new** bearing into the bearing housing with a bearing driver.

C. Place large seal on the bearing housing with the flat side out. Press seal in with a seal driver.

3. Reassemble bearing housing (RH) components (Fig. 36).

A. Bearing housing (RH) should be marked from disassembly.

B. Place small seal into the bearing housing with the flat side out.

C. Place **new** wave washer into housing. Press **new** bearing into the bearing housing with a bearing driver.

D. Install and seat retaining ring into the groove of the housing.

E. Place large seal on the bearing housing with the flat side out. Press seal in with a seal driver.

4. Position reel in frame to accept bearing housings. The reel shaft end with internal threads should be on the right side of the frame.

Note: The two bearing housings are similar in appearance but can not be interchanged. The bearing housing (RH) was marked during disassembly.

5. Attach bearing housing (RH) through the frame onto the reel shaft (Fig. 36).

A. Push housing onto reel shaft. If necessary, tap into position with a soft hammer.

B. Make sure grease fitting hole is position to the front of the mower.

C. Attach the groomer arm cover to the bearing housing and frame with the two flat head screws, cover standoffs, and lock nuts. Do not tighten down fasteners.

6. Attach bearing housing (LH) through the frame onto the reel shaft (Fig. 37).

A. Push housing onto reel shaft. If necessary, tap into position with a soft hammer.

B. Make sure grease fitting hole is position to the front of the mower.

C. Align housing holes to frame holes with both cap screws and lock nuts. Fasteners should be only finger tight.

7. While tightening the bearing lock nut (Fig. 37) to the reel shaft, tighten pulley and drive assembly (Fig. 36) to the reel shaft at the same time. Torque assembly and nut to 50 ft–lb (6.9 kg–m).

8. Tighten flat head screws and nuts securing the bearing housing (RH) to the frame (Fig. 36).

9. Remove both cap screws and lock nuts holding the bearing housing (LH) to the frame. Position bearing cover to housing and secure to frame with both cap screws and lock nuts (Fig. 37).

10. Reinstall reel drive belt to the pulley and drive assembly (see Service and Repair section of Chapter 4 Traction and Reel Drive Systems).

11. Reinstall reel drive cover with four lock washers and cap screws to the mower. Tighten cap screws (Fig. 36).

12. Reinstall grease fittings to both bearing housings. Lubricate both housings with No. 2 multipurpose lithium base grease (Fig. 37 and 36).

13. Reinstall bedbar to the mower (see Bedbar Removal).

14. Complete mower set-up and adjustment sequence (see Adjustments section).

Preparing a Reel for Grinding

Note: Check to make sure the reel bearings are in good condition and properly adjusted before grinding a reel.

1. Remove bedbar assembly (see Bedbar Removal).
2. Raise grooming reel, if installed, by rotating both quick-up levers so they face the rear of the mower.

Note: Some older grinding machines may require that the cutting reel be removed.

3. Remove roller and both height-of-cut arms (see Roller Removal).

Note: The cutting unit must be aligned so the grinding wheel will travel parallel to the reel shaft. This will result in the the reel being ground to the desired cylinder shape.

Note: When grinding, be careful to not overheat the reel blades. Remove small amounts of material with each pass of the grinder.

4. After completing grinding process:

- A. Install height-of-cut arms and roller (see Roller Installation).
- B. Install bedbar assembly (see Bedbar Installation).
- C. Complete mower set-up and adjustment sequence (see Adjustments section).

Reel Grinding Specifications	
Nominal Reel Diameter	5 in (126 mm)
Service Limit Reel Diameter	4.5 in (114 mm)
Blade Relief Angle	30°
Relief Angle Range	20° to 40°
Blade Land Width	0.040 in (1.0 mm)
Land Width Range	0.030 to 0.060 in (0.7 to 1.5 mm)
Max. Reel Taper	0.040 in (1.0 mm)

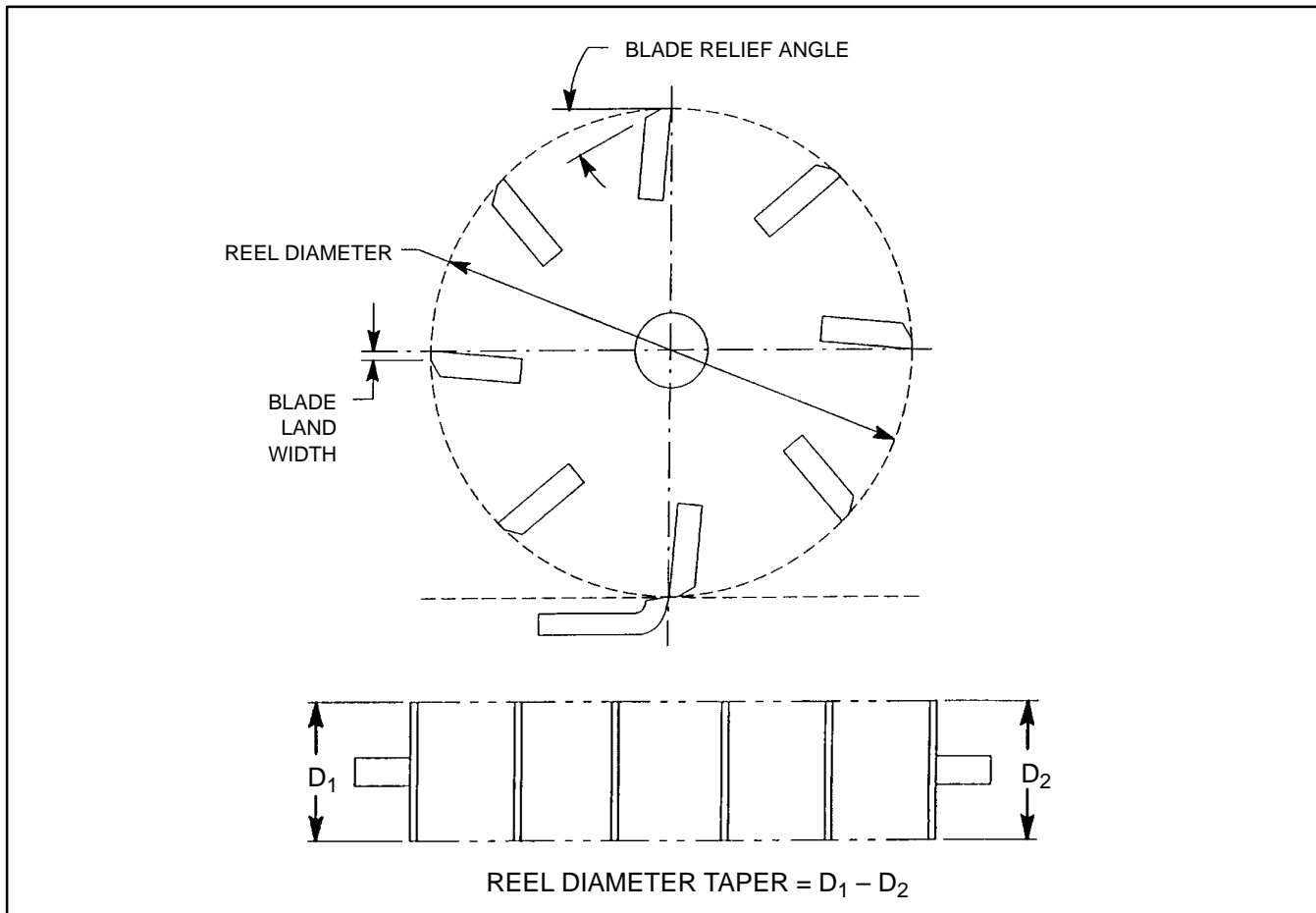

Figure 38



Grooming Reel Kit

Table of Contents

SPECIFICATIONS	2	SERVICE AND REPAIRS	8
GENERAL INFORMATION	3	Reel	8
Clutch Engagement/Disengagement	3	Reel Bearing Replacement	11
TROUBLESHOOTING	4	Drive Belt Replacement	11
Factors Affecting Grooming	4	Clutch Assembly	12
Grooming Reel Mechanical Problems	5	Frame Assemblies (RH and LH)	14
ADJUSTMENTS	6	Cutting Reel	20
Height/Depth of Grooming Adjustment	6	Lubrication	21
Drive Belt Tension Adjustment	7		

Note: This chapter covers the grooming reel kit (Model No. 04125), which is used only on the Greensmaster 1000.

Specifications

MOUNTING: The grooming kit is rigidly mounted to the mower reel bearing housings and frame.

REEL CONSTRUCTION: 2-1/4 inch (5.4 cm) diameter, 41 steel blades with 1/2-inch blade spacing. Spacing is also adjustable at 1/4 and 3/4-inch (6.4 and 19.1 mm) by varying the number of blades and spacers.

GROOMING PENETRATION: Maximum of 0.18 inch (4.6 mm)

MICRO ADJUSTMENT KNOB: Allows a 0.007 inch (0.18 mm) increment of height adjustment

QUICK UP-DOWN FEATURE: Allows grooming reel to be raised 5/16 inch (7.9 mm) above the height/depth adjustment for no grooming reel action while cutting.

WIDTH-OF-GROOMING: 19 inches (48.3 cm)

OPTIONAL EQUIPMENT:
Groomer Brush Assembly Part No. 65-8330

General Information

Clutch Engagement/Disengagement

The grooming reel should be disengaged at all times except during grooming.

IMPORTANT: When engaging or disengaging the clutch, be sure to turn the clutch knob all the way until it comes to a firm stop. Failure to do so could cause damage to the clutch.

1. Depress clutch snubber and engage the clutch by turning the clutch knob counterclockwise.
2. Turn clutch knob clockwise to disengage the clutch.

Transport Mode

IMPORTANT: When transporting the mower, make sure groomer clutch is disengaged and the grooming reel is raised to its transport position.

1. To raise the grooming reel, rotate both quick-up levers so they face to the rear of the mower.
2. To lower the grooming reel, rotate both quick-up levers so they face to the front of the mower, then engage the clutch.

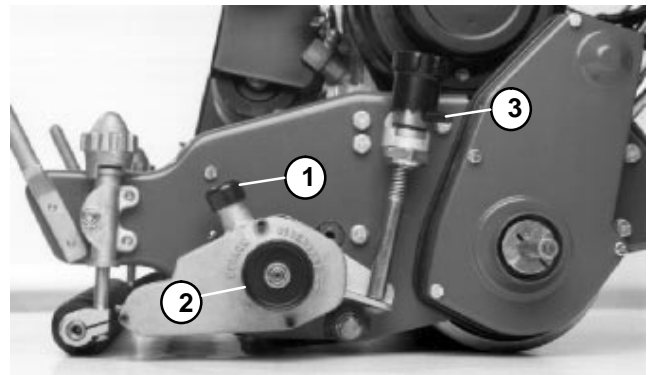

Figure 1

1. Clutch snubber
2. Clutch knob
3. Quick-up lever

Troubleshooting

Factors Affecting Grooming

There are a number of factors that can affect the performance of grooming. These factors vary for different golf courses and from green to green. It is important to inspect the turf frequently and vary the grooming practice with turf needs.

It is important to remember that factors affecting quality of cut also affect grooming performance.

IMPORTANT: Improper or overaggressive use of the grooming reel, such as too deep or frequent grooming, may cause unnecessary stress on the turf leading to severe turf damage. Use the groomer carefully. READ AND UNDERSTAND THE OPERATOR'S BEFORE OPERATING OR TESTING GROOMER PERFORMANCE.

Variables That Affect the Use and Performance of Grooming Reels

1. The Growing season and weather conditions
2. General turf conditions
3. The frequency of grooming/cutting – number of cuttings per week and how many passes per cutting
4. The blade spacing on the grooming reel
5. The height of cut
6. The grooming depth
7. The amount of time that a grooming reel has been in use on a particular turf area
8. The type of grass on the green
9. The overall turf management program – irrigation, fertilizing, weed control, coring, overseeding, sand dressing, and disease and pest control
10. The amount of traffic on the turf
11. Stress periods for turf – high temperatures, high humidity, unusually high traffic

Grooming Reel Mechanical Problems

Problem	Possible Causes	Correction
The grooming reel rotates when it is in the raised position with the clutch disengaged.	<p>Due to friction in the clutch assembly, the grooming reel may still rotate (with minimal force) in the raised position with the clutch disengaged.</p> <p>The clutch is not fully disengaged.</p> <p>The clutch pulley bearing may be seized.</p> <p>The clutch may be damaged or assembled incorrectly.</p>	<p>This condition may change over a period of time. Disassemble and clean clutch assembly.</p> <p>Make sure clutch knob set screws are tight against the flats on the release disk, and they do not allow the knob to slip.</p> <p>Replace pulley bearing.</p> <p>Repair or replace clutch if necessary.</p>
The clutch is engaged but does not provide power to the grooming reel.	<p>The clutch is not fully engaged.</p> <p>The clutch is damaged or assembled incorrectly.</p> <p>The belt is out of adjustment.</p> <p>The belt broken or damaged.</p>	<p>Make sure clutch knob set screws are tight against the flats on the release disk and do not allow clutch knob to slip. IMPORTANT. When engaging or disengaging the clutch, be sure to push the snubber down and turn the knob all the way until it comes to a firm stop.</p> <p>Repair or replace clutch if necessary.</p> <p>If the belt slips, it probably is damaged and must be replaced.</p> <p>Repair or replace belt if necessary. A broken or worn belt could be the result of improper belt adjustment or seized grooming reel bearings.</p>
The turf is damaged or has uneven grooming.	<p>The grooming reel blades are bent, damaged, or missing.</p> <p>The grooming reel shaft is bent or damaged.</p> <p>Grooming depth is not equal on both ends of groomer reel.</p>	<p>Replace blades if necessary.</p> <p>Replace grooming reel shaft.</p> <p>Adjust depth if necessary. Check and adjust cutting unit set up (level bedknife to reel, level rear roller to reel, set height of cut, etc.)</p>
The groomer reel does not raise completely to the transport position. Quick-up levers have free play or do not rotate completely to the rear.	Groomer reel interfering with cutting unit frame side plate.	Check side plate for proper cut-out and modify if necessary.

Adjustments



CAUTION

Never work on the mower with the engine running. Always stop the engine and remove the high tension lead from the spark plug first.

Height/Depth of Grooming Adjustment

1. Park mower on a level surface. Make sure engine is OFF. Remove high tension lead from the spark plug.
2. Make sure rollers are clean and cutting reel is set to the desired height of cut (see Adjustments section of Chapter 7 – Cutting Unit). Position mower on a flat level working surface.
3. Hold clutch snubber down and disengage the clutch by turning the clutch knob clockwise. Use quick-up levers on both sides of the mower to lower the grooming reel into the grooming position (Fig. 2).
4. .On one end of the grooming reel, measure the distance from the lowest tip of the groomer blade to the working surface (Fig. 3). Lift and turn micro adjustment knob to raise or lower the tip (Fig. 2). Each notch on the micro adjustment knob is approximately equal to 0.007 inch (0.178 mm).
5. Repeat step 3 above on the opposite end of the groomer. Then, recheck setting on the first side of groomer.
6. Raise grooming reel to the transport position.

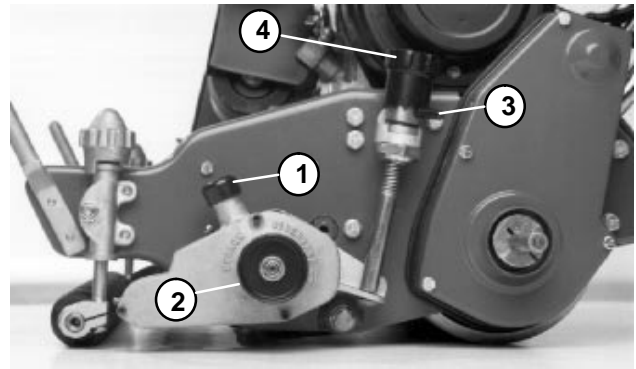

Figure 2

- | | |
|-------------------|--------------------------|
| 1. Clutch snubber | 3. Quick-up lever |
| 2. Clutch knob | 4. Micro adjustment knob |

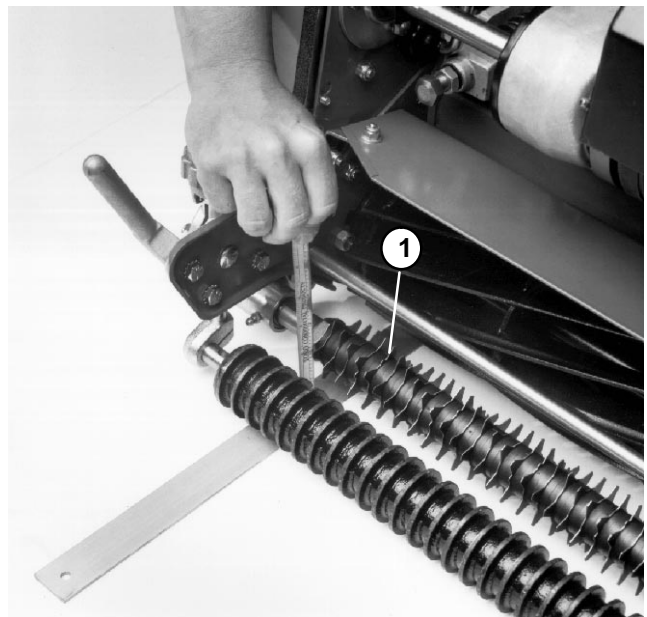

Figure 3

1. Grooming reel

Drive Belt Tension Adjustment

1. Park mower on a level surface. Make sure engine is OFF. Remove high tension lead from the spark plug.

2. Loosen both set screws in the clutch knob. Remove clutch knob and poly washer from the clutch assembly.

3. Remove three socket head cap screws and lock washers, then remove belt cover.

4. Check drive belt tension as follows:

A. Apply 5 to 10 lb (22 to 44 N) of force on the drive belt midway between the driver pulley and driven pulley.

B. Drive belt deflection should be about 0.25 inch (6.4 mm).

C. If belt tension is not acceptable, loosen the socket head cap screw on the idler block.

D. Pivot idler to get proper tension on the drive belt. Tighten the socket head cap screw.

E. Verify drive belt tension and readjust it as necessary. Torque the socket head cap screw from 7 to 10 ft-lb (1.0 to 1.4 kg-m).

5. Secure belt cover to housing with three socket head cap screws and lock washers.

6. Reinstall poly washer and clutch knob to the clutch assembly. Tighten both set screws in the clutch knob.

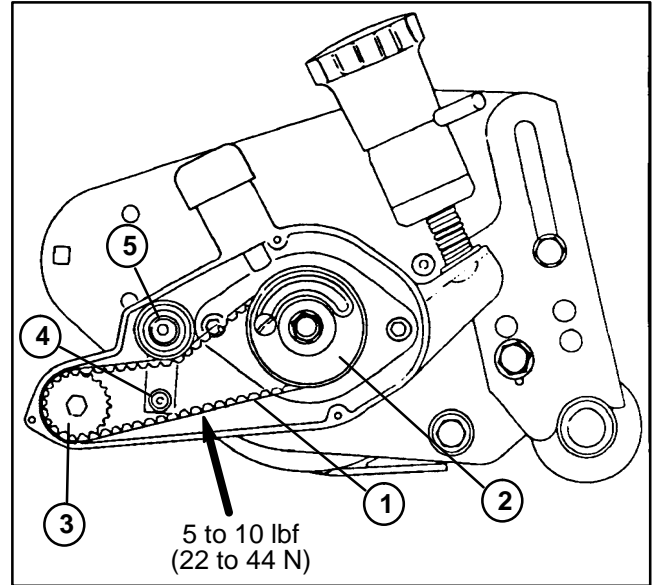

Figure 4

- | | |
|------------------|--------------------------|
| 1. Drive belt | 4. Socket head cap screw |
| 2. Driver pulley | 5. Idler pulley |
| 3. Driven pulley | |

Service and Repairs

Reel

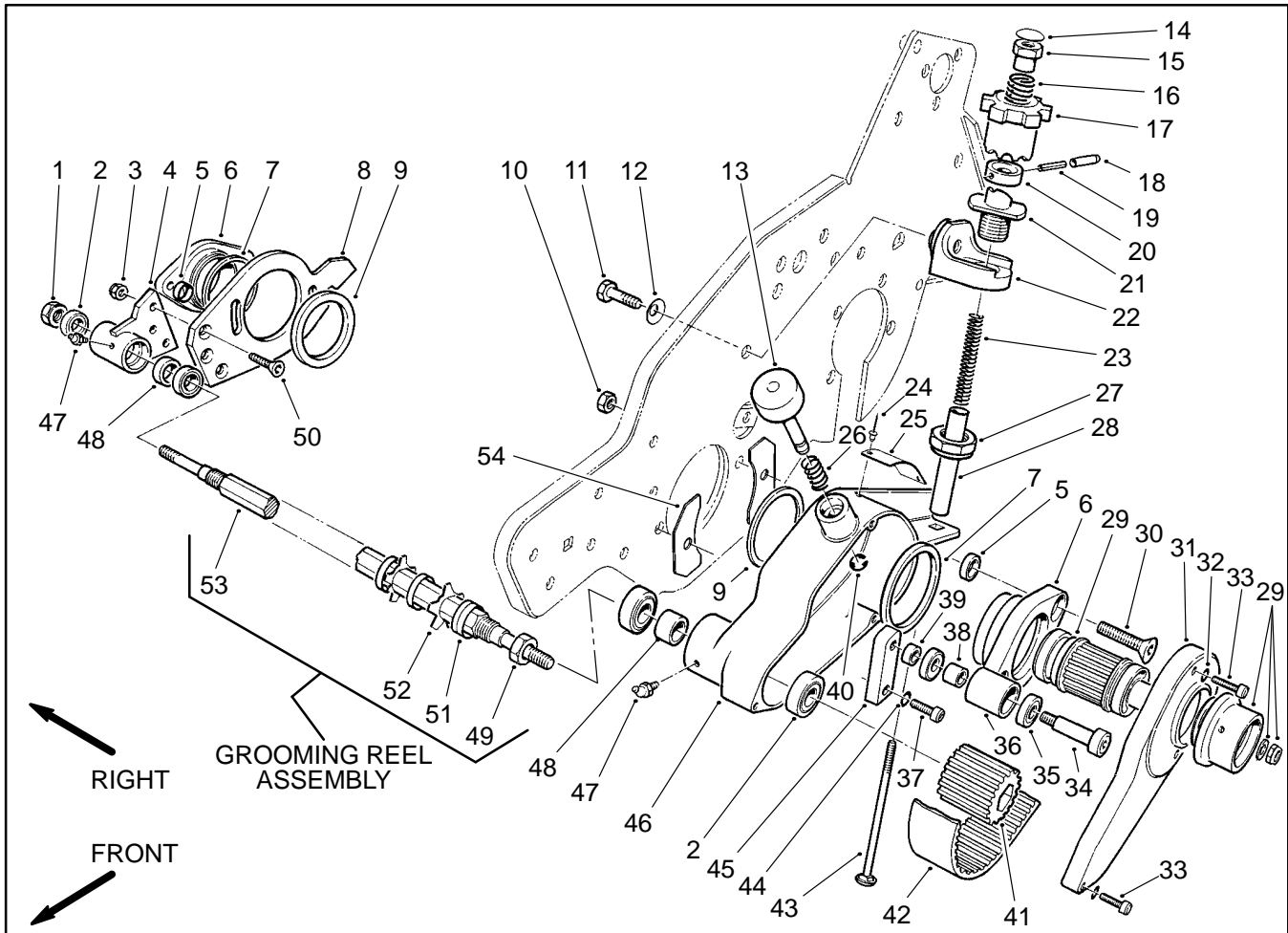

Figure 5

- | | | |
|-----------------------|----------------------------|----------------------------|
| 1. Lock nut | 19. Roll pin | 37. Socket head cap screw |
| 2. Ball bearing | 20. Cap | 38. Idler pulley spacer |
| 3. Lock nut | 21. Ramp | 39. Spacer |
| 4. Bearing housing | 22. Mounting block | 40. Retaining ring |
| 5. Spacer | 23. Spring | 41. Driven pulley |
| 6. Adapter | 24. Pop rivet | 42. Drive belt |
| 7. Bearing | 25. Caution plate | 43. Carriage bolt |
| 8. Side plate | 26. Spring | 44. Lock washer |
| 9. Adapter ring | 27. Lock nut | 45. Idler block |
| 10. Lock nut | 28. Spring spacer | 46. Belt drive housing |
| 11. Cap screw | 29. Clutch assembly | 47. Grease fitting |
| 12. Belleville washer | 30. Flat head socket screw | 48. Driven pulley spacer |
| 13. Cap | 31. Belt cover | 49. Lock nut |
| 14. Plug | 32. Lock washer | 50. Flat head socket screw |
| 15. Driver | 33. Socket head cap screw | 51. Spacer |
| 16. Spring | 34. Shoulder screw | 52. Blade |
| 17. Adjustment knob | 35. Bearing | 53. Shaft |
| 18. Pin cover | 36. Idler pulley | 54. Slot cover |

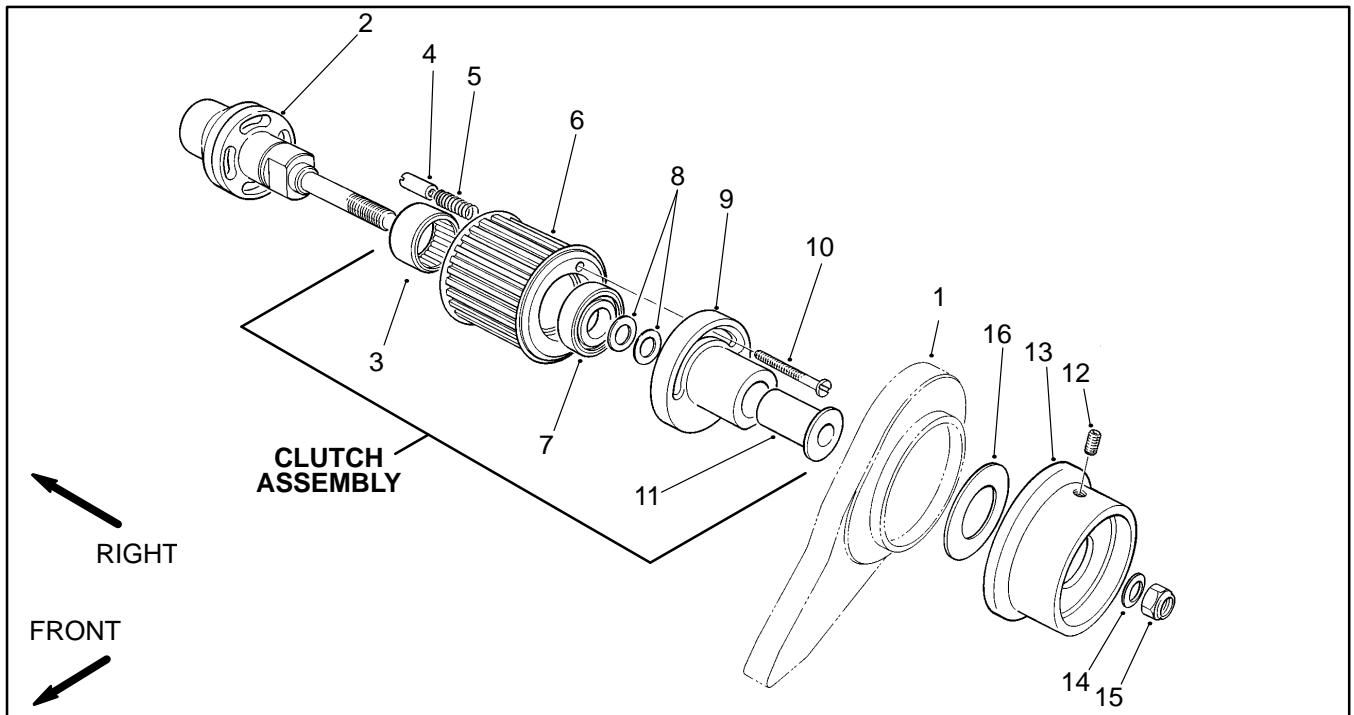

Figure 6

- | | | |
|-------------------------|------------------------|-----------------|
| 1. Belt cover | 7. Roller bearing | 12. Set screw |
| 2. Clutch drive adapter | 8. Belleville washer | 13. Clutch knob |
| 3. Needle bearing | 9. Clutch release disc | 14. Flat washer |
| 4. Clutch pin | 10. Special screw | 15. Lock nut |
| 5. Compression spring | 11. Flange bushing | 16. Poly washer |
| 6. Driver pulley | | |

The grooming reel can be removed to reverse the shaft, replace individual blades, or replace the entire shaft. The shaft is reversed so that the sharpest edge of the blades are forward.

Removal

1. Park mower on a level surface. Make sure engine is OFF. Remove high tension lead from the spark plug.
2. Loosen both set screws in the clutch knob. Remove clutch knob and poly washer from the clutch assembly (Fig. 6).
3. Remove three socket head cap screws and washers, then remove belt cover (Fig. 7).
4. In the belt drive housing (46), disassemble the following parts (Fig. 5):

A. Loosen socket head cap screw (37). Pivot idler pulley (36) away from the drive belt (42). Remove drive belt from the driven pulley (41).

Note: The driven pulley (41) has **left handed** threads.

B. Use an allen wrench to remove driven pulley from the shaft (53).

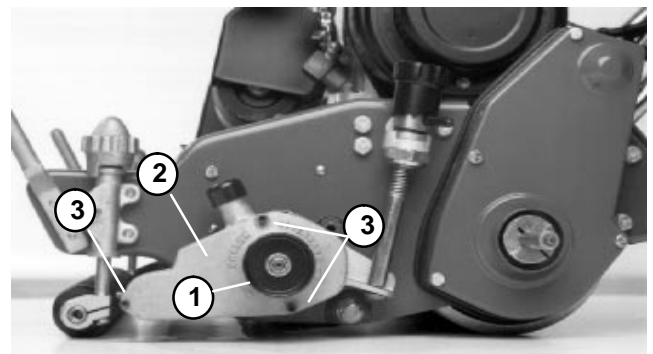

Figure 7

1. Clutch knob
2. Belt cover
3. Socket head cap screw and washer

5. From the right side of the mower, remove the following (Fig. 5):

A. Remove lock nut (1) that secures the shaft (53) to the bearing housing (4).

B. Remove three flat head socket screws (50) and lock nuts (3), then remove bearing housing from the side plate (8) and shaft.

C. Pull grooming reel assembly from the belt drive housing (46).

Disassembly

Inspect grooming reel blades frequently for damage and wear. Straighten bent blades with a pliers. Either replace worn blades or reverse the grooming reel shaft to put the sharpest blade edge forward (Fig. 8).

1. Remove one lock nut from either end of the shaft (Fig. 9).
2. Remove spacers and blades as necessary.

Reassembly

1. Start placing two spacers against the lock nut. Then, place blade against spacers (Fig. 9).
2. Rotate location mark on each blade one flat of the shaft, either in a clockwise or counterclockwise direction. The direction of rotation must remain constant on the shaft (Fig. 8).
3. Make sure there are two spacers between each blade. Blades and spacers should be centered on the shaft (Fig. 9).
4. Screw lock nut on the shaft and torque both lock nuts from 200 to 250 ft-lb (27.7 to 34.6 kg-m) so spacers are **not** free to rotate.

Installation

Note: The driven pulley (42) has **left handed** threads.

1. Park mower on a level surface. Make sure engine is OFF. Remove high tension lead from the spark plug.
2. Place grooming reel shaft (53) into the belt drive housing (46). Screw driven pulley (41) on the shaft. **Do not tighten** (Fig. 5).
3. From the right side of the mower, install the following (Fig. 5):
 - A. Install bearing housing (4) onto the other end of the shaft (53) and side plate (8).
 - B. Secure the bearing housing to the side plate with three flat head socket screws (50) and lock nuts (3).
 - C. Secure lock nut (1) to the shaft.
4. While holding the lock nut (1), tighten driven pulley (42) to the shaft (53) (Fig. 5).
5. Reinstall drive belt onto the driven pulley. Adjust drive belt tension (see Drive Belt Tension in Adjustments section) and torque socket head cap screw from 7 to 10 ft-lb (1.0 to 1.4 kg-m) (Fig. 10).

6. Secure belt cover to housing with three socket head cap screws and washers (Fig. 7). Reinstall poly washer and clutch knob to clutch assembly. Tighten both set screws into the clutch knob (Fig. 6).

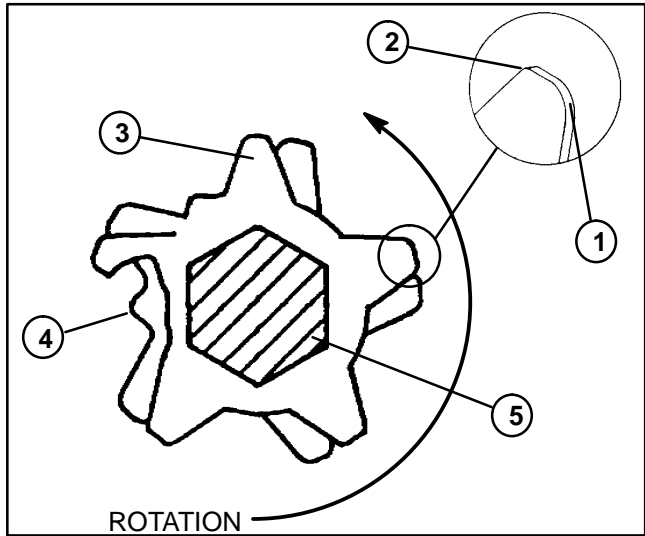

Figure 8

- | | |
|-----------------------|------------------|
| 1. Dull rounded edge | 4. Location mark |
| 2. Sharp pointed edge | 5. Shaft |
| 3. Grooming blade | |

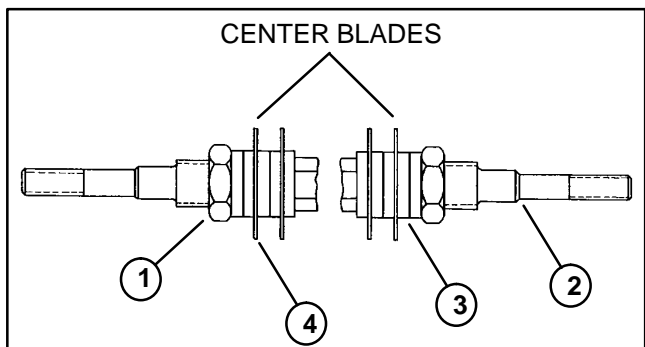

Figure 9

- | | |
|-------------|-----------|
| 1. Lock nut | 3. Spacer |
| 2. Shaft | 4. Blade |

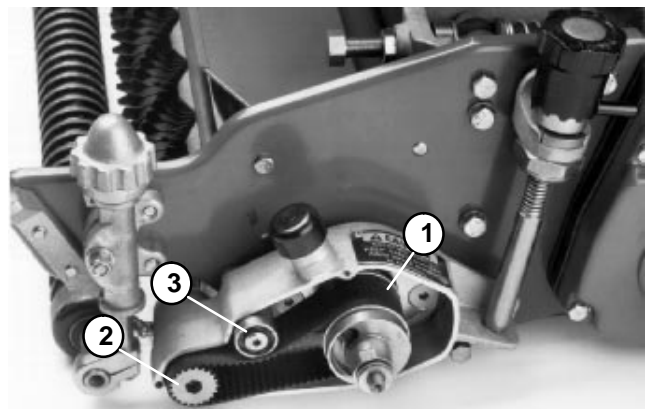

Figure 10

- | | |
|------------------|--------------------------|
| 1. Drive belt | 3. Socket head cap screw |
| 2. Driven pulley | |

Reel Bearing Replacement

1. Remove grooming reel (see Reel Removal).

Note: Replace all four ball bearings as a complete set.

2. Check condition of groomer ball bearings and replace as necessary.

A. In the bearing housing and belt drive housing, install outer ball bearing first with the seal facing out.

B. Install both driven pulley spacers into each housing.

C. Install inner bearing in both housings so they are flush with the housing inner recess of the housing (Fig. 11).

3. Install grooming reel (see Reel Installation).

4. Lubricate bearings with No. 2 multipurpose lithium base grease.

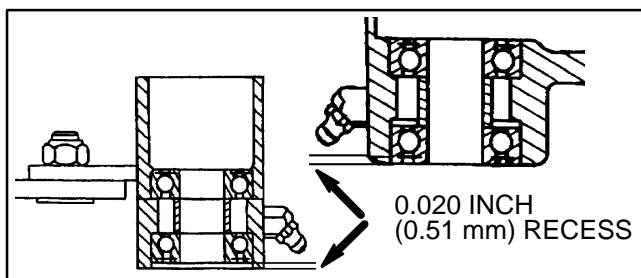

Figure 11

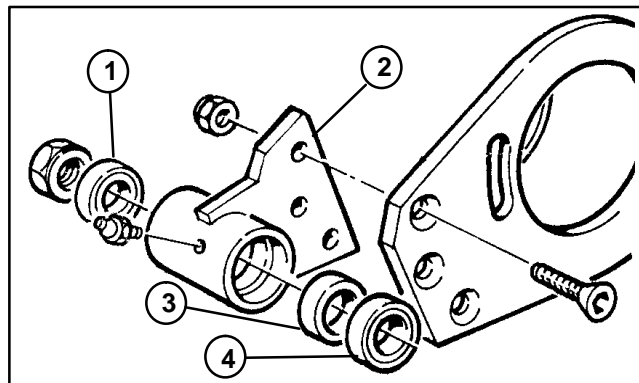

Figure 12

- | | |
|-----------------------|-------------------------|
| 1. Outer ball bearing | 3. Driven pulley spacer |
| 2. Bearing housing | 4. Inner ball bearing |

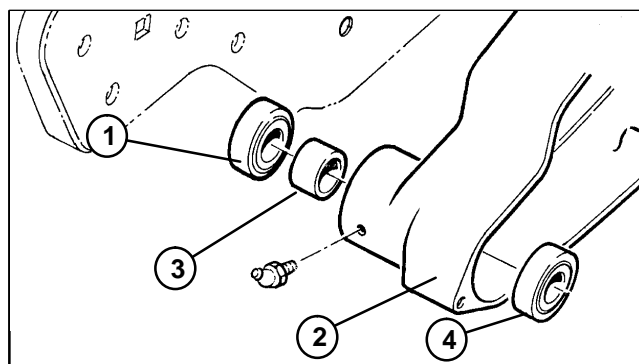

Figure 13

- | | |
|-----------------------|-------------------------|
| 1. Outer ball bearing | 3. Driven pulley spacer |
| 2. Bearing housing | 4. Inner ball bearing |

Drive Belt Replacement

1. Park mower on a level surface. Make sure engine is OFF. Remove high tension lead from the spark plug.

2. Loosen both set screws in the clutch knob. Remove clutch knob and poly washer from the clutch assembly (Fig. 6).

3. Remove three socket head cap screws and washers, then remove belt cover (Fig. 7).

4. Loosen socket head cap screw on the idler block. Pivot idler to loosen drive belt and remove belt (Fig. 14).

5. Install new drive belt. Tension drive belt and tighten socket head cap screw (see Drive Belt Tension Adjustment).

6. Secure belt cover to housing with three socket head cap screws and lock washers (Fig. 7).

7. Reinstall poly washer and clutch knob to the clutch assembly. Tighten set screws in the clutch knob (Fig. 6).

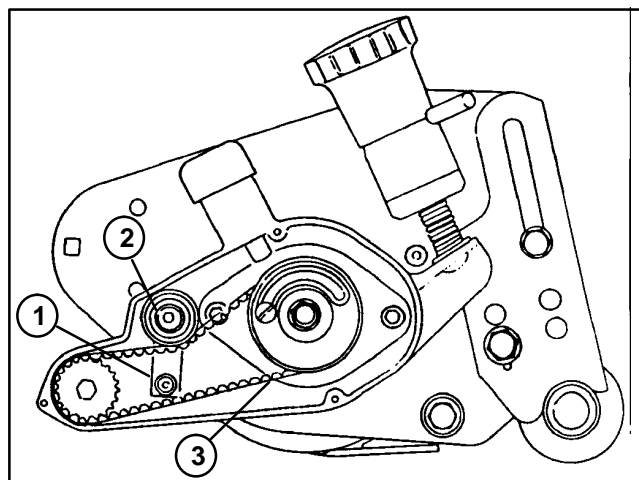

Figure 14

- | | |
|--------------------------|---------------|
| 1. Socket head cap screw | 3. Drive belt |
| 2. Idler | |

Clutch Assembly



CAUTION

Do not use your hand to prevent the cutting reel from turning while servicing; this can result in personal injury. Insert a block of hard wood into the front of the cutting unit between the reel blades to prevent the reel from turning.

Removal

1. Park mower on a level surface. Make sure engine is OFF. Remove high tension lead from the spark plug.
2. Loosen set screws in the clutch knob. Remove clutch knob and poly washer from the clutch assembly (Fig. 6).
3. Remove three socket head cap screws and washers, then remove belt cover (Fig. 7).
4. Loosen socket head cap screw on idler block. Pivot idler to loosen drive belt and remove belt (Fig. 14).
5. Remove lock nut and flat washer from the shaft of the clutch drive adapter. Pull clutch assembly off the shaft of the clutch drive adapter (Fig. 6).
6. Remove clutch adapter from the reel shaft if necessary (Fig. 15).

Disassembly (Fig. 6)

Note: The special screw and clutch pin were assembled with Loctite 271. It might be necessary to apply heat to these parts prior to disassembly.

1. Remove special screw, clutch pin, and compression spring from the driver pulley.
2. Separate flange bushing, clutch release disc, and both belleville washers from the driver pulley.
3. Inspect needle and roller bearings for damage. Replace bearings if worn or damaged.

Reassembly (Fig. 6)

1. Pack needle and roller bearings and the inside of the driver pulley with No. 2 multipurpose lithium based grease. Press both bearings into the driver pulley with seal side out.

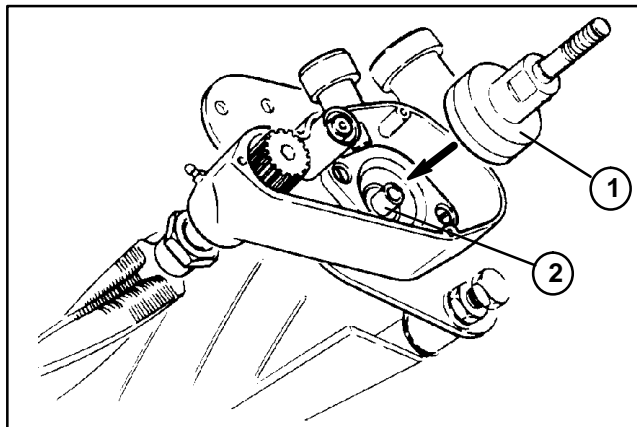

Figure 15

1. Clutch drive adapter 2. Reel shaft

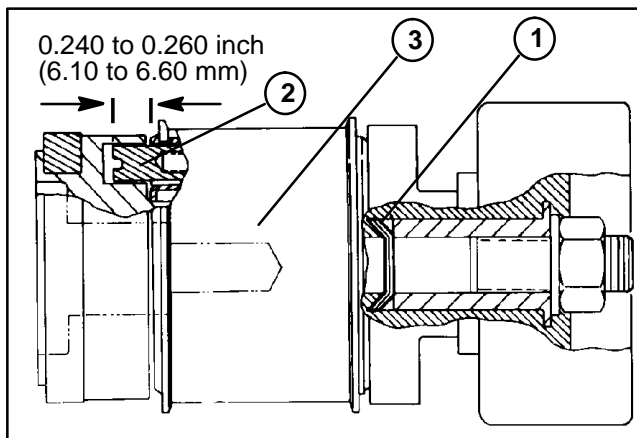

Figure 16

1. Belleville washers 3. Driver pulley
2. Clutch pin

IMPORTANT: Keep grease off special screw threads.

2. Apply a thick coat of grease to the special screw and the cam surface of the clutch release disc.

IMPORTANT: Make sure belleville washers are installed correctly (Fig. 16).

3. Assemble both belleville washers, clutch release disc, and flange bushing to the driver pulley.
4. Insert special screw through the clutch release disk, driver pulley and compression spring.
5. Apply Loctite 271 or equivalent to the threads of the special screw. Secure compression spring to the special screw with clutch pin. The clutch pin should extend out from 0.240 to 0.260 inch (6.10 to 6.60 mm) the face of the driver pulley when the pin is fully extended (Fig. 16).

Installation

1. Park mower on a level surface. Make sure engine is OFF. Remove high tension lead from the spark plug.
2. If removed, reinstall clutch adapter to the reel shaft (Fig. 15). Torque clutch adapter to 17 ft–lb (2.4 kg–m).
3. Place clutch assembly on the shaft of the clutch drive adapter. Secure flat washer and lock nut the shaft of the clutch drive adapter (Fig. 6).
4. Hold drive belt on the driver pulley and slide clutch onto the clutch adapter shaft while sliding the belt onto the driven pulley (Fig. 14).
5. Secure flat washer to the clutch adapter shaft with the lock nut. Torque lock nut from 120 to 150 in–lb (138 to 173 kg–cm) removing all clutch assembly end play (Fig. 6).
6. Tension drive belt (see Drive Belt Tension in the Adjustments section) and tighten socket head cap screw (Fig. 14).
7. Place belt cover on housing and secure with three socket head cap screws and washers (Fig. 7).
8. Reinstall clutch knob and poly washer to the clutch assembly. Tighten both set screws in the clutch knob (Fig. 6).

Frame Assemblies (RH and LH)

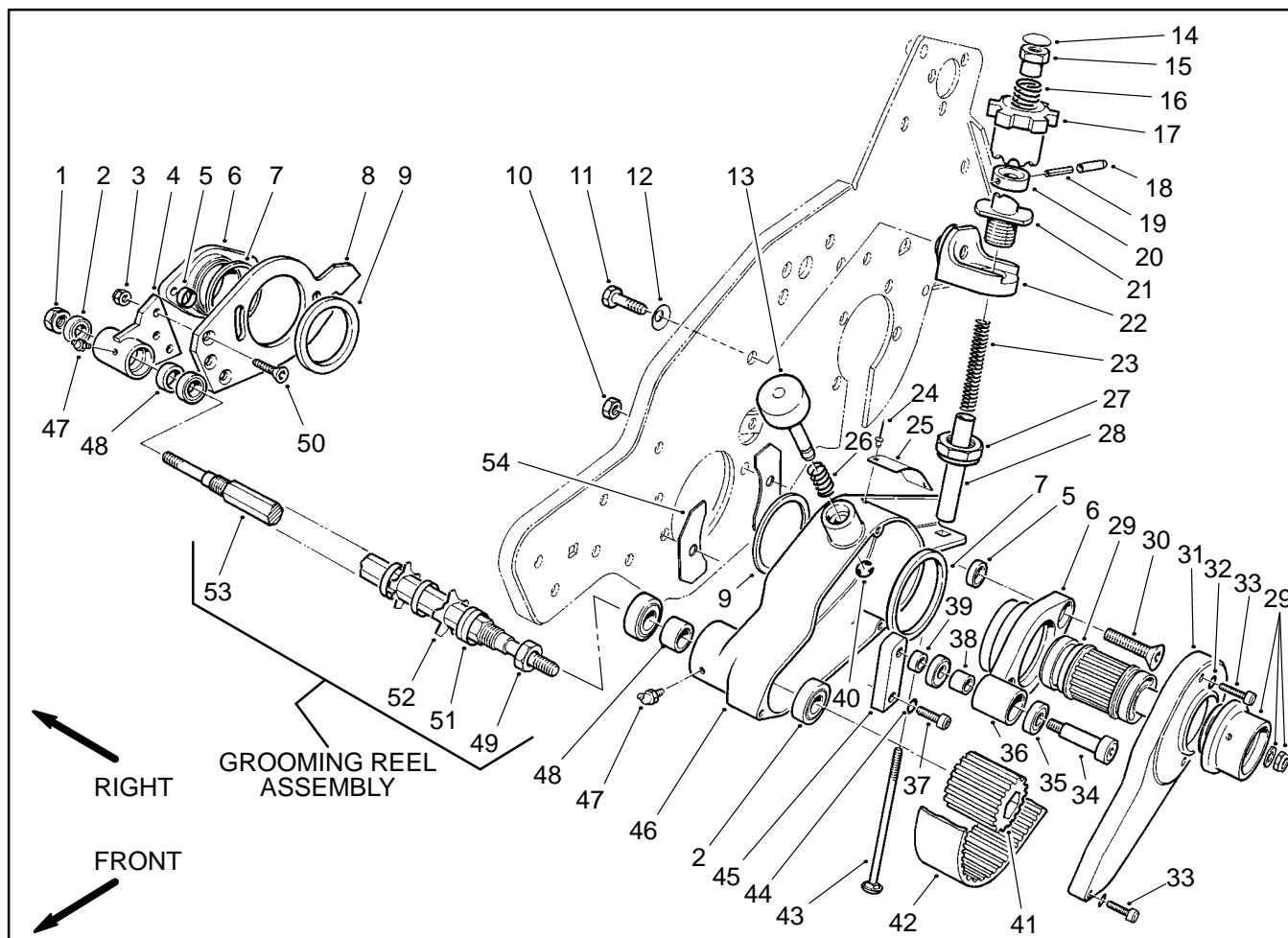

Figure 17

- | | | |
|-----------------------|----------------------------|----------------------------|
| 1. Lock nut | 19. Roll pin | 37. Socket head cap screw |
| 2. Ball bearing | 20. Cap | 38. Idler pulley spacer |
| 3. Lock nut | 21. Ramp | 39. Spacer |
| 4. Bearing housing | 22. Mounting block | 40. Retaining ring |
| 5. Spacer | 23. Spring | 41. Driven pulley |
| 6. Adapter | 24. Pop rivet | 42. Drive belt |
| 7. Bearing | 25. Caution plate | 43. Carriage bolt |
| 8. Side plate | 26. Spring | 44. Lock washer |
| 9. Adapter Ring | 27. Lock nut | 45. Idler block |
| 10. Lock nut | 28. Spring spacer | 46. Belt drive housing |
| 11. Cap screw | 29. Clutch assembly | 47. Grease fitting |
| 12. Belleville washer | 30. Flat head socket screw | 48. Driven pulley spacer |
| 13. Cap | 31. Belt cover | 49. Lock nut |
| 14. Plug | 32. Lock washer | 50. Flat head socket screw |
| 15. Driver | 33. Socket head cap screw | 51. Spacer |
| 16. Spring | 34. Shoulder screw | 52. Blade |
| 17. Adjustment knob | 35. Bearing | 53. Shaft |
| 18. Pin cover | 36. Idler pulley | 54. Slot cover |

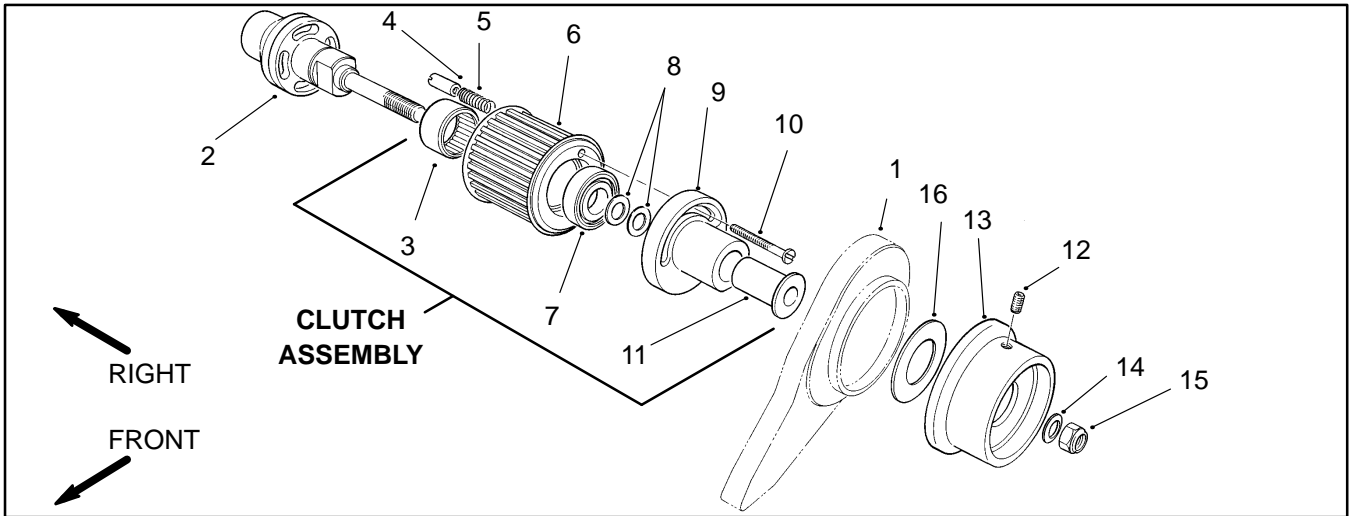

Figure 18

- 1. Belt cover
- 2. Clutch drive adapter
- 3. Needle bearing
- 4. Clutch pin
- 5. Compression spring
- 6. Driver pulley

- 7. Roller bearing
- 8. Belleville washer
- 9. Clutch release disc
- 10. Special screw
- 11. Flange bushing

- 12. Set screw
- 13. Clutch knob
- 14. Flat washer
- 15. Lock nut
- 16. Poly washer

Removal

Note: An older model of the GR 1000 has been used for illustrating purposes. The procedures are the same for both older and newer models except as noted.

1. Make sure engine is OFF. Remove high tension lead from the spark plug. Place mower on a level surface or on a workbench.

2. Remove four cap screws and lock washers and then the reel drive cover (Fig. 19).

3. On newer models, loosen drive belt on the reel drive assembly as follows:

A. Lower grass shield by loosening both cap screws and lock nuts securing the shield to the frame (Fig. 20).

B. Loosen cap screw on clutch housing. Pivot idler pulley counterclockwise (arrow direction) to loosen reel drive belt. Remove reel drive belt (Fig. 21).

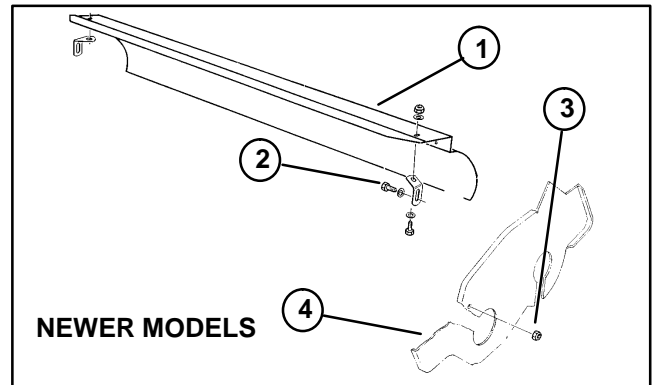

Figure 20

- 1. Grass shield
- 2. Cap screw
- 3. Lock nut
- 4. Frame

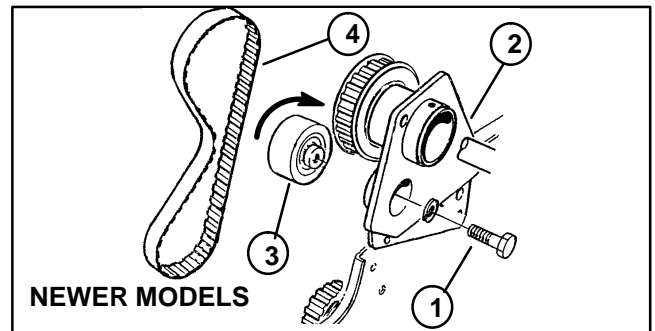

Figure 21

- 1. Cap screw
- 2. Clutch housing
- 3. Idler pulley
- 4. Drive belt

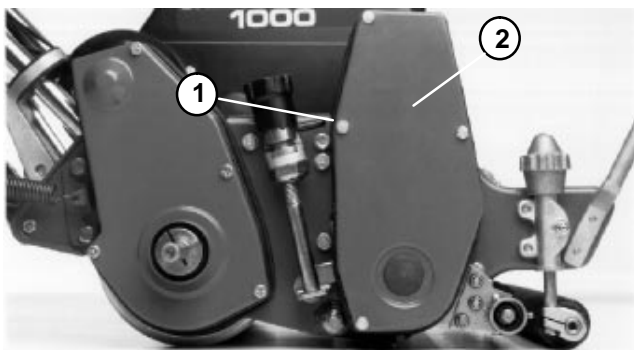

Figure 19

- 1. Cap screw & lock washer
- 2. Reel drive cover

4. On older models, loosen both carriage bolts securing the reel idler bracket to the frame. Pivot idler pulley assembly away from the reel drive belt. (Fig. 22).

5. Secure cutting reel from turning with a block of hard wood. Use a 1/2-inch drive ratchet with an extension to remove the drive pulley and drive belt from the cutting reel shaft (Fig. 22).

6. From the right side of the mower, remove the following (Fig. 17):

A. Remove lock nut (1) securing the shaft (53) to the bearing housing (4).

B. Use allen wrench to remove both flat head screws. Remove groomer arm cover from reel bearing housing (Fig. 22).

C. Remove adapter (6), bearing (7) if necessary, spacers (5), and adapter ring (9) from the side plate (8).

7. On both sides of the mower (Fig. 23),

A. Use spring compressor or clamp to compress springs in bedbar adjuster frames to free the bedbar adjuster from the bedbar ear.

B. Remove both cap screws and washers securing the bedbar adjuster frame to the mower frame.

C. Remove cap screw (11) and belleville washer (12) (inside of frame) securing mounting block (22) to the mower frame (Fig. 17).

8. Loosen both set screws on the clutch knob. Remove the clutch knob and the poly washer behind it from the clutch assembly (Fig. 18).

9. Remove the three socket head cap screws (33) and lock washers (32). Remove belt cover (31) from the belt drive housing (46) (Fig. 17).

10. In the belt drive housing (46), disassemble the following parts (Fig. 17):

A. Loosen socket head cap screw (37) and idler pulley (36), then remove drive belt (42) from the driven pulley (41).

Note: The driven pulley (42) has **left handed** threads.

B. Use an allen wrench to remove driven pulley from the shaft (53).

11. Remove lock nut and flat washer from the shaft of the clutch drive adapter. Pull clutch assembly off the shaft of the clutch drive adapter (Fig. 18).

12. Secure cutting reel from turning with a block of hard wood. Remove clutch adapter from reel shaft (Fig. 24).

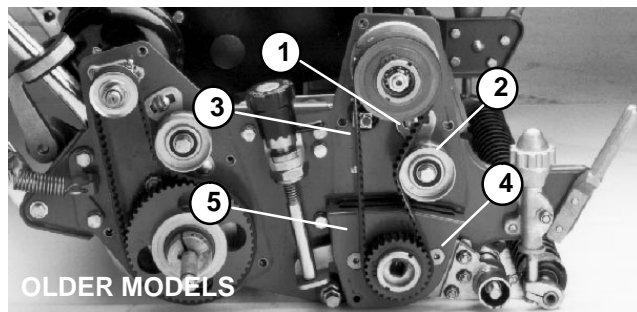

Figure 22

- | | |
|--------------------------|----------------------|
| 1. Reel idler bracket | 4. Flat head screw |
| 2. Idler pulley assembly | 5. Groomer arm cover |
| 3. Reel drive belt | |

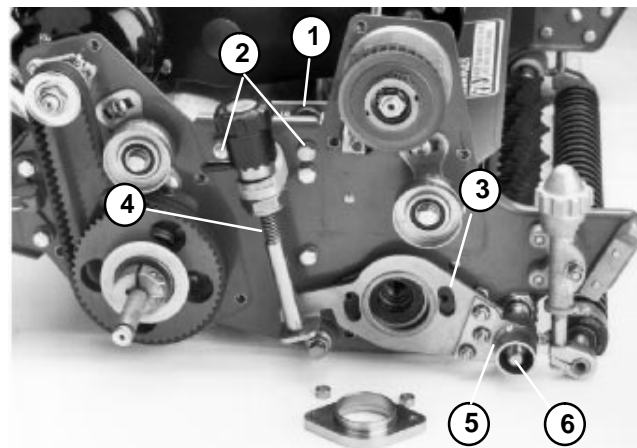

Figure 23

- | | |
|--------------------------|------------------------|
| 1. Bedbar adjuster frame | 4. Groomer adjuster |
| 2. Cap screw and washer | 5. Bearing housing |
| 3. Side plate | 6. Grooming reel shaft |

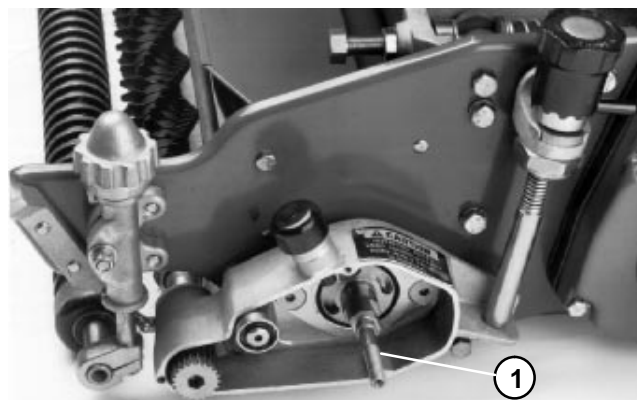

Figure 24

- | | |
|---------------------------|------------|
| 1. Clutch adapter | 3. Adapter |
| 2. Flat head socket screw | |

13. Pull side plate with the groomer adjuster and bearing housing from the grooming reel shaft and reel bearing housing (Fig. 23).

14. Remove grooming reel from the belt drive housing (46) (Fig. 17).

15. Use allen wrench to remove flat head socket screws from the adapter (Fig. 25).

16. Remove adapter (6), bearing (7), both spacers (5) from the belt drive housing (46) (Fig. 17).

17. Pull belt drive housing with the groomer adjuster from the reel bearing housing (Fig. 25).

18. Remove adapter ring (9) and both slot covers (54) from the reel bearing housing (Fig. 17).

19. If removing the cutting reel, see Cutting Reel Removal in this section..

Installation

1. Park mower on a level surface. Make sure engine is OFF. Remove high tension lead from the spark plug.

2. If bedbar adjuster frames have not been removed, remove the following on both sides of the mower frame (Fig. 25):

A. Use spring compressor or clamp to compress springs in bedbar adjuster frames to free the bedbar adjuster from the bedbar ear.

B. Remove both cap screws and washers securing the bedbar adjuster frame to the mower frame.

3. Install frame assembly (LH) to the left side of the mower frame (Fig. 25 and 26).

A. If removed, press new bearing into belt drive housing.

B. Insert adapter ring into the reel bearing housing.

C. Insert both flat head socket screws through the adapter. Position spacers on the screws.

D. Align adapter, spacers, and flat head socket screws with the slots in the belt drive housing. Slide adapter through the bearing, then slide the screws through the slots in the housing.

E. Insert a slot cover onto each flat head socket screw while aligning the curved side of the cover with the curve of the belt drive cover. Covers should curve away from the housing.

Note: It may be necessary to move or remove the bedbar to gain access to the lock nuts.

F. Slide flat head socket screws through the reel bearing housing. Screw lock nuts on both screws. Torque screws from 23 to 27 ft-lb (3.2 to 3.7 kg-m).

Note: The driven pulley (42) has **left handed** threads.

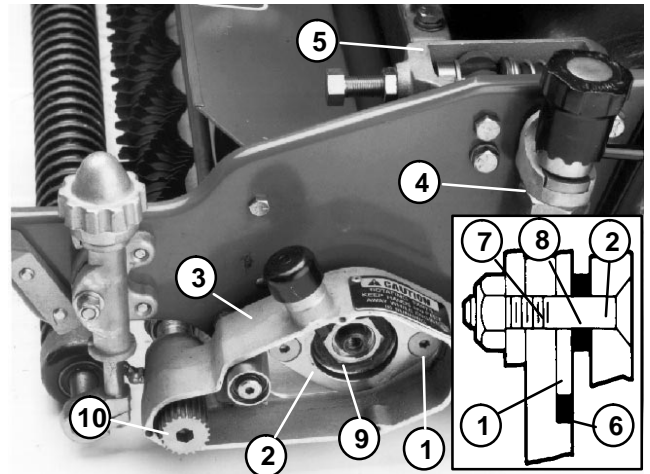

Figure 25

- | | |
|---------------------------|-----------------------------|
| 1. Flat head socket screw | 6. Adapter ring |
| 2. Adapter | 7. Reel bearing housing |
| 3. Belt drive housing | 8. Spacer |
| 4. Groomer adjuster | 9. Reel bearing lock nut |
| 5. Bedbar adjuster frame | 10. Driven pulley (removed) |

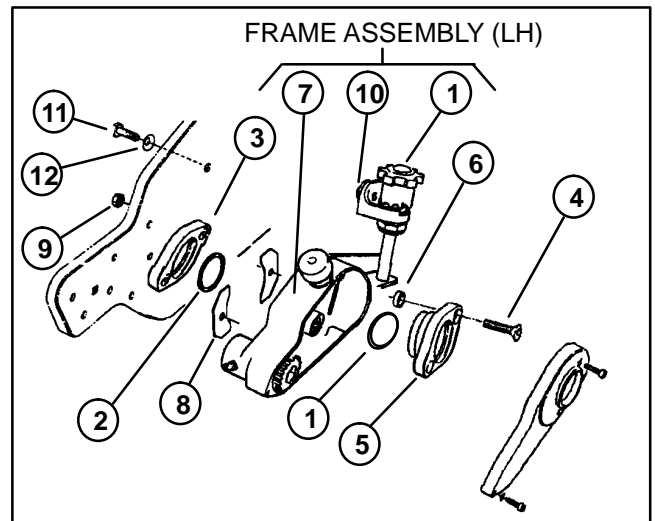

Figure 26

- | | |
|----------------------------|-----------------------|
| 1. Bearing | 7. Belt drive housing |
| 2. Adapter ring | 8. Slot cover |
| 3. Reel bearing housing | 9. Lock nuts |
| 4. Flat head socket screws | 10. Mounting block |
| 5. Adapter | 11. Cap screw |
| 6. Spacers | 12. Belleville washer |

4. Place one end of shaft (53) into the bearing support of the belt drive housing (46). Mount driven pulley (41) to the shaft. Torque pulley from 29 to 35 ft-lb (4.0 to 4.8 kg-m) using a 3/8-inch allen socket on the torque wrench (Fig. 17).

5. Secure mounting block to the frame with cap screw and belleville washer (Fig. 26).

6. Reinstall bedbar adjuster frame to mower frame with cap screws and washers previously removed (Fig. 25).

7. Install frame assembly (RH) onto the right reel bearing housing using the following procedure (Fig. 27):

A. Slide bearing housing of frame assembly (RH) over the end of the grooming reel shaft (Fig. 28)

B. Insert adapter ring (9) into the reel bearing housing (Fig 17).

C. Insert both flat head screws through the groomer arm cover and adapter. Put a spacer over each screw before placing the adapter into the reel bearing housing (Fig. 28 and 29).

D. Slide adapter through the bearing and into the reel bearing housing. Install lock nuts on flat head screws and torque from 23 to 27 ft-lb (3.2 to 3.7 kg-m) (Fig. 28 and 29).

Note: The lock nut (1) has **left handed** threads.

E. Secure the grooming reel shaft (53) to the bearing housing (4) with lock nut (1). Torque lock nut from 29 to 35 ft-lb (4.0 to 4.8 kg-m) (Fig 17).

8. Secure mounting block (22) to the frame with cap screw (11) and belleville washer (12) (Fig. 17 and 29).

9. Reinstall bedbar adjuster frame to the mower frame with cap screws and washers previously removed (Fig. 28).

IMPORTANT: If the clutch assembly was disassembled, make sure it is reassembled properly (see Clutch Assembly Reassembly).

10. Complete the reinstallation of the clutch assembly and belt drive housing by following the instructions in **Clutch Assembly Reinstallation** (Fig. 30).

11. Use a 1/2-inch drive ratchet and extension to reinstall drive pulley and reel drive belt to cutting reel shaft. Torque drive pulley from 40 to 60 ft-lb (5.5 to 8.3 kg-m) (Fig. 29).

12. On newer models, tighten reel drive belt as follows:

A. Pivot idler pulley clockwise (opposite arrow direction) to tighten reel drive belt. Tighten belt from 20 to 25 lb (89 to 111 N) of force. Tighten cap screw on clutch housing. (Fig. 21).

B. Raise grass shield to 4 inches from the top of the support rod. Tighten both cap screws and lock nuts securing the shield to the frame (Fig. 20).

13. On older model, pivot idler pulley assembly against the reel drive belt. Apply 20 to 25 lb (89 to 111 N) of force to the idler pulley. Tighten both carriage bolts securing the reel idler bracket to the frame (Fig. 29).

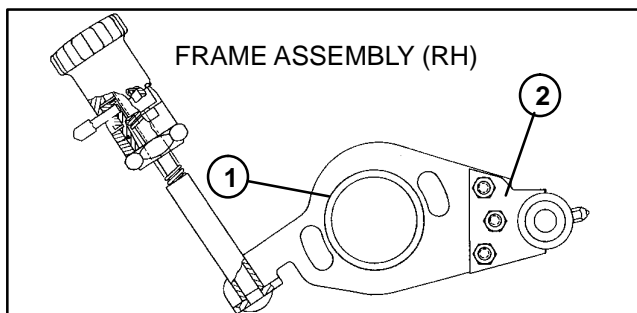

Figure 27

- 1. Bearing
- 2. Bearing housing

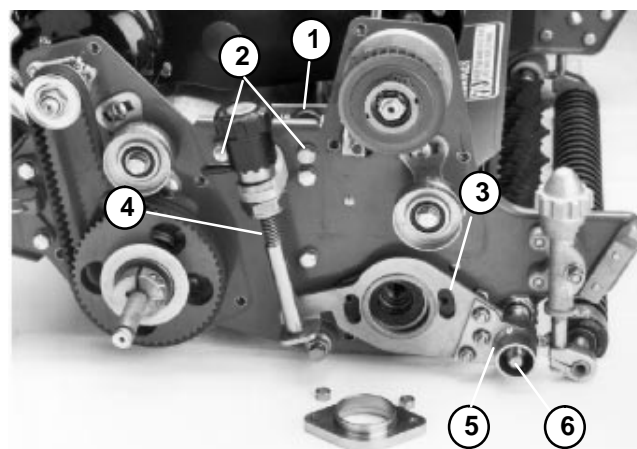

Figure 28

- 1. Bedbar adjuster frame
- 2. Cap screw and washer
- 3. Side plate
- 4. Groomer adjuster
- 5. Bearing housing
- 6. Grooming reel shaft

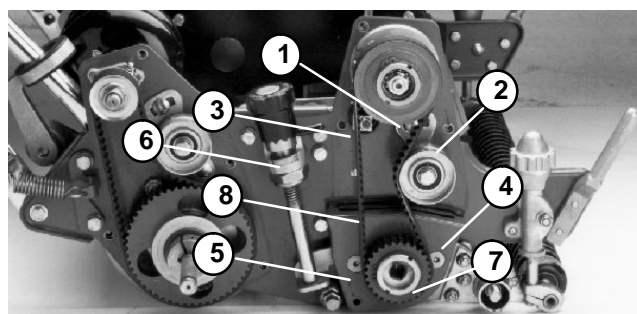

Figure 29

- 1. Reel idler bracket
- 2. Idler pulley assembly
- 3. Reel drive belt
- 4. Flat head screw
- 5. Groomer arm cover
- 6. Mounting block
- 7. Drive pulley
- 8. Reel drive belt

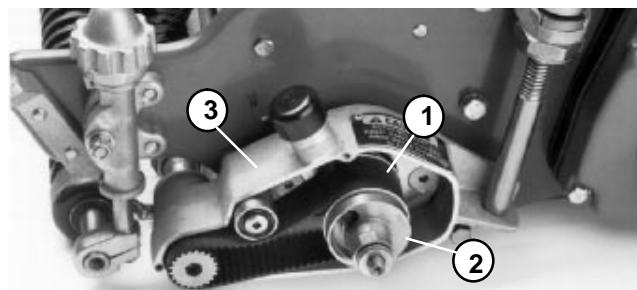

Figure 30

- 1. Drive belt
- 2. Driven pulley
- 3. Clutch drive housing

14. Check groomer assembly (Fig. 31).

A. Rotate both quick-up levers to raise the grooming reel into the transport position.

B. Hold the clutch snubber down and rotate the clutch knob clockwise to disengage the clutch.

C. Correct any problems and recheck assembly.

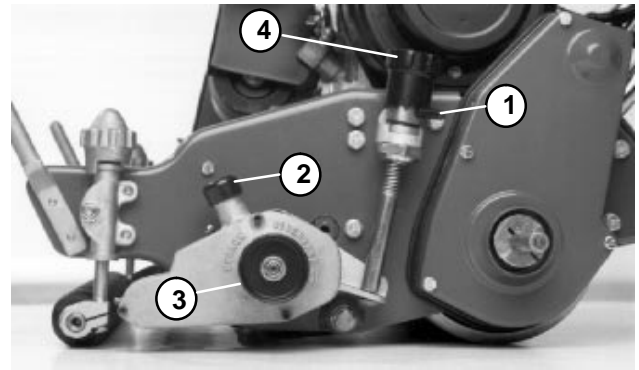

Figure 31

- | | |
|-------------------|--------------------------|
| 1. Quick-up lever | 3. Clutch knob |
| 2. Clutch snubber | 4. Micro adjustment knob |

Cutting Reel

Removal

1. Park mower on a level surface. Make sure engine is OFF. Remove high tension lead from the spark plug.
2. Make sure mower is on a flat level surface or on a stable work bench.
3. Remove grooming reel kit following the Removal instructions in Frame Assemblies (RH and LH).
4. Remove bedbar from the mower (see Bedbar Removal in Service and Repairs section of Chapter 7 – Cutting Unit).
5. Remove grease fittings from both bearing housings. Mark bearing housing (RH) for reassembly purposes (Fig. 32 and 33).
6. Secure cutting reel from turning with a block of hard wood, and remove lock nut from the cutting reel shaft (Fig. 33).
7. Pull both bearing housings from the frame and reel (Fig. 32 and 33). Remove the reel from the mower.
8. If bearings are worn or need replacement for maintenance purposes, remove bearings from **both** bearing housings as follows:
 - A. Remove bearing seal, retaining ring, bearing, and wave washer from the bearing housing (RH). Discard wave washer (Fig. 32).
 - B. Remove large seal, small seal, and bearing from the bearing housing (LH) (Fig. 33).

Installation

1. Make sure engine is OFF. Remove high tension lead from the spark plug. Place mower on a flat level surface or on a stable work bench.

IMPORTANT: Make sure correct bearing housing is used when installing bearings. The grease fitting hole should face forward when the housing is placed in the frame.

2. Reassemble bearing housing (RH) components (Fig. 32).

IMPORTANT: Make sure the correct bearing housing is used when installing bearings. The grease fitting hole should face forward when the housing is placed in the frame.

- A. Bearing housing (RH) should be marked from disassembly.

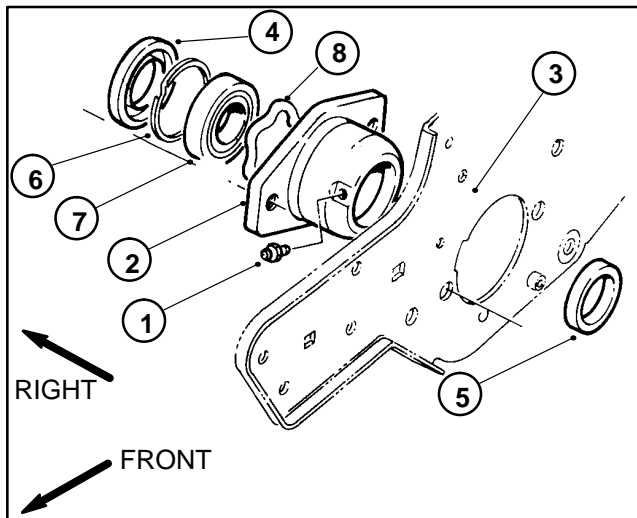

Figure 32

- | | |
|-------------------------|-------------------|
| 1. Grease fitting | 5. Small seal |
| 2. Bearing housing (RH) | 6. Retaining ring |
| 3. Frame | 7. Bearing |
| 4. Large seal | 8. Wave washer |

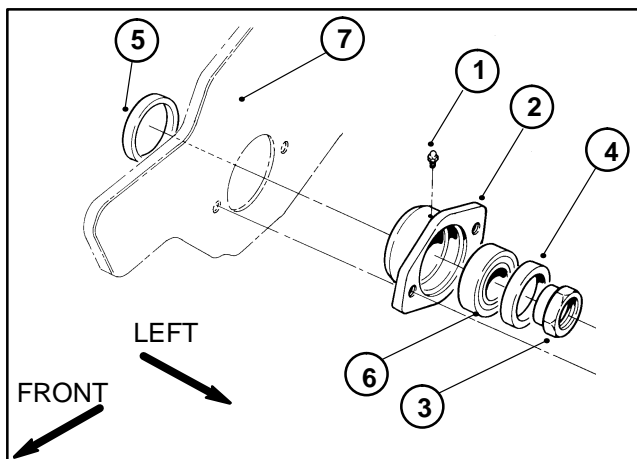

Figure 33

- | | |
|-------------------------|---------------|
| 1. Grease fitting | 5. Small seal |
| 2. Bearing housing (LH) | 6. Bearing |
| 3. Bearing lock nut | 7. Frame |
| 4. Large seal | |

- B. Place small seal into the bearing housing with the flat side out.

- C. Place **new** wave washer into bearing housing. Press **new** bearing into the bearing housing with a bearing driver.

- D. Install and seat retaining ring into the groove of the housing.

- E. Place large seal on the bearing housing with the flat side out. Press seal in with a seal driver.

3. Reassemble bearing housing (LH) components (Fig. 33).
 - A. Place small seal into the bearing housing with the flat side out.
 - B. Press **new** bearing into the bearing housing with a bearing driver.
 - C. Place large seal on the bearing housing with the flat side out. Press seal in with a seal driver.
4. Position reel in frame to accept bearing housings. The reel shaft end with internal threads should be on the right side of the frame.

Note: The two bearing housings are similar in appearance but can not be interchanged. The bearing housing (RH) was marked prior to removal.
5. Attach bearing housing (RH) through the frame onto the reel shaft (Fig. 32).
 - A. Push housing onto reel shaft. If necessary, tap into position with a soft hammer.
 - B. Make sure grease fitting hole is positioned to the front of the mower.
6. Attach bearing housing (LH) through the frame onto the reel shaft (Fig. 33).
 - A. Push housing onto reel shaft. If necessary, tap into position with a soft hammer.
 - B. Make sure grease fitting hole is positioned to the front of the mower.
7. Secure cutting reel from turning with a block of hard wood. Tighten lock nut to the cutting reel shaft (Fig. 33). Torque lock nut to 50 ft–lb (6.9 kg–m).
8. Reinstall grease fittings to both bearing housings. Lubricate both housings with No. 2 multipurpose lithium base grease (Fig. 32 and 33).
9. Reinstall bedbar to the mower (see Bedbar Installation in the Service and Repairs section of Chapter 7 – Cutting Unit).
10. Reinstall grooming reel kit following the Installation instructions in Frame Assemblies (RH and LH).

Lubrication

There are two grooming reel shaft bearings on each end of the mower.

1. Park mower on a level surface. Make sure engine is OFF. Remove high tension lead from the spark plug.
2. Use a hand pump grease gun and No. 2 multipurpose lithium base grease for lubrication.
3. Pump only a maximum of 2 to 3 pumps of grease to avoid permanently damaging the grease seals.



Figure 34



Commercial Products